

Phasor XS

User's Manual



GE
Measurement & Control Solutions

Phasor XS

Portable Phased Array Ultrasonic Flaw Detector

User's Manual

021-002-362 Rev. 10
August 2010



GESensingInspection.com

©2010 General Electric Company. All rights reserved.
Technical content subject to change without notice.

[no content intended for this page - proceed to next page]

Important Notice

General Warnings vii

Operator Training vii

Testing Limitations vii

Ultrasonic Measurement Critical Operating Procedures viii

Safety Information ix

 Software ix

 Defects/errors and Exceptional Stresses ix

Service x

Chapter 1. Phased Array Operation—Keypad, Menus, and Displays

1.1 Supplying Power 1

1.2 Powering the Instrument On and Off 2

1.3 Keypad and Knob Features 3

1.4 Home Menu and Functions 4

1.5 Display Screen Features (Phased Array) 13

1.6 Startup Mode 14

1.7 Software Updates 15

 1.7.1 Phasor XS Software Upgrade Procedures 15

 1.7.2 Phasor XS Upload Code Upgrade Procedure 15

Chapter 2. Setting Up for Phased Array Measurement

2.1 Language, Units of Measurement, Date, and Time18

2.2 Display Appearance20

2.3 Installing a Phased Array Probe22

 2.3.1 Connecting a Probe22

 2.3.2 Configuring the Instrument for a Phased Array Probe23

 2.3.3 Inputting Wedge-Related Information.....24

2.4 Inputting Test-Piece Properties.....29

2.5 Defining the Scan Parameters.....30

2.6 Defining the Ultrasonic Characteristics of the Displayed Scan33

 2.6.1 LEG Setting to Control the Scan Range33

 2.6.2 Setting the Display Delay33

 2.6.3 Defining the Display’s Starting Point34

 2.6.4 Setting the Encoder Direction (SCAN-SYNCH-ENC COUNT DIR)35

2.7 Pulser and Receiver Settings for Phased Array Operation.....36

 2.7.1 Setting the Pulser Voltage Level (UT-PULSER-VOLTAGE)36

 2.7.2 Selecting the Pulser Width (UT-PULSER-WIDTH).....36

 2.7.3 Specifying the Receiver Frequency (UT-RECEIVER-FREQUENCY)37

 2.7.4 Selecting a Rectification Mode (UT-RECEIVER-ASCAN RECTIFY)37

2.8 Managing Gates for Phased Array Operation.....39

 2.8.1 Positioning Gates.....39

 2.8.2 Selecting the TOF-Detection Method41

 2.8.3 Setting Gate Logic.....41

 2.8.4 Configure the Gate to Ignore or Accept Off-Screen Triggers (DISPLAYRESULTS2-GATE SHAPE) .42

 2.8.5 Assign TTL Output / Alarm Indication Light to a Gate (DISPLAY-RESULTS2-TTL #1)43

2.9 Calibrating the Instrument/Probe Combination43

 2.9.1 Performing a Quick Calibration44

 2.9.1 Depth Cal.....46

 2.9.1a Auto-Zero After Finish48

2.10 Optional Graphic Overlay49

Chapter 3. Operating in Phased Array Mode

3.1	Selecting the Displayed View (Phased Array)	53
3.2	Displaying Results (Phased Array)	53
3.3	Controlling A-Scan Orientation and Beam Cursor Position	62
3.4	Operating in Freeze Mode (Phased Array)	63
3.5	Tip Diffraction Sizing Technique in A-Scan	65
3.6	Setting the Gain (Phased Array)	66
3.7	Operating in TCG Mode (Phased Array)	68
3.7.1	Recording the TCG Reference Points	68
3.7.2	Selecting Beam-Groups of Interest During the TCG Recording Process	71
3.7.3	Applying Incremental Gain to Beam Groups During the Recording Process	71
3.7.4	Manually Imputing TCG Points	73
3.7.5	Editing TCG Points	74

Chapter 4. Conventional Operation: Menu System, Keypad, and Displays

4.1	Supplying Power	78
4.2	Powering On and Off the Instrument	79
4.3	Keypad and Knob Features	79
4.4	Home Menu, Eval Menus, and Functions	82
4.5	Display Screen Features (Conventional)	92
4.6	Initial Instrument Setup	92
4.6.1	Language, Units of Measurement, Date, and Time	93
4.6.2	Display Appearance	95
4.7	Installing a Conventional Probe	97
4.7.1	Connecting a Conventional Probe	97
4.7.2	Configuring the Instrument to Match the Probe Type	97
4.7.3	Adjusting the Pulser Repetition Frequency (PRF)	99
4.7.4	Selecting a Rectification Mode	100
4.7.5	Setting the Pulser Voltage or Energy Level	101
4.7.6	Setting the A-Scan REJECT Level	101
4.8	Adjusting the A-Scan (Conventional)	102
4.8.1	Setting the A-Scan Range	102
4.8.2	Setting the Display Delay	102
4.9	Calibrating the Instrument	103
4.9.1	Pre-calibration Check List	103
4.9.2	Using AUTOCAL to Calibrate the Instrument	104
4.10	Using the Calibration Reminder Alarm	104
4.11	Activating Instrument Upgrades	105

Chapter 5. Making Conventional Measurements

5.1	Configuring the A and B-Gates	108
5.1.1	Positioning Gates	108
5.1.2	Selecting the TOF-Detection Method	110
5.1.3	Setting Gate Alarms and Outputs	111
5.2	Using Angle Beam Probes and the TRIG Menu	112
5.2.1	Setting Angle Beam Probe Characteristics	113
5.2.2	Indicating Leg with Color	113
5.3	Displaying Measured Results	114
5.4	Saving the Instrument Configuration in a Data Set	116
5.5	Locking the Gain Rotary Knob	116
5.6	Setting the Gain	117
5.6.1	Changing the Gain-Adjustment Increment (dB STEP)	117
5.6.2	Setting the User-Defined Gain Step (SETUP-GAIN-USER GAIN STEP)	117
5.7	Freezing the A-Scan Display	117
5.8	DAC/TCG Evaluation Mode	118
5.9	Using DAC	119
5.9.1	Recording the DAC Curve	119
5.9.2	Working with DAC	120
5.10	Using TCG	121
5.10.1	Generating the TCG Reference Curve	121
5.10.2	Working with TCG	122
5.11	Adjusting DAC or TCG Display and Adding Offsets	123
5.12	Editing and Deleting DAC and TCG Reference Points	123
5.13	Deleting a DAC Curve or TCG Reference Points	124
5.14	DGS Evaluation Mode	124
5.14.1	Specifying a Probe and Preparing to Record the Reference Echo	125
5.14.2	Record the Reference Echo that Defines the DGS Curve	126
5.14.3	Display and Adjust the DGS Curve	128
5.14.4	Evaluating Results in DGS Mode	129
5.14.5	Locks, Error Messages	129
5.14.6	Validity of the DGS Method	129
5.15	dB REF Evaluation Mode	130
5.16	AWS D1.1 Weld Rating Evaluation Mode	131
5.17	JISDAC Evaluation Mode	133
5.17.1	Recording the JISDAC Curve	133
5.17.2	Working with DAC	134
5.17.3	Deleting a JISDAC Curve	135

Chapter 6. Storing Data Sets and Generating Reports

6.1 Data Set Files 137

 6.1.1 Creating Data Set Files 138

 6.1.2 Editing Active Files 139

6.2 Recalling Existing Data Sets 140

6.3 Deleting (CLEARING) Existing Data Sets 141

6.4 Creating a Memo 141

6.5 Creating a Report Header. 142

6.6 Generating a Report. 142

Chapter 7. Working in TOP View (Optional Feature)

7.1 Preparing for TOP View Operation 145

 7.1.1 Setting Up the Phased Array Prior to Displaying a TOP View 146

 7.1.2 Setting Up TOP View for TIMED, or TIMED CONTINUOUS Operation. 147

 7.1.3 Setting Up TOP View for ENCODED Operation. 149

 7.1.4 Encoder Calibration 150

7.2 Creating a TOP View 151

7.3 Freezing the Display and Navigating Data in TOP View 157

7.4 Storing the TOP View Data 162

7.5 Using TOP View’s ENCODED Mode – User Application Summary. 163

Chapter 8. Making Custom Corrosion Measurements

8.1 Doubling. 165

8.2 Calibrating a Custom Instrument/Probe Combination. 165

8.3 Two-Point Calibration for Probe Zero and Material Velocity 167

 8.3.1 2-POINT D-CAL 167

 8.3.2 1-POINT D-CAL (Probe Delay or Probe Zero) 170

8.4 Saving the Data to a Microsoft Excel™ File 172

 8.4.1 Procedure 172

 8.4.2 Setup 172

 8.4.3 Storing A Log File 172

Chapter 9. DGS in Phased Array Mode

9.1 Setting Up DGS Evaluation 175

9.2 Dialog Probe Settings and POP Setup File 176

9.3 DGS Curve Interpolation 177

9.4 Gain Control and Display 179

9.5 Parameter Limit/Block. 180

9.6 DGS Evaluation Menus 182

 9.6.1 DGS Top Level Menu. 182

 9.6.1a DGS Setup Menu. 182

9.6.1b DGS Gate A Menu	183
9.6.1c DGS Reference Echo Menu	183
9.6.2 DGS Reference Correction Menu	186
9.6.2a Reference Attenuation	186
9.6.2b Amplitude Correction	186
9.6.3 DGS Material Attenuation Menu	187
9.7 DGS Icon	188
9.8 PA Results	188
9.9 JPEG Reports	188
9.10 Validation	189
9.11 Data Storage and Recall	189
Appendix A. Technical Specifications	
A.1 Physical Specifications	191
A.2 Phased Array/Conventional Channel Specifications	192
A.3 Environmental Tests	193
A.4 Phased Array Probes	194
A.5 RS-232 Serial Port Connector	194
A.6 SAP/TTL Output Connector	196
Environmental Compliance	203
Warranty	205
Return Policy	205

Important Notice

The following information must be read and understood by any user of a GE Inspection Technologies ultrasonic thickness gauge. Failure to follow these instructions can lead to errors in thickness measurements or other test results. Decisions based on erroneous results can, in turn, lead to property damage, personal injury or death.

General Warnings

Proper use of ultrasonic test equipment requires three essential elements:

- Selection of the correct test equipment.
- Knowledge of the specific “test application requirements.”
- Training on the part of the instrument operator.

This operating manual provides instruction in the basic set up and operation of the Phasor CV/DM. There are, however, additional factors which affect the use of ultrasonic test equipment. Specific information regarding these additional factors is beyond the scope of this manual. The operator should refer to textbooks on the subject of ultrasonic testing for more detailed information.

Operator Training

Operators must receive adequate training before using ultrasonic test equipment. Operators must be trained in general ultrasonic testing procedures and in the set up and performance required by a particular test. Operators must understand:

- Soundwave propagation theory.
- Effects of the velocity of sound of the test material.
- Behavior of the sound wave where two different materials are in contact.
- Areas covered by the sound beam.

More specific information about operator training, qualification, certification, and test specifications is available from various technical societies, industry groups, and government agencies.

Testing Limitations

In ultrasonic testing, information is obtained only from within the limits of the sound beam. Operators must exercise great caution in making inferences about the test material outside the limits of the sound beam. For example, when testing large materials, it may be impossible or impractical to inspect the entire test piece.

When a less-than-complete inspection is to be performed, the operator must be shown the specific areas to inspect. Inferences about the condition of areas not inspected, based on data from the evaluated areas, should only be attempted by personnel fully trained in applicable statistical and probability techniques. In particular, materials subject to erosion or corrosion, in which conditions can vary significantly in any given area, should only be evaluated by fully trained and experienced operators. Sound beams reflect from the first interior surface encountered. Because of part geometry and overlapped flaws or overlapped surfaces, thickness gauges may measure the distance to an internal flaw rather than to the back wall of the material. Operators must take steps to ensure that the entire thickness of the test material is being examined.

Ultrasonic Measurement Critical Operating Procedures

The following operating procedures must be observed by all users of ultrasonic instruments in order to minimize errors in test results.

1. *Calibration of Sound Velocity*

The principle of operation of the Phasor XS is that the instrument measures the time of flight of an ultrasonic pulse through the test piece and multiplies this time by the velocity of sound in the material. Measuring error is minimized by ensuring that the sound velocity to which the instrument is calibrated is the sound velocity of the material being tested. Actual sound velocities in materials often vary significantly from the values found in published tables. In all cases, best results are obtained if the instrument is calibrated on a velocity reference block made from the same material as the test piece; this block should be flat and smooth and as thick as the maximum thickness of the test piece.

Operators should also be aware that the sound velocity may not be constant in the material being tested; heat treating, for example, can cause significant changes in sound velocity. This must be considered when evaluating the accuracy of the thickness provided by this instrument. Instruments should always be calibrated before testing, and the calibration should be checked after testing, to minimize testing errors.

2. *Probe Calibration*

Failure to properly perform the probe zero procedure will cause inaccurate readings.

3. *Effects of Temperature on Calibration*

Temperature variations change the sound velocity of materials and transducer delay lines and, therefore, calibrations. All calibrations should be performed onsite, and with test blocks at the same temperature as the test piece, to minimize errors due to temperature variations.

4. *Transducer Selection*

The transducer used in testing must be in good condition without noticeable wear of the front surface. Badly worn transducers will have a reduced effective measuring range. The specified range of the transducer must include the complete range of thicknesses to be tested. The temperature of the material to be tested must be within the transducer's temperature range.

5. *Use of Couplants*

Operators must be familiar with the use of ultrasonic couplants. Testing skills must be developed so that couplant is used and applied in a consistent manner to minimize variations in couplant layer thickness and errors in test results. Calibration and actual testing should be performed under similar coupling conditions, using a minimum amount of couplant and applying consistent pressure on the transducer.

1.0 Ultrasonic Measurement Critical Operating Procedures (cont.)

6. *Doubling*

Ultrasonic instruments will, under certain conditions, display readings which are twice (or, in some cases, three times) the actual material thickness being measured. This effect, commonly known as “doubling,” can occur below the minimum specified range of the transducer. If the transducer being used is worn, doubling is possible at a thickness greater than the minimum of the specified range.

When using a new transducer, any reading which is less than twice the minimum specified range of the transducer may be a “doubled” reading, and the thickness of the material being tested should be verified by the use of other methods. If the transducer shows any sign of wear, doubling may occur at a second echo or other echo signal combinations may produce a readable signal. The instrument reading and apparent thickness are up to about twice the actual value, resulting in a thickness greater than twice the minimum of the specified range. This thickness should be determined by calibrating the instrument/transducer combination on reference blocks that represent the complete range of possible thicknesses that may be encountered in testing. This is particularly important when the test piece is being ultrasonically measured for the first time or in any case where the history of thickness of the test specimen is unknown.

Safety Information

ATTENTION! The Phasor XS is an instrument for materials testing. Any use for medical applications or other purposes is not allowed.

The Phasor XS may only be used in industrial environments.

The Phasor XS can be operated with batteries or while plugged into an electrical outlet using the AC charger. The power supply unit has the electrical safety class II.

Software

According to the current state of the art, software is never completely free from errors. Before using any software-controlled test equipment, please make sure that the required functions operate perfectly in the intended combination.

Defects/errors and Exceptional Stresses

If you have reason to believe that a safe operation of your instrument is no longer possible, you have to disconnect the instrument and secure it against unintentional reconnection. Remove the batteries if necessary.

A safe operation is no longer possible if:

- The instrument shows visible damages.
- The instrument no longer operates perfectly.
- After prolonged storage under adverse conditions like exceptional temperatures and/or especially high air humidity, or corrosive environmental conditions.
- Being subjected to heavy stresses during transportation

Service

Every effort has been made to provide you with a reliable product. However, should service become necessary, GE Inspection Technologies, has established a number of Factory Trained Service Centers. For the location of the nearest facility, refer to the rear cover of this manual.

Chapter 1. Phased Array Operation—Keypad, Menus, and Displays

The PHASOR XS ultrasonic flaw detection and thickness measurement instrument operates in either phased array or conventional ultrasonic mode. It is capable of storing images and operating parameters in Data Sets and outputting reports (including A-scans, Linear, or Sector Scans) to an SD card. This chapter will help you become more familiar with the menus and functions of the instrument. Closely review the material in this chapter to make better use of the more detailed information found throughout the rest of this manual.

After reviewing this chapter, you'll be able to:

- Supply power to the instrument (Section 1.1)
- Power up the instrument (Section 1.2)
- Understand the function of each key on the keypad (Section 1.3)
- Access each function using the built-in menu system (Section 1.4)
- Interpret the symbols that most often appear on the display (Section 1.5)

1.1 Supplying Power

The instrument operates on a Lithium battery pack located in the rear of its housing, or by using the power adapter (Figure 1 below). To remove the battery compartment cover, first remove the four thumb-screws. The standard Lithium battery pack will provide maximum operating life between charging.

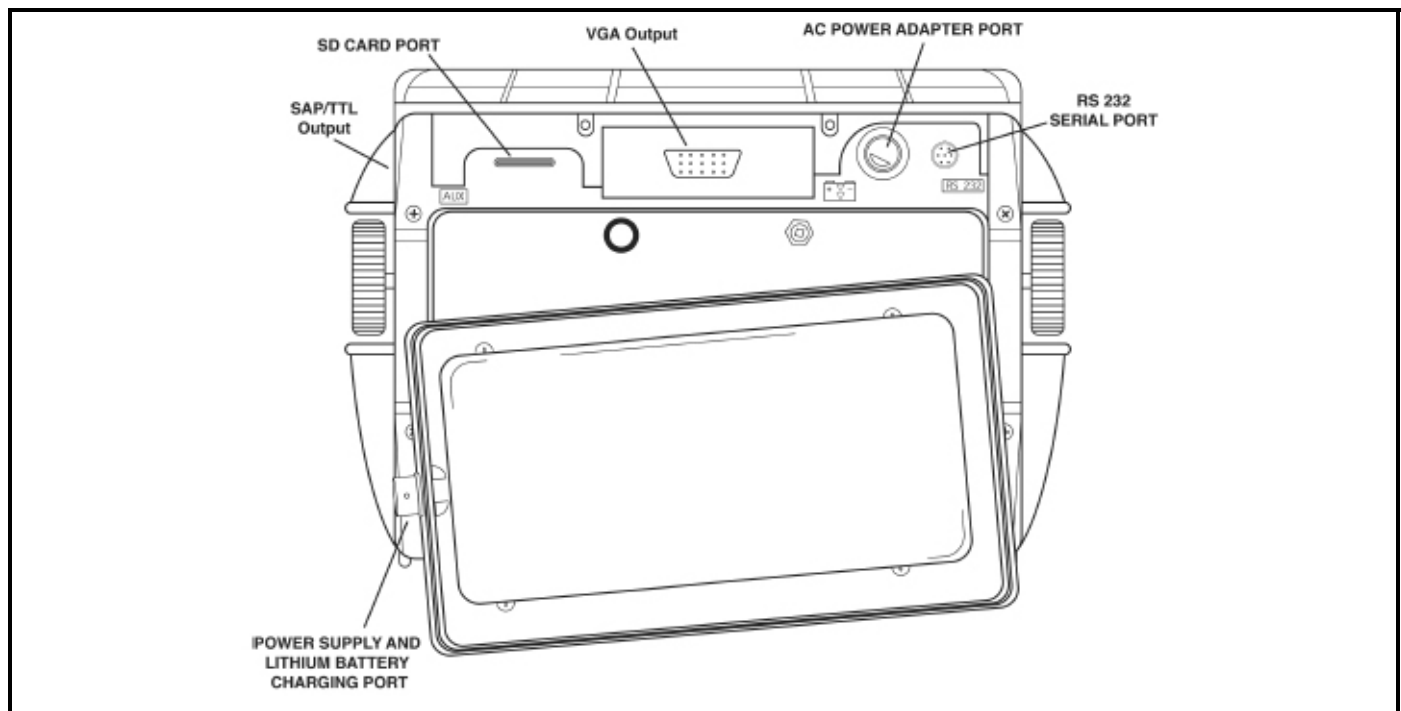



Figure 1: Installation of standard Lithium battery pack. Note the location of the Power Adapter Port and Lithium battery pack on-board charging port.

1.1 Supplying Power (cont.)

Note: Only the dedicated GE Lithium battery pack should be used. Only this pack can be charged while installed in the instrument.

The approximate level of remaining battery life is visually displayed by the . The location of this icon is shown in Figure 1 on the previous page. When a fully charged battery pack is installed, the icon will appear as “full.” As the battery life is consumed, the icon will begin to “empty.”

Note: To ensure that the battery pack is fully recharged, the battery charger must be attached to the battery pack before it is plugged into an AC power source.

Note: When the battery indicator is in the last quarter as indicated by the symbol , charge the battery pack as soon as possible. The instrument automatically shuts off when batteries are too weak for reliable operation. Settings are saved and restored when the instrument is turned on again. When testing in remote locations, always carry a spare battery pack.

Note: By connecting the optional Power Adapter, the instrument can be operated using an AC power source. This adapter is connected to the instrument through the AC Power Adapter Port shown in Figure 1.

1.2 Powering the Instrument On and Off

Press  to power the instrument on and off.

IMPORTANT: To power off the Phasor XS, press and hold the  button for three seconds.

To select an operating mode, choose from:

Phased Array Mode—Adjust all parameters related to phased-array measurement

Conventional Mode—Adjust all parameters related to conventional ultrasonic measurement (see Chapter 4)

See Section 1.6 to set the mode in which the instrument starts up.

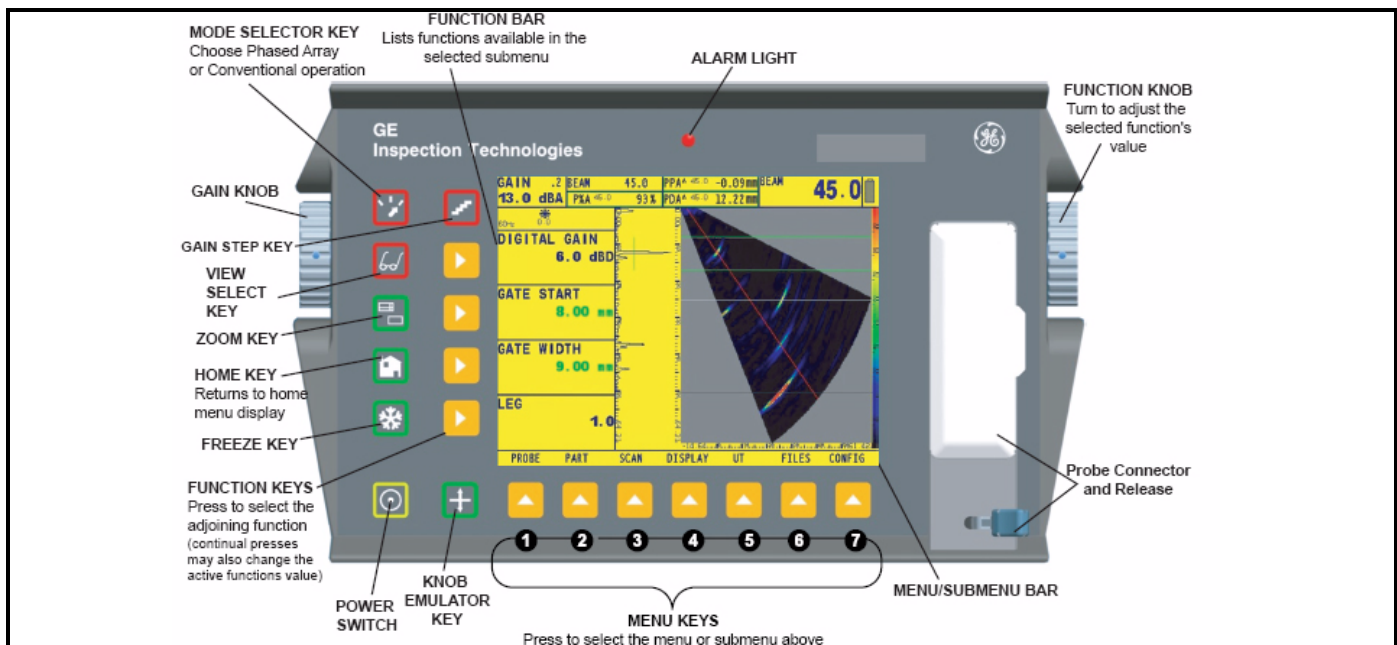





Figure 2: Display of Phasor Case and General Buttons

1.3 Keypad and Knob Features

The instrument is designed to give the user quick access to all of the instrument's functions. Its easy-to-use menu system allows any function to be accessed with no more than three key presses (Figure 2 on the previous page). To access any function:

- Press one of the seven menu keys  to select a menu. The menus across the bottom of the display will immediately be replaced with the submenus contained in the selected menu.
- Press a menu key  again to select the submenu containing the desired function.
- Up to four functions will be displayed in the bar on the left side of the display. Select the desired function, by pressing one of the four function keys .
- Change the value listed in the function box with the function knob. Some values can also be adjusted with repeated presses of the function key.

You'll also find these keys and knobs on the instrument:

—*Gain Step Key* selects the amount of gain level change that occurs with each click of the Gain Knob. Press and hold to switch between digital (dBD) and analog (dBA) gain. Section 3.5 explains gain setting and the use of the dB REF feature.

—*Mode Selector Key* press to choose from Phased Array or Conventional Ultrasonic Operating Modes

—*View Select Key* press and hold to change the displayed view in phased array mode. (choose from Sector or Linear Scan, A-Scan, or A-Scan with Sector or Linear Scan)

—*Zoom Key* press and hold to expand the displayed image (A, Sector, or Linear Scan) to fill the entire screen. Press again to return to normal view mode.

—*Home Key* immediately returns the instrument to the Home Menu shown in Figure 3 on page 5 (Phased Array) or Figure 3 on page 5 (Conventional). If held for 3 seconds, automatically performs a scan calculation. If pressed two times, all functions are de-selected and the Function Knob controls the beam cursor (Section 3.3).

—*Freeze Key* freezes and unfreezes the display. If held for 3 seconds, automatically generates a report or stores a dataset. (Sections 3.4 and 6.1)

—*Power Key* turns the instrument on and off.

—*Knob Emulator Key* switches from the Home Menu to the Knob Menu, which allows you to perform Knob functions using the keypad (both knobs are disabled).

Function Rotary Knob—Rotate to change the value of the selected function. (See Section 3.6 to disable this knob.)

Gain Rotary Knob—Rotate to change the instrument's gain. (See Section 3.6 to disable this knob.)





1.4 Home Menu and Functions

The menu system allows the operator to select and adjust various features and instrument settings. It includes:

Phased Array Home Menu—Several menus used to configure and calibrate the instrument prior to test. Also used to select pulser and receiver characteristics, position gates, set alarms, specify operating mode and screen appearance, adjust the A-Scan display, and control other significant measurement features.

Note: Figure 3 on page 5 shows the instrument's Home Menu structure. The information provided in the following two manual sections explains what each function does and shows how to access the function through the menu system. You'll also find operation-manual section references that tell you where to turn in this manual for more specific information on each function.

The *Phased Array Home Menu System* consists of several menus, submenus, and functions.

- If not displayed, phased array mode is activated by first pressing , then selecting PHASED ARRAY.
- Available menus are accessed via the phased array *Home Menu* (Figure 3 on page 5)
- Each menu contains several submenus.
- Menus and submenus are selected by pressing  below the desired item.
- When a submenu is selected, the functions contained in that submenu are listed in the *Function Bar* down the left-hand side of the display screen.
- Functions are then selected by pressing the adjacent *Function Key* .
- Turning the *Function Knob*, and in some cases continuing to press , will change the value shown in the selected function's box. Pressing and holding  will set some functions to zero.

1.4 Home Menu  and Functions (cont.)

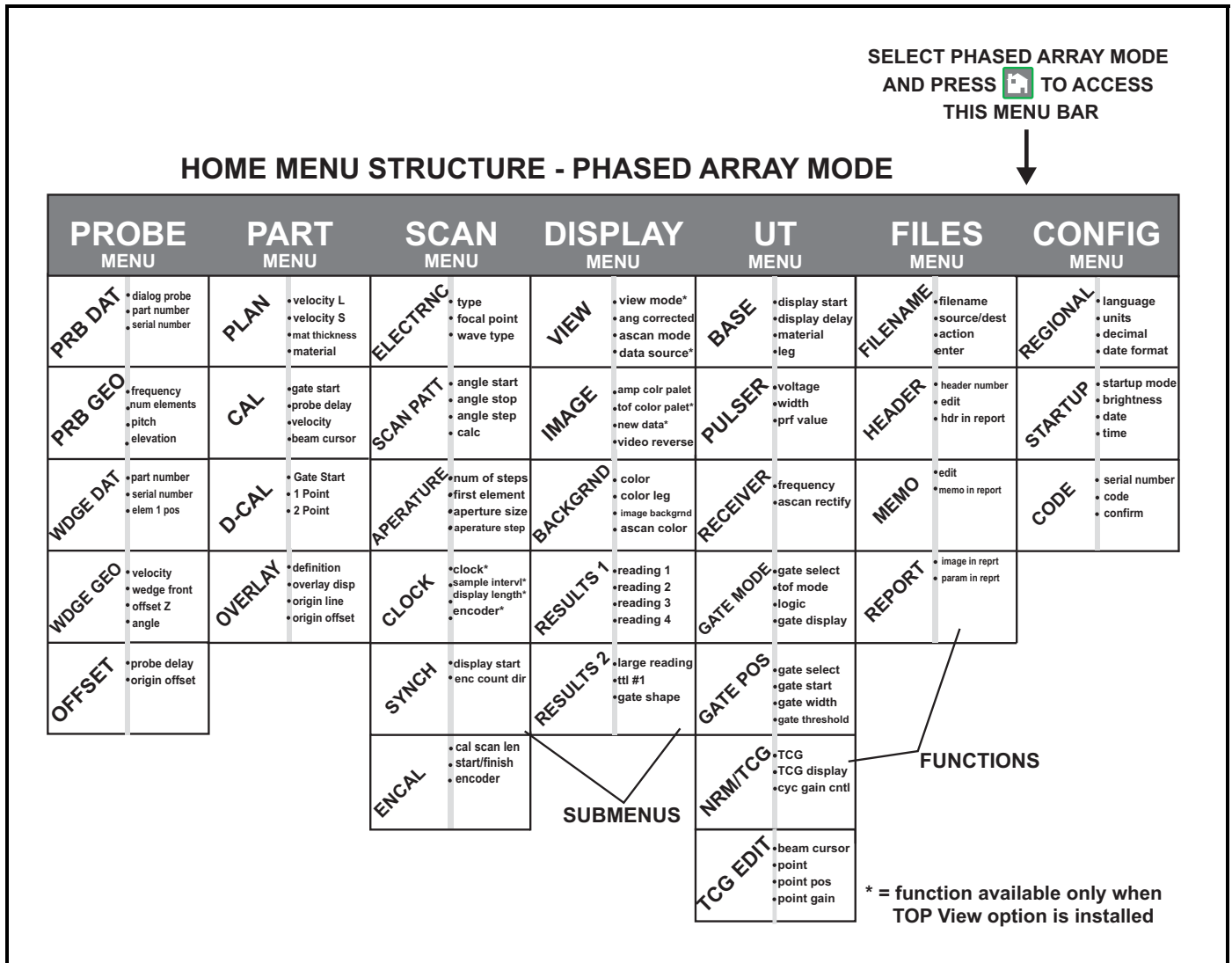





Figure 3: These menus, submenus, and functions are accessed through the Home Menu.

Home Menu

(Functions displayed whenever  is pressed)

- **DIGITAL or ANALOG GAIN**—Press and hold  to select analog or digital gain adjustment with the Gain Knob. Alternative gain setting is controlled with this function. Press and hold  to enter dB REF mode. (Refer to Section 3.6)
- **GATE START**—Sets the beginning position of the selected gate. Gate selected (A, B, or IF) indicated by color of function's text (Refer to Section 2.8.1)
- **GATE WIDTH**—Sets the width of the selected gate. Gate selected indicated by color of function's text (Refer to Section 2.8.1)
- **LEG** – Sets the number of ultrasonic legs displayed, modifying the displayed range (Refer to Section 2.6.1)

Probe Menu

PRB DAT Submenu (Refer to Section 2.3)

- **DIALOG PROBE**— Loads dialog definition file stored in dialog probe
- **PART NUMBER**—Attached probe's part number
- **SERIAL NUMBER**—Attached probe's serial number

PRB GEO Submenu (Refer to Section 2.3.2)

- **FREQUENCY**—Frequency of the attached probe
- **NUM ELEMENTS** —Total number of elements in the attached probe
- **PITCH**—Distance between the centers of two adjacent elements
- **ELEVATION**—Width of element (s)

WDGE DAT Submenu (Refer to Section 2.3.3)

- **PART NUMBER**— Attached probe wedge's part number
- **SERIAL NUMBER**—Attached probe wedge's serial number
- **ELEM 1 POS**—Position of probe's element 1 relative to wedge

WDGE GEO Submenu (Refer to Section 2.3.3)

- **VELOCITY**—Velocity of sound in wedge material
- **WEDGE FRONT**—Distance from wedge front to probe's centerline—which is indicated by a scribed line on the side of the wedge
- **OFFSET Z**—Distance from probe's center to the bottom of the wedge
- **ANGLE**—Angle of probe wedge

OFFSET Submenu

- **PROBE DELAY**—Adjusted during the calibration process to exactly set the time delay required to calibrate the time of flight measurements and correctly indicate reflector location in the image.
- **ORIGIN OFFSET**—Defines the distance from an artificially designated zero position (such as the center of a weld) to the projection point of a reflector in the gate. Setting equal to zero sets the probe's front edge as the zero position.

*Part Menu**PLAN Submenu (Refer to Section 2.4)*

- **VELOCITY L**— Longitudinal velocity of sound in the part under test
- **VELOCITY S**—Shear (Transverse) velocity of sound in the part under test
- **MAT THICKNESS**—Thickness of part under test
- **MATERIAL**—Select the material being tested and the typical sound velocities (for both longitudinal and shear waves) are automatically entered. The correct values will be determined during calibration.

CAL Submenu (Refer to Section 2.9)

- **GATE START** – Sets the beginning position of the selected gate
- **PROBE DELAY** – Adjusted during the calibration process to exactly set the time delay required to calibrate the time of flight measurements and correctly indicate reflector location in the image.
- **VELOCITY** – Longitudinal or shear velocity of sound in the part under test.
- **BEAM CURSOR** – Sound-path beam angle for which the calibration process occurs.

D-CAL Submenu (Refer to Section 2.9.1)

- **GATE START** — Adjust the start position of Gate A
- **1-POINT** — Select to start a 1-point D-CAL (only calibrates probe delay for each beam)
- **2-POINT** — Select to start a 2-point D-CAL (calibrates the material velocity and each beam's probe delay)

OVERLAY Submenu (Refer to Section 2.10)

- **DEFINITION** - Activates the weld overlay wizard
- **OVERLAY DISP** - Shows or hides weld overlay on the image
- **ORIGIN LINE** - Displays a line on the image corresponding to the wedge front, plus origin offset
- **ORIGIN OFFEST** - User defined distance to target location

Scan Menu

ELECTRNC Submenu (Refer to Section 2.4)

- **TYPE**—Identify sector or linear scan type
- **FOCAL POINT**—Depth into the test piece at which the beam focuses
- **WAVE TYPE**—Identify longitudinal or shear soundwave type

SCN PATT Submenu (Refer to Section 2.5)

- **ANGLE START**—Sector scan's starting angle (or fixed angle for linear scan)
- **ANGLE STOP**—Sector scan's ending angle
- **ANGLE STEP**—Step size at which shots are taken between starting and ending angles
- **CALC**—Causes instrument to calculate delay period between element firing

aperture Submenu (Refer to Section 2.5)

- **NUM OF STEPS**—Number of steps taken through the elements in the attached probe
- **FIRST ELEMENT**—Number of the physical element from which the scan begins
- **aperture SIZE**—Number of elements to be fired in scan step (including the first element)
- **aperture STEP**—Number of elements to step per cycle during the scan

CLOCK Submenu (Refer to Chapter 8)

- **CLOCK**—Set TOP View to operate in, TIMED, TIMED CONT. or ENCODED mode.
- **SAMPLE INTERVL**—Speed at which the display scrolls during a TIMED TOP View or the spacing between data acquisition during ENCODED TOP View.
- **DISPLAY LENGTH**—Amount of viewable data (in terms of scanning time or calculated part length) shown on the TOP View display at one time.
- **ENCODER**—Defines the (optional) encoder's operating characteristic.

SYNCH Submenu

- **DISPLAY START**—Sets the display's starting position to match the Initial Pulse or IF gate trigger (for linear scans) or the place where sound enters the test material (all scans) (Refer to Section 2.6.3.)
- **ENC COUNT DIR** — indicates that the encoder counter should use the scan direction as the encoder is wired (NORMAL-default value), or that the encoder counter should reverse the scan direction (REVERSE).

ENCODER CAL Submenu

- **CAL SCAN LEN** - User specified, encoder scan distance
- **START/FINISH** - Begins/ends the recording of the encoder calibration
- **ENCODER** - Defines the encoder's operating characteristic

*DISPLAY Menu**VIEW Submenu*

- **VIEW MODE**—Select standard phased array or optional TOP View (Chapter 8) display

Note: To avoid accidental changes, Phasor XS disables the right knob when the **VIEW MODE** parameter is selected. If the user does turn the knob, the instrument will display the message: **PRESS FUNCTION KEY TO CHANGE VIEW MODE.**

- **ANG CORRECTED**—Select straight down or angle corrected sector scan (Refer to Section 2.3.2)
- **ASCAN MODE**—BUD (beam ultrasonic depth) setting causes the A-Scan (if displayed) to be scaled to the depth of any reflector in the selected beam (Refer to Section 3.6). PEAK setting is only available with the optional TOP View (Chapter 8)
- **DATA SOURCE**—Selects amplitude or TOF data to appear in the optional TOP View (Chapter 8)

IMAGE Submenu (Refer to Section 2.2)

- **AMP COLOR PALET**—Adjusts the range of colors used to depict the measured amplitude
- **TOF COLOR PALET**—Adjusts the range of colors used to depict the time-of-flight (TOP View only, Chapter 8)
- **NEW DATA**—Indicate where “newest” data appears on screen as it's added during scrolling (TOP View only, Chapter 8)
- **VIDEO REVERSE**—Reverses sector, linear, or A scan's orientation

BACKGRND Submenu

- **COLOR**—Changes the background and border colors of the display (Refer to Section 2.2)
- **COLOR LEG**—Displays leg lines on Sector or Linear Scans to indicate in which leg a reflector is located. (Refer to Section 2.6.1)
- **IMAGE BACKGRND**—Sets the display's background color
- **A-SCAN COLOR**—Adjusts the color of the A-Scan (Section 2.2)

RESULTS1 Submenu (Refer to Section 3.2)

- **READING 1 THROUGH READING 4**—Selects the measurement displayed in each of the four small Reading Boxes.

RESULTS2 Submenu

- **LARGE READING**—Select the contents for display in the Large Reading Box. (Refer to Section 3.2)
- **TTL #1**—Identifies in which gate an event triggers TTL 1 and illuminates the Warning Light. (Refer to Section 2.8.5)
- **GATE SHAPE**—Limits A- or B-Gate functionality to detect only those triggers that appear on the display or allows the gates to detect all triggers that fall within the specified test-material range (Refer to Section 2.8.4)

UT MENU

BASE Submenu

- **DISPLAY START**—Sets the display’s starting position to match the Initial Pulse or IF gate trigger (for linear scans) or the point at which sound enters the test material’s surface (all scans) (Refer to Section 2.6.3)
- **DISPLAY DELAY**—Shifts the Scan viewing window to ignore or display initial material thickness (Refer to Section 2.6.2)
- **MATERIAL**—Selects the material being tested. Choose designations with “T” (transverse) for angle beam probes. Sets velocity to value that approximately matches material specified. (Refer to Section 2.4.)
- **LEG**—Sets the number of ultrasonic legs displayed, modifying the displayed range. (Refer to Section 2.6.1)

PULSER Submenu (Refer to Section 2.7)

- **VOLTAGE**—Sets pulser voltage level
- **WIDTH**—Sets width of square pulse
- **PRF VALUE**—Displays and/or allows adjustment of the Pulse Repetition Frequency.

RECEIVER Submenu (Refer to Section 2.7)

- **FREQUENCY**—Selects the frequency filter of the instrument.
- **ASCAN RECTIFY**—Selects the rectification-mode which effects how the A-Scan appears on the display.

GATEMODE Submenu

- **GATE SELECT**—Select A, B, or IF gates (Refer to Section 2.8)
- **TOF MODE**—Indicates whether the triggering echo’s flank or peak is used when making sound-path measurements. (Refer to Section 2.8.2)
- **LOGIC**—Determines whether the gate alarm is triggered when a signal crosses the gate or does not cross the gate. (Refer to Section 2.8.3)
- **GATE DISPLAY**—Shows or hides selected gate. Gate continues to function, even when hidden.

GATE POS Submenu (Refer to Section 2.8)

- **GATE SELECT**—Select from A, B, or IF gates
- **GATE START**—Sets the beginning position of the selected gate.
- **GATE WIDTH**—Sets the width of the selected gate.
- **GATE THRESHOLD**—Sets the height of the selected gate as a percentage of full-screen A-Scan height.

NRM/TCG Submenu (Refer to Section 3.7.)

- **TCG**—Turns on or off the effect of TCG
- **TCG DISPLAY**—Turns on or off the displayed TCG amplifier curve
- **CYC GAIN CNTL**—Used during TCG recording. Applies defined gain slope across the entire range of cycles.

TCG EDIT Submenu (Refer to Section 3.7.))

- **BEAM CURSOR**—Select the beam to be edited
- **POINT**—Alter an existing point or create a new one
- **POINT POS**—Input or modify the time-based position of a TCG point
- **POINT GAIN**—Input or modify the applied gain of a TCG point

*FILES Menu**FILENAME Submenu (Refer to Section 6.1)*

- **FILENAME**—Select stored files or input new data set or report name.
- **SOURCE/DEST**—Indicates the device to or from which data is sent.
- **ACTION**—Recalls or deletes the selected file and saves edits to data sets and reports.
- **ENTER**— Causes specified ACTION to occur.

HEADER Submenu (Refer to Section 6.5)

- **HEADER NUMBER**—Selects the Header Line to edit.
- **EDIT**—Set to YES to allow editing of the selected Header Line.
- **HDR IN REPORT**—Determines if the header will be included in the generated report.

MEMO Submenu (Refer to Section 6.4)

- **EDIT**—Allows editing / creation of the Memo.
- **MEMO IN REPORT**—Determines if the memo will be included in the generated report.

REPORT Submenu (Refer to Section 6.6)

- **IMAGE IN REPORT**—Determines if the displayed Scan(s) will be included in the generated report.
- **PARAM IN REPORT**—Determines if instrument settings will be listed in the generated report.

CONFIG Menu

REGIONAL Submenu (Refer to Section 2.1)

- **LANGUAGE**—Sets the language displayed on the instrument's screen
- **UNITS**—Sets displayed units to inch or millimeters
- **DECIMAL**—Select a period or comma for use as a decimal point.
- **DATE FORMAT** —How the date and time are displayed

STARTUP Submenu

- **STARTUP MODE**—Indicates if instrument is to start in the last active mode or at the Welcome Screen (Refer to Section 4.3)
- **BRIGHTNESS**—Adjusts the display's brightness (refer to Section 2.2)
- **DATE** —Sets the displayed date (Refer to Section 2.1)
- **TIME** —Sets the displayed time (Refer to Section 2.1)

CODE Submenu

- **SERIAL NUMBER** - Serial number of the instrument (cannot be edited)
- **CODE** - Allows for entry of code to enable options
- **CONFIRM** - Confirms entry of code

1.5 Display Screen Features (Phased Array)

The instrument's display screen is designed to be easy to interpret. In Figure 4 below you'll find an example of a display configuration. This specific display includes an active A-Scan and Sector Scan combination and the HOME menus. Refer to this figure for an explanation of those screen features you'll most often encounter. Pressing and holding allows you to modify the displayed view to include A-Scans, Sector or Linear Scans, or a combination of these.

Definition of Display Icons

There are several graphical features (icons) which appear in the display screen's for various reasons. Figure 5 on page 14 includes several of these icons along with an explanation of their significance.

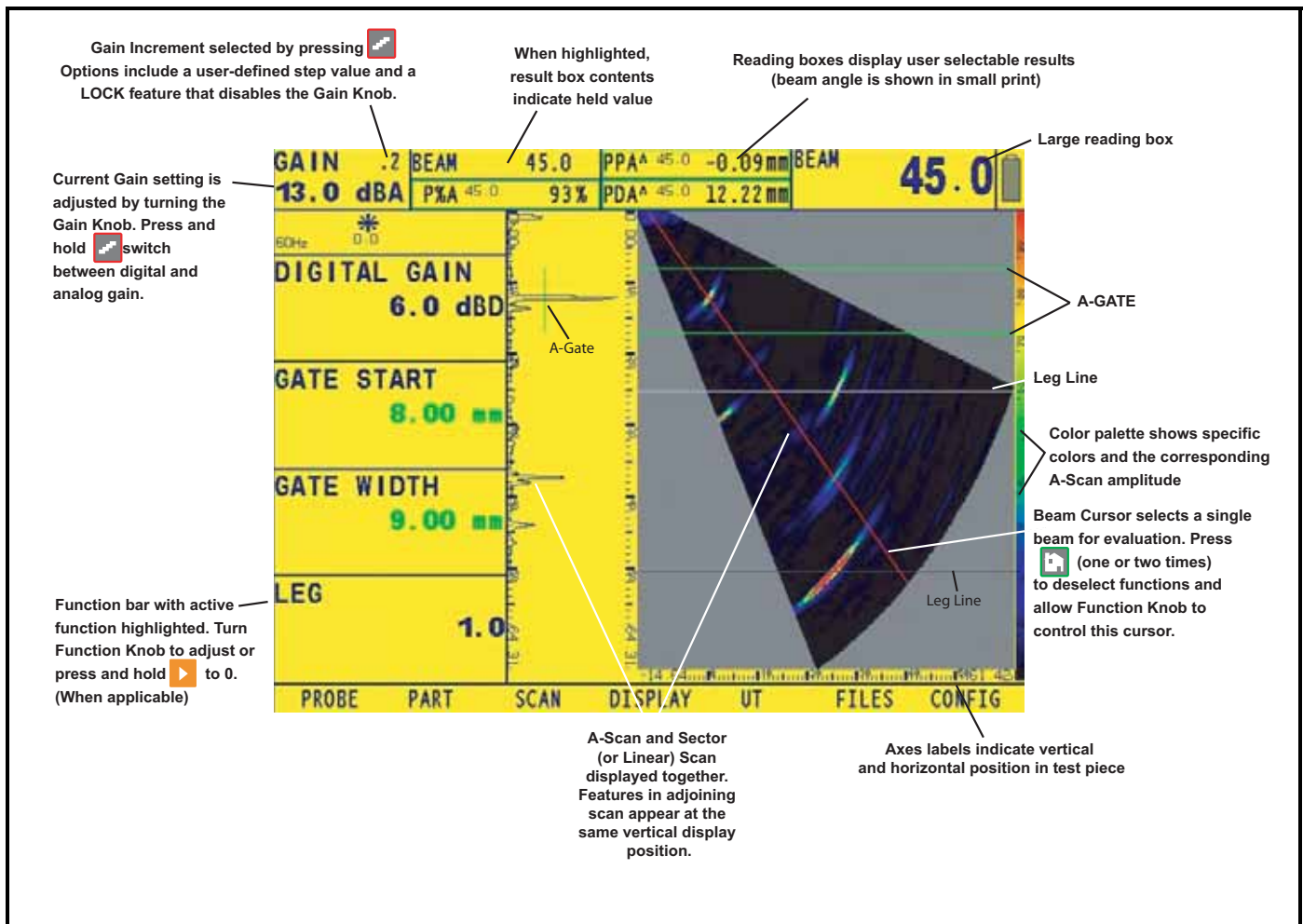

Figure 4: Combined A-Scan and Sector Scan views are shown here. Note that alternative views (showing either A or Sector or Linear scans) are available when operating in Phased Array mode.

1.6 Startup Mode

Each time the instrument is powered on, the WELCOME screen is displayed. This screen allows the user to select PHASED ARRAY, CUSTOM or CONVENTIONAL mode. Alternatively, the instrument can be configured to automatically start in the previously active mode. To set the START UP mode:

Step 1: Activate the STARTUP Submenu (Located in the CONFIG MENU) by pressing  below it. Selections will appear down the left side of the display.

Step 2: Press  next to STARTUP MODE to select one of the following:

WELCOME – Display allows the user to select PHASED ARRAY, CUSTOM or CONVENTIONAL operation each time the instrument is powered on.

LAST – Instrument automatically powers on in the mode that was last active.

At any time, the operating mode can be changed by pressing  to access the WELCOME screen.

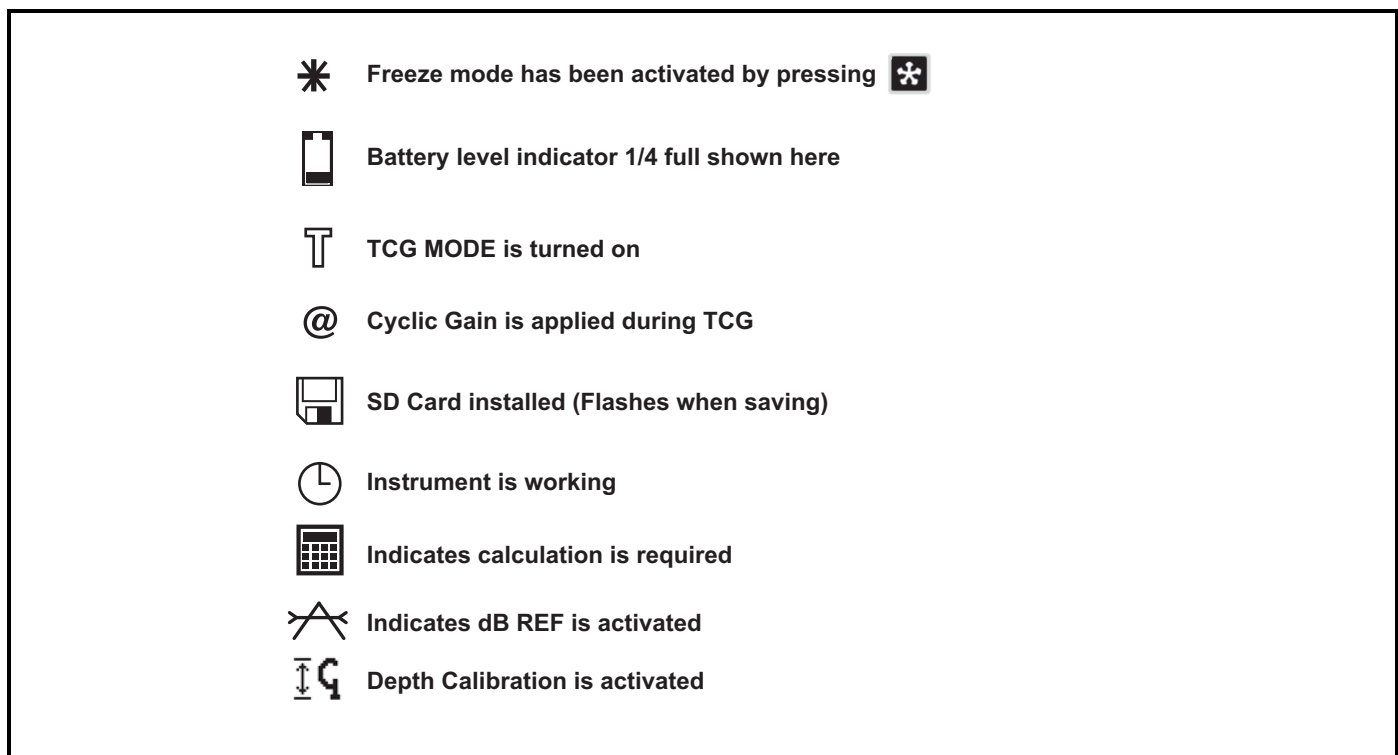



Figure 5: These icons appear on the display at various times.

1.7 Software Updates

If software updating is required, the instrument's updated software can be downloaded from our website: <http://www.geinspectiontechnologies.com/>. Click on the Download Center link at the bottom of your screen

1.7.1 Phasor XS Software Upgrade Procedures

1. Copy the Phasor XS upgrade file (.sdu) to the root directory of an SD card. For proper operation, only one .sdu file should be present on the SD card.
2. Insert the SD Card into rear of the Phasor XS instrument.
3. With the Phasor XS turned off, press and hold the Home and Power  keys until the red LED illuminates.

Note: “Flash Upgrade Mode/Loading File” should be displayed. If it is not, turn off the instrument and ensure that the HOME key is pressed first and held. Then press and hold the Power key again. The upgrade process will take approximately 5 minutes, and the lines of operating code can be seen upgrading on the screen of the Phasor XS. The instrument will automatically shut off when upgrade process is completed.



4. Press and hold the Mode Selector  key and Power  keys for approximately 5 seconds until the message “Instrument Reset – Last Setup Ignored” is displayed to reset the instrument. The new version of operating software will also be displayed.

Your instrument is now fully upgraded, reset, and ready to use.

1.7.2 Phasor XS Upload Code Upgrade Procedure

Note: If your instrument has upload code version less than 2.50, only FAT16 formatted SD card with capacity less than 1 GB can be used for the upgrade process. Once the upload code is upgraded to 2.50, you can use FAT32 formatted SD cards up to 32 GB for the upgrade process.

IMPORTANT: Before starting the upgrade process, make sure your Phasor XS is connected to the power supply or has a fully charged battery. If the upgrade process is not completed successfully, you might have to send your instrument for service.

1. Copy the Phasor XS Upload code upgrade file (.sdu) to the root directory of an SD card. For proper operation only one .sdu file should be present.
2. Insert the SD card into the rear of the Phasor XS.
3. With the Phasor XS turned off, press and hold the Home  and Power  keys until the red LED illuminates.

Note: “Flash Upgrade Mode/Loading File” should be displayed. If it is not, turn off the instrument and ensure the Home key is pressed first and held. Then press and hold the Power key again. The upgrade process will take approximately 1 minute, and the lines of operating code can be seen updating on the screen of the Phasor XS.

The instrument will automatically shut off when the upgrade process is complete.

4. Power up the Phasor XS by pressing the Power  key and verify that the splash screen displays the new version as “Upload Code: 2.50, BLD001 1-OCT-2009” or greater. Your Phasor XS code is now upgraded.



[no content intended for this page - proceed to next page]

Chapter 2. Setting Up for Phased Array Measurement

In this chapter, you'll learn how to configure the instrument's display and operating features in preparation for operating in Phased Array Mode. Because the instrument settings can be stored in a data set (Section 6.1) and restored at any time, you won't have to repeat most of these adjustments. Instead, create a data set to match any probe/wedge (and – if applicable – part) combination you anticipate reusing at a later time.

After reading this chapter, you'll be able to:

- Select the displayed language and units of measurement (Section 2.1)
- Set the date and time (Section 2.1)
- Adjust the display's color and brightness (Section 2.2)
- Connect a Phased Array Probe (Section 2.3)
- Configure the instrument to match the attached phased array probe (Section 2.3.2)
- Configure the instrument to match the attached wedge (Section 2.3.3)
- Input material properties and thickness of the part being tested (Section 2.4)
- Specify scan parameters to control the geometry and direction of the scan (Section 2.5)
- Adjust the display's range and starting point using ultrasonic parameters (Section 2.6)
- Configure ultrasonic parameter settings related to the Pulser and Receiver (Section 2.7)
- Adjust gate position, triggering logic, shape and alarm indication light (Section 2.8)
- Calibrate the instrument/probe/test piece combination to determine actual PROBE DELAY and MATERIAL VELOCITY values (Section 2.9)



Turn on the instrument by pressing . Press  to select Phased Array Mode, if required. The Phased Array Home Menu (see Figure 3 on page 5 for this menu's complete structure) will be activated.

2.1 Language, Units of Measurement, Date, and Time



Use the procedures below to adjust the unit of measurement, the date, the time, and the language that appears on the instrument's display screens and data output. These adjustments will require access to the REGIONAL and STARTUP Submenus. These are accessed from the CONFIG Menu.

Note: Once set, the internal clock will maintain the current date and time.



Setting the Units of Measurement (CONFIG-REGIONAL-UNITS)

1. Activate the REGIONAL Submenu (located in the CONFIG Menu) by pressing  below it. Functions will appear down the left side of the display screen.
2. Press  next to the selection titled UNITS. You'll note that the following options are available:
 - **MM**—default setting displays values in millimeters
 - **INCH**—displays values in inches
3. To change the units of measurement, continue pressing  or turn the function knob.
4. The unit of measurement will be set to the choice last displayed.







Setting the Operating Language (CONFIG-REGIONAL-LANGUAGE)

1. Activate the REGIONAL Submenu (located in the CONFIG Menu) by pressing  below it. Functions will appear down the left side of the display screen.
2. Press  next to the selection titled LANGUAGE. To change the selected language, continue pressing  or turn the function knob. You'll note that the options available are English, German, French, Spanish, Italian, Japanese and Chinese. The default language is English.
3. The display-screen and report language will be set to the choice last selected.





Setting the Date and Time Formats (CONFIG-REGIONAL-DATE FORMAT)

1. Activate the REGIONAL Submenu (located in the CONFIG Menu) by pressing  below it.
2. Press  next to the selection titled DATE FORMAT. To change the selected format, continue pressing  or turn the function knob. Choose from the following date and time formats:
 - Y-M-D (12 or 24 hour time format)
 - M/D/Y (12 or 24 hour time format)
 - D.M.Y (12 or 24 hour time format)
3. The date and time formats shown on the display-screen and in outputted reports will be set to the choice last selected.

Setting the Date (CONFIG-STARTUP-DATE)

1. Activate the STARTUP Submenu (located in the CONFIG Menu) by pressing  below it.
2. Press  next to the selection titled DATE. The date is displayed in the user-selected format. Note that the first time you press , the day character is highlighted. The next time you press , the month character is highlighted. Finally, pressing  again will cause the year character to be highlighted.
3. To change the month, days, or year, turn the function knob while the desired character is highlighted.
4. When complete, press  one more time. The current date will be set to the date displayed.

Setting the Time (STARTUP-CONFIG-TIME)









1. Activate the STARTUP Submenu (located in the CONFIG Menu) by pressing  below it.
2. Press  next to the selection titled TIME. Time is displayed in 24-hour format. Note that the first time you press , the hours character is highlighted. The next time you press , the minutes character is highlighted.
3. To change the hours or minutes setting, turn the function knob while the desired character is highlighted.
4. When complete, press  one more time. The current time will be set to the time displayed.

2.2 Display Appearance

Use the procedures in this section to adjust display appearance. The adjustments will require access to the DISPLAY Menu (shown in Figure 6 on page 21).

Setting the Image Color, Brightness, and Orientation (DISPLAY-IMAGE or -BACKGRND)

The color of displayed images (A-Scan and/or Linear or Sector Scans) can be altered using the IMAGE Submenu. This submenu also allows the user to change the orientation of the displayed image (shifting the sector origin from the left to the right side of the display or the A-Scan starting point from top to bottom, for instance). Similarly, the BACKGRND Submenu allows the user to change the color of the display's background and reading boxes. It also changes the display's brightness.

1. Activate the IMAGE submenu (located in the DISPLAY Menu) by pressing . Functions will appear down the left side of the display screen.
2. Press  next to one of the following functions:
 - AMP COLOR PALET—Select the colors used to represent ranges of amplitude values when sector or linear scans are displayed.
 - VIDEO REVERSE—Reverse the orientation of Displayed Sector Scans (left to right) and Linear Scans.
3. Press  under BACKGRND Submenu, then press  next to one of the following functions:
 - COLOR—Select the display's color scheme, which is applied to the reading boxes.
 - COLOR LEG—Turn the displayed leg lines ON or OFF
 - IMAGE BACKGRND—Sets the background color displayed around the sector scan.
 - ASCAN COLOR—Select the A-Scan's color
4. To change the value of the select function, continue pressing the corresponding  or turning the function knob.
5. Press  under STARTUP (located in the CONFIG menu), then press  next to BRIGHTNESS. Press  or turn the Function Knob to select settings from 1 to 10.
6. The selected function will remain at the value last displayed.

2.2 Display Appearance (cont.)

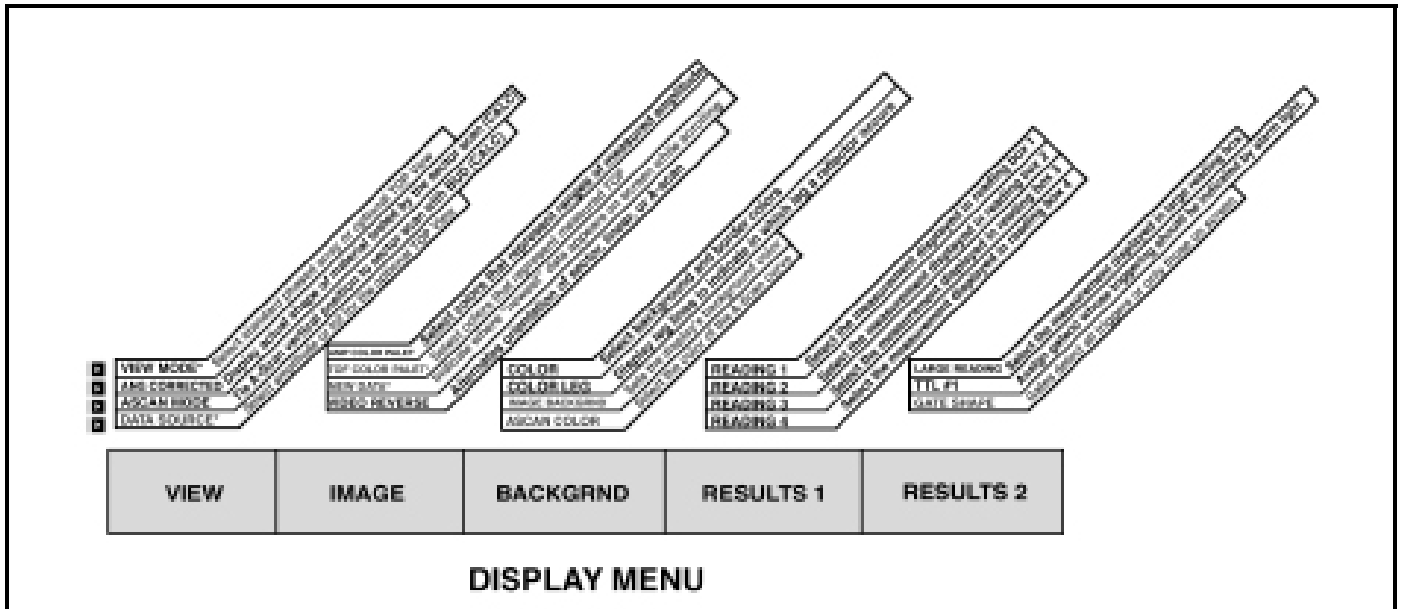



Figure 6: The Display Menu allows the user to adjust most of the instrument's display and measured results when operating in Phased Array mode. Note that altering the value of functions identified with CALC will require a recalculation of delay laws. Also note that functions marked with * are available only when the TOP View option is installed (Chapter 8).

2.3 Installing a Phased Array Probe

Note: *Modifying certain settings related to probe or scan configuration will require a recalculation of the delay laws. When such a change is made, the modified function will turn red, indicating that the effect of this change will not take effect until the new delay-law calculation is carried out. To command a calculation, press and hold for three seconds or access the SCAN PATT Submenu and press  next to the CALC Function.*

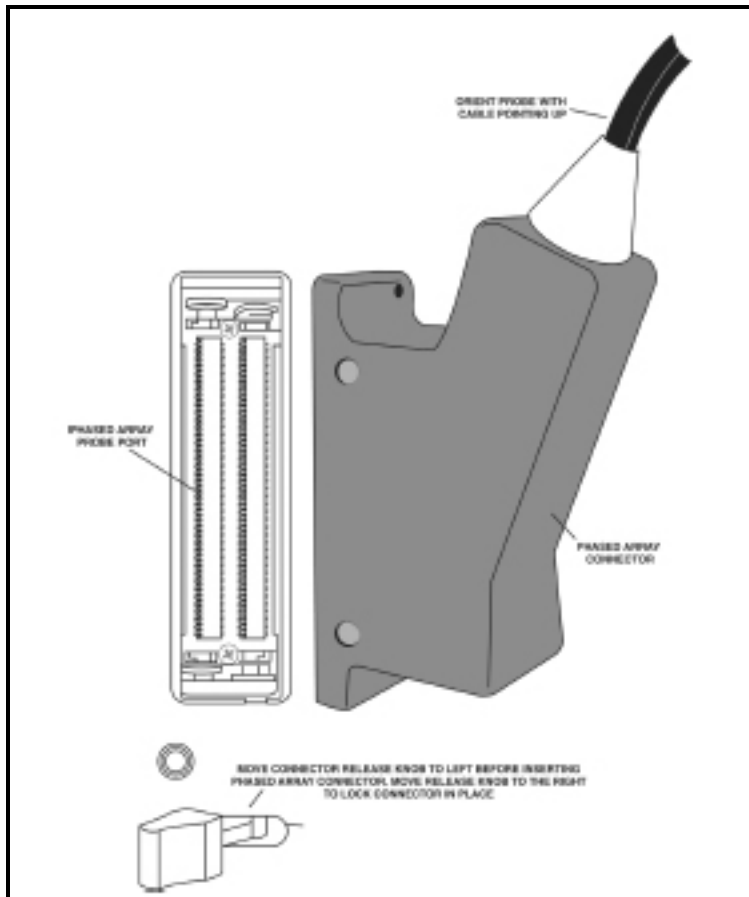

Figure 7: Phased Array Probe Attachment

2.3.1 Connecting a Probe

When connecting a probe to the instrument, it's not only important that the probe's physical connection be properly made, but that the instrument is properly configured to work with the installed probe. To install a phased array probe, connect it to the front of the instrument. Be sure to install it with the probe cable facing up and to operate the probe-release lever as shown in Figure 7 above.

IMPORTANT: *The Phasor XS may fail if a user removes or attaches the probe while the instrument is running. If this occurs, the user will lose any unsaved settings. To protect against this failure, GE recommends that the user power OFF the instrument before attaching or replacing a probe.*

2.3.2 Configuring the Instrument for a Phased Array Probe



When a phased array probe is connected, various instrument settings must be input to match the probe and (if so equipped) its attached wedge. Data related to a probe is printed on its body and connector. Probe-related functions are accessed via the PROBE Menu shown in Figure 8 below. These settings must be adjusted each time a different phased array probe is installed. Note that all probe-related settings can be stored in a data set file as described in Chapter 6.

Note: When a dialog style probe is connected to the instrument, select the dialog load function to set the probe data and the probe geometry.

Note: Probe and wedge geometry, scan parameters, and user-inputted offset values influence the displayed image. The physical relationship between these settings and the displayed image are graphically represented by the Imaging and Measurement Map shown in Section 2.3.3.

Inputting Probe Part and Serial Number (PROBE-PRB DAT-PART or SERIAL NUMBER)

If a dialog probe is connected, select DIALOG PROBE and then HOME BUTTON to automatically set the part number, serial number, frequency, number elements, pitch, and elevation.

1. Activate the PRB DAT Submenu (located in the PROBE Menu) by pressing  below it.
2. Press  next to one of the selections (PART NUMBER or SERIAL NUMBER) two times.
3. To change the active digit of the part or serial number (to match the value printed on the side of the probe connector), turn the Function Knob. To make the next digit active, turn the Gain Knob.
4. Press  again to complete the PART or SERIAL NUMBER entering process.

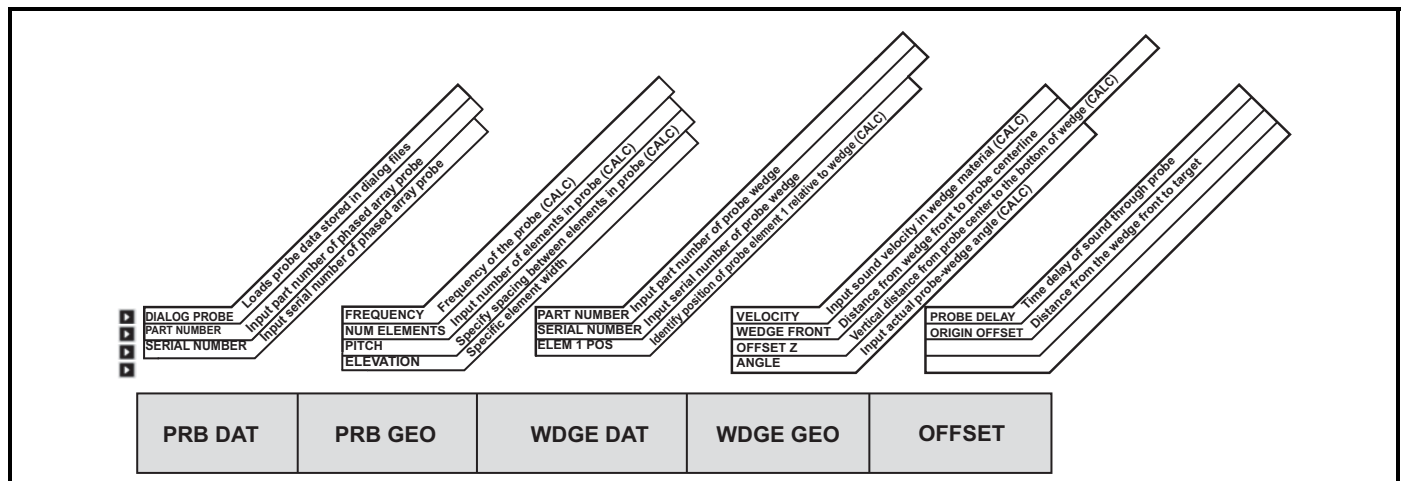



Figure 8: The PROBE Menu allows the user to input settings related to probe and wedge configuration. Delay-law recalculation is required when those functions indicated here with CALC are modified.

Defining the Probe Geometry (PROBE-PRB GEO-FREQUENCY or NUM ELEMENTS or PITCH)

1. Activate the PRB GEO Submenu (located in the PROBE Menu) by pressing  below it. Selections will appear down the left side of the display.
2. Press  next to one of the selections (FREQUENCY or NUM ELEMENTS or PITCH).
3. To change the displayed value (to match that printed on the probe), continue pressing or turning the function knob. You'll note that the following settings are available:

FREQUENCY – 0.5 to 10 MHz



NUMBER of ELEMENTS – 1 to 64

PITCH – distance between the centers of two adjacent elements (approximately 0.010 to 0.197 inches or 0.25 to 5 mm)

4. The selected parameter will be set to the value last displayed. Recalculation of delay laws is required.

Setting the Probe Delay (PROBE-OFFSET-PROBE DELAY)



The Probe Delay Setting represents the time delay caused by sound-wave travel through a probe's wearplate, membrane, delay line, or wedge. The Probe Delay value is set as part of the Calibration process (Section 2.9). To adjust the probe delay:

1. Activate the OFFSET Submenu (Located in the PROBE MENU) by pressing  below it. Selections will appear down the left side of the display.
2. Press  next to PROBE DELAY.
3. Turn the Function Knob to adjust the PROBE DELAY setting.

2.3.3 Inputting Wedge-Related Information



If the connected phased array probe is equipped with a wedge, wedge-related settings must be input by accessing the PROBE Menu (Figure 8 on page 23). These settings must be adjusted each time a different wedge is connected. Most of the wedge-related data is printed on its surface. Note that all wedge-related settings can be stored in a data set file as described in Section 6.1.

Inputting Wedge Part and Serial Number (PROBE-WDGE DAT-PART or SERIAL NUMBER)

1. Activate the WDGE DAT Submenu (located in the PROBE Menu) by pressing  below it.
2. Press  next to one of the selections (PART NUMBER or SERIAL NUMBER) two times. The cursor will illuminate in the first-digit space.
3. To change the value of the active digit of the part or serial number (to match the value printed on the side of the probe connector), turn the Function Knob. To make the next digit active, turn the Gain Knob.
4. Press  again to complete the PART or SERIAL NUMBER entering process.

The orientation of probe elements with respect to the wedge is displayed in Figure 9 on the next page.

Defining the Wedge Geometry (PROBE-WDGE GEO-VELOCITY or OFFSET Z or ANGLE)



1. Activate the WDGE GEO Submenu (located in the PROBE Menu) by pressing  below it. Selections will appear down the left side of the display.
2. Press  next to one of the selections (VELOCITY or OFFSET Z or ANGLE).
3. To change the displayed value (to match that printed on the wedge), continue pressing  or turning the function knob. You'll note that the following settings are available (Figure 9 below):
 - VELOCITY – Input in/ms to match the velocity of sound through the wedge material
 - OFFSET Z – Input inches / mm (must be set to 0 when no wedge is installed) to equal the user-measured dimension from the wedge surface in contact with the test piece to the Probe Index Point.
 - ANGLE – 0.0 to 90 degrees to match the user-measured wedge angle.
4. The selected parameter will be set to the value last displayed. Recalculation of delay laws is required.

Determining and Inputting the Probe-Index-Point to Wedge-Front-Edge Distance (PROBE-WDGE GEO-WEDGE FRONT)

A line scribed on the side of the wedge (see Figure 9 below) corresponds with the probe's index point. The measurement from this line to the wedge's front edge is the WEDGE FRONT dimension. This value must be determined and input before inputting the ORIGIN OFFSET (see next section), which allows the instrument's display to compensate when a probe is offset (by a guide ring, for instance) a fixed distance from the inspection target.

1. Activate the RESULTS1 Submenu in the DISPLAY Menu as set one of the READING values to PA as described in Section 3.2.

Note: Gates must be on.

2. Activate the WDGE GEO Submenu (located in the PROBE Menu) by pressing  below it.
3. Couple to a block with a known reflector (as shown in Figure 9 below). Move the probe until the probe-wedge front is aligned over the reflector (and the reflector is detected). Observe the displayed value of PA.
4. Press  next to the selection WEDGE FRONT.

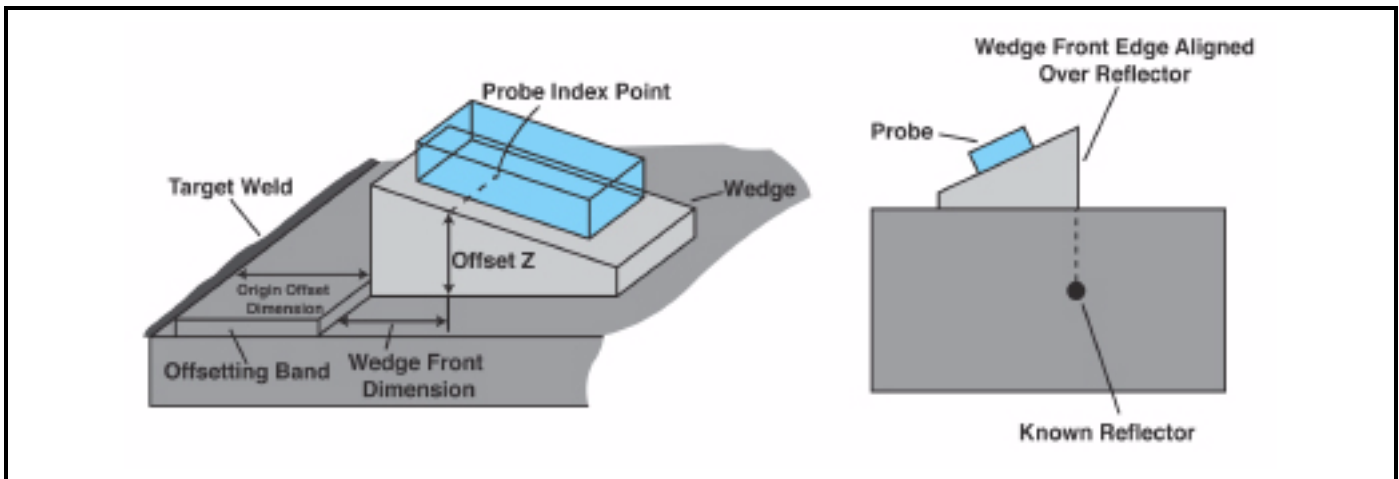

Figure 9: Wedge Geometry is defined here. Manually measure the distance from the Probe Index Point to the front of the wedge to find the WEDGE FRONT value. You must determine this value whenever ORIGIN OFFSET techniques are used.



Determining and Inputting the Probe-Index-Point to Wedge-Front-Edge Distance (PROBE-WDGE GEO-WEDGE FRONT) (cont.)

5. Turn the Function Knob until the displayed value of PA reads zero.
6. Repeat this process to confirm that the displayed value of PA equals zero when the front edge of the probe wedge is aligned with the known reflector. Continue to adjust the WEDGE FRONT value if required.

Note: *The WEDGE FRONT (WF) and ORIGIN OFFSET (OO) settings directly effect the frame of reference from which all projection RESULTS (such as PA) are measured. When a value of 0 is input for both WF and OO, all projection results are measured with respect to the probe index point (PIP). When 0 is input for OO and a numerical value for WF, all projection measurements are with respect to the wedge front. When numerical values are input for both WF and OO, all projection results are measured with respect to the user-defined origin.*



Inputting Probe/Wedge Offset Distance (PROBE-OFFSET-ORIGIN OFFSET)

When an installation calls for a probe/wedge assembly to be offset a fixed distance from an inspection target, the value of the offset (which is typically equal to the width of an installed guide ring) must be manually measured and input. This allows the instrument to compensate for the offset and adjust the display accordingly (Figure 9 on the previous page). Be sure to also measure and input the WEDGE FRONT dimension before setting ORIGIN OFFSET.

1. Activate the OFFSET Submenu (located in the PROBE Menu) by pressing  below it.
2. Manually measure the distance that the front of the wedge is offset from the target.
3. Press  next to the selection ORIGIN OFFSET.
4. Turn the Function Knob until the displayed value matches the manually measured dimension.
5. The value will be set to the last one displayed.

Defining the Probe Element Orientation with Respect to the Wedge (PROBE-WDGE DAT-ELEM 1 POS)

Markings on the probe body will indicate the location of element 1 and the direction in which additional elements are arranged. The orientation of the probe's elements, with respect to the wedge's geometry, is defined using the ELEM 1 POS function. See Figure 10 on page 27 and Figure 11 on page 27.

1. Activate the WDGE DAT Submenu (located in the PROBE Menu) by pressing  below it.
2. Press  next to the selection ELEM 1 POS.
3. Continue to press  or turn the Function Knob to select one of the following:
 - **LOW END** -- The position of Element 1 is indicated on the probe body at a location corresponding to the low (thinnest) side of the wedge. Remaining elements are arranged towards the high (thickest) side of the wedge. (Figure 10 on page 27)
 - **HIGH END** -- The position of Element 1 is indicated on the probe body at a location corresponding to the high (thickest) side of the wedge. Remaining elements are arranged towards the low (thinnest) side of the wedge. (Figure 11 on page 27)
4. Probe element orientation will be defined as last displayed. Recalculation of delay laws is required.

Defining the Probe Element Orientation with Respect to the Wedge (PROBE-WDGE DAT-ELEM 1 POS) (cont.)

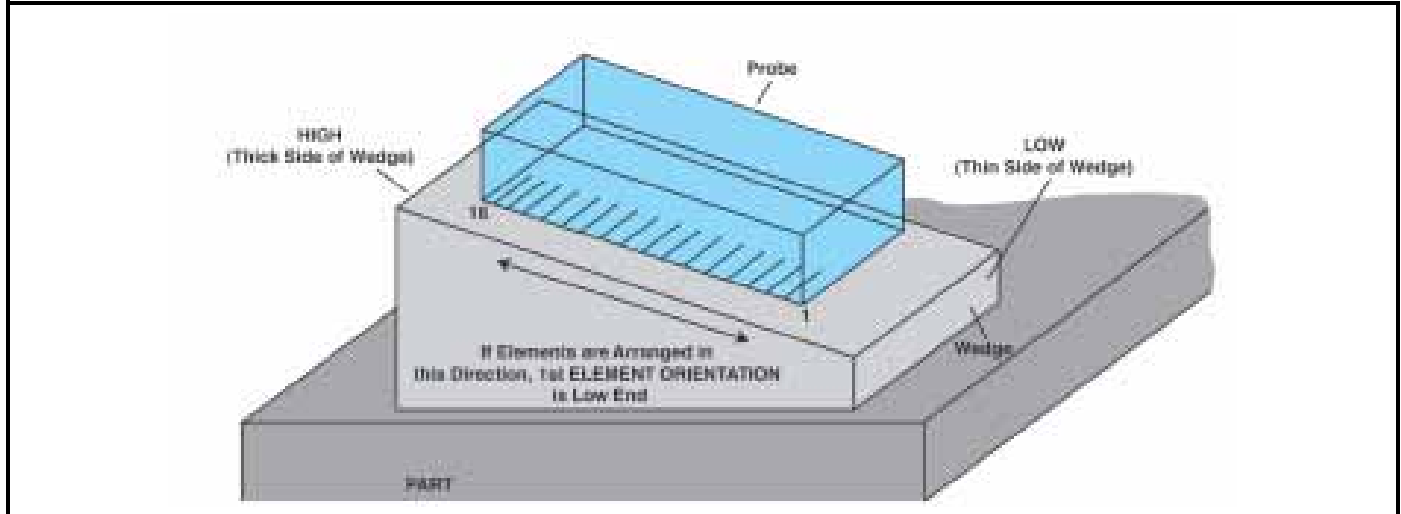

Figure 10: ELEM 1 POS setting identifies the location of the probe's first element and describes the direction in which remaining elements are arranged. In this case the first element is located at the edge of the probe that corresponds to the LOW (thin) side of the wedge with additional elements arranged towards the high (thick) side of the wedge.

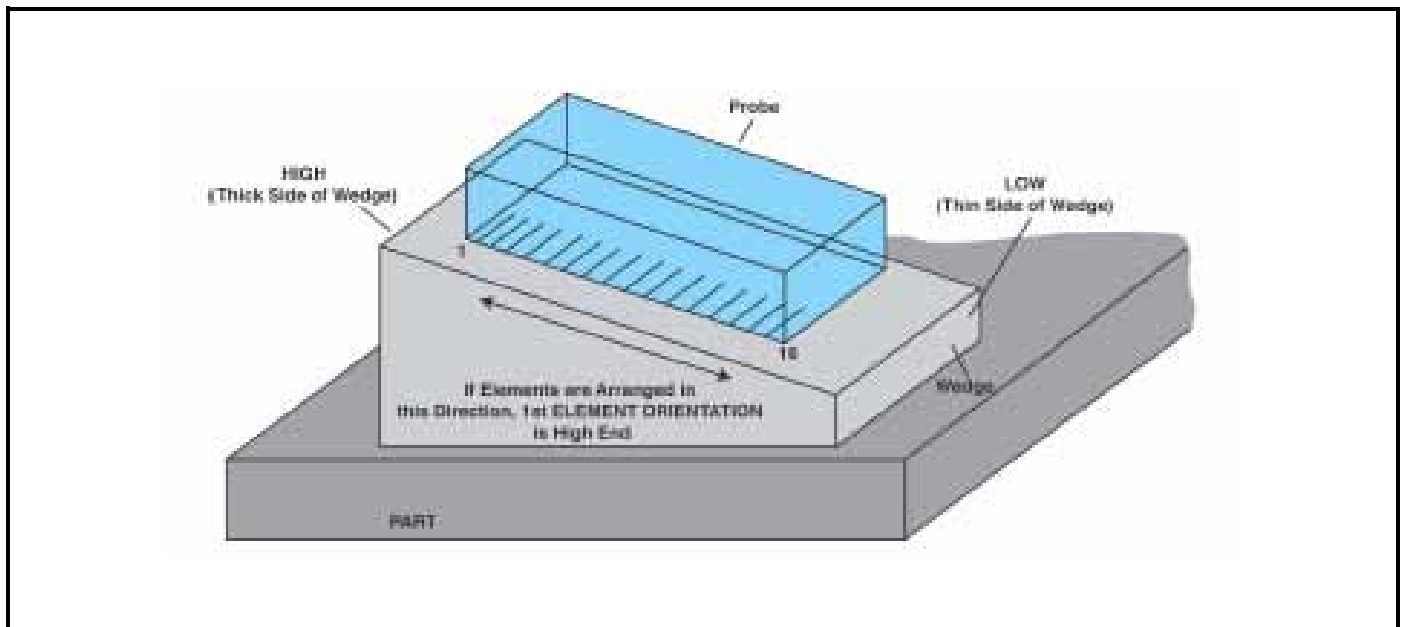
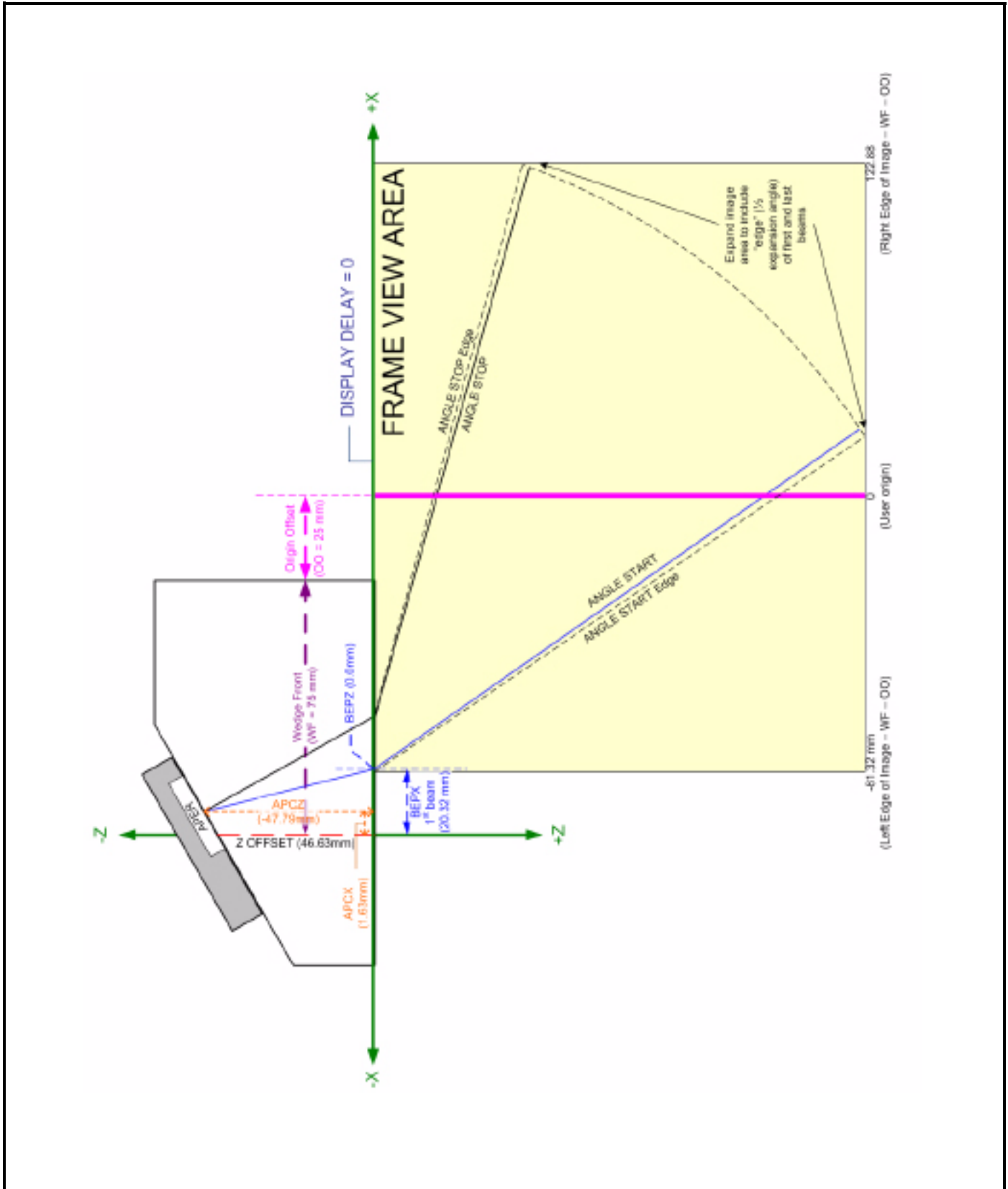



Figure 11: ELEM 1 POS setting identifies the location of the probe's first element and describes the direction in which remaining elements are arranged. In this case the first element is located at the edge of the probe that corresponds to the HIGH (thick) side of the wedge with additional elements arranged towards the low (thin) side of the wedge.





2.4 Inputting Test-Piece Properties

To correctly determine the physical location at which a reflector occurs, the test piece's thickness and material type (indicating shear and longitudinal velocities of sound in the test piece) must be input. These parameters directly affect the displayed range and the calculated trig values.



Inputting Part Thickness (PART-PLAN-MAT THICKNESS)

1. Activate the PLAN Submenu (located in the PART Menu) by pressing  below it.
2. Press  next to the selection MAT THICKNESS.
3. Turn the Function Knob to change the thickness to match the part under test.
4. The inputted thickness will be set to the last value displayed.



Specifying Part Material Type (PART-PLAN-MATERIAL)

1. Activate the PLAN Submenu (located in the PART Menu) by pressing  below it.
2. Press  next to the selection MATERIAL.
3. Turn the Function Knob or continue to press  until the material type listed matches the part under test.
4. The longitudinal and shear acoustic velocities will be set to the average value of the material type displayed. Note that the displayed values are only an approximate and should be fine-tuned to more closely match the actual velocities of sound through the material under test. Changes to VELOCITY L or VELOCITY S will require recalculation of delay laws.

Defining the Speed of Sound in the Test Part (Longitudinal and Shear Velocity) (PART-PLAN-VELOCITY L or VELOCITY S)

1. Activate the PLAN Submenu (located in the PART Menu) by pressing  below it.
2. Press  next to either the VELOCITY L or the VELOCITY S selection.
3. Turn the Function Knob until the velocity listed matches the speed of sound in the part under test.
4. The longitudinal and transverse acoustic velocities will be set to the value last displayed. Changes to VELOCITY L or VELOCITY S will require recalculation of delay laws.

2.5 Defining the Scan Parameters

Note: *Modifying certain settings related to probe or scan configuration will require a recalculation of the delay laws. When such a change is made, the modified function will turn red, indicating that the effect of this change will not take effect until the new delay-law calculation is carried out. To command a calculation, press and hold  for three seconds or access the SCAN PATT submenu and press  next to the CALC Function.*

When operating in Phased Array mode, the sequence and pattern at which the probe's elements fire are defined by the scan parameters (SCAN Menu). This section describes the process for setting these parameters and the effect of their settings on the instrument's function. The following scan parameters are represented graphically in Figure 12 and Figure 13 on the next page and described in greater detail below:

LINEAR SCAN TYPE – Controlled firing of multiple elements at a constant angle (Figure 12)

SECTOR SCAN TYPE – Constant-sized groups of elements (said to represent a constant “aperture”) are fired at varying angles (Figure 13)

FOCAL POINT – Depth into the part at which the phased array focuses. This depth represents an area of interest. It can be set to UNFOCUSED (by holding  for approximately three seconds) for typical phased-array applications (Figure 14).

Note: *Focal points are valid within the natural nearfield length N of the selected aperture where:*

$$\frac{(N = D_{\text{eff}}^2)}{4c} \text{ for circular transducers}$$

$$N = \frac{1.3a^2f}{4c} \text{ for square transducers}$$

where:

D_{eff} = effective transducer diameter

a = side length of the transducer

f = resonance frequency of the transducer

c = sound velocity in the test object

2.5 Defining the Scan Parameters (cont.)

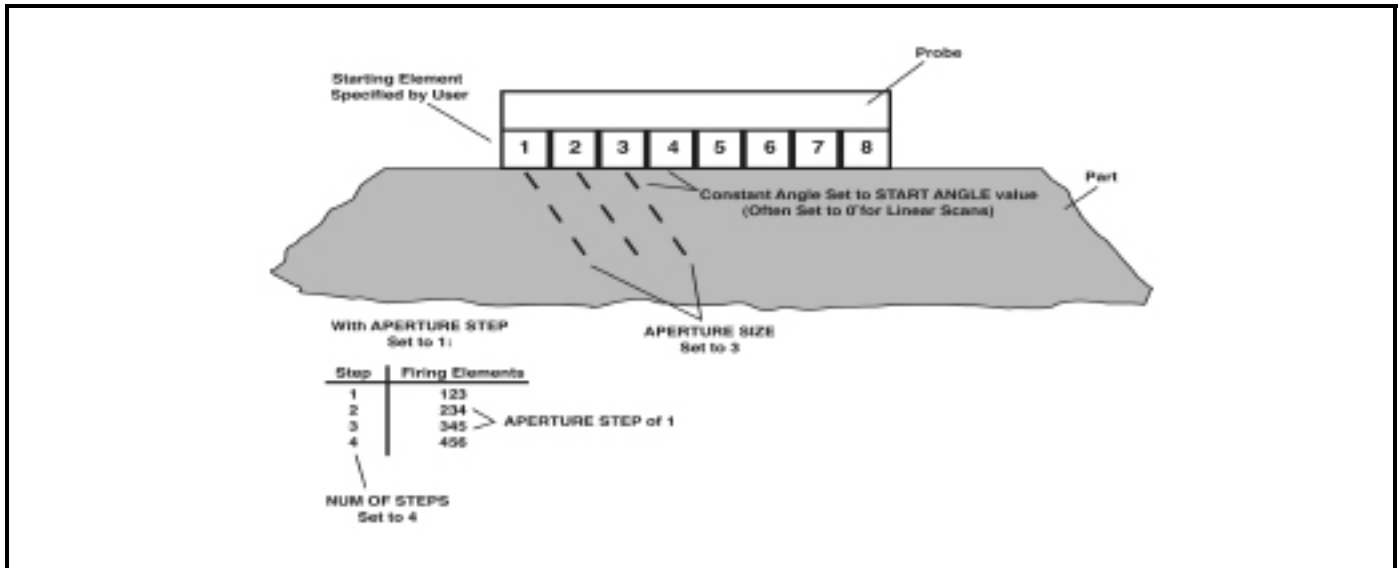

Figure 12: Linear Scan Parameters

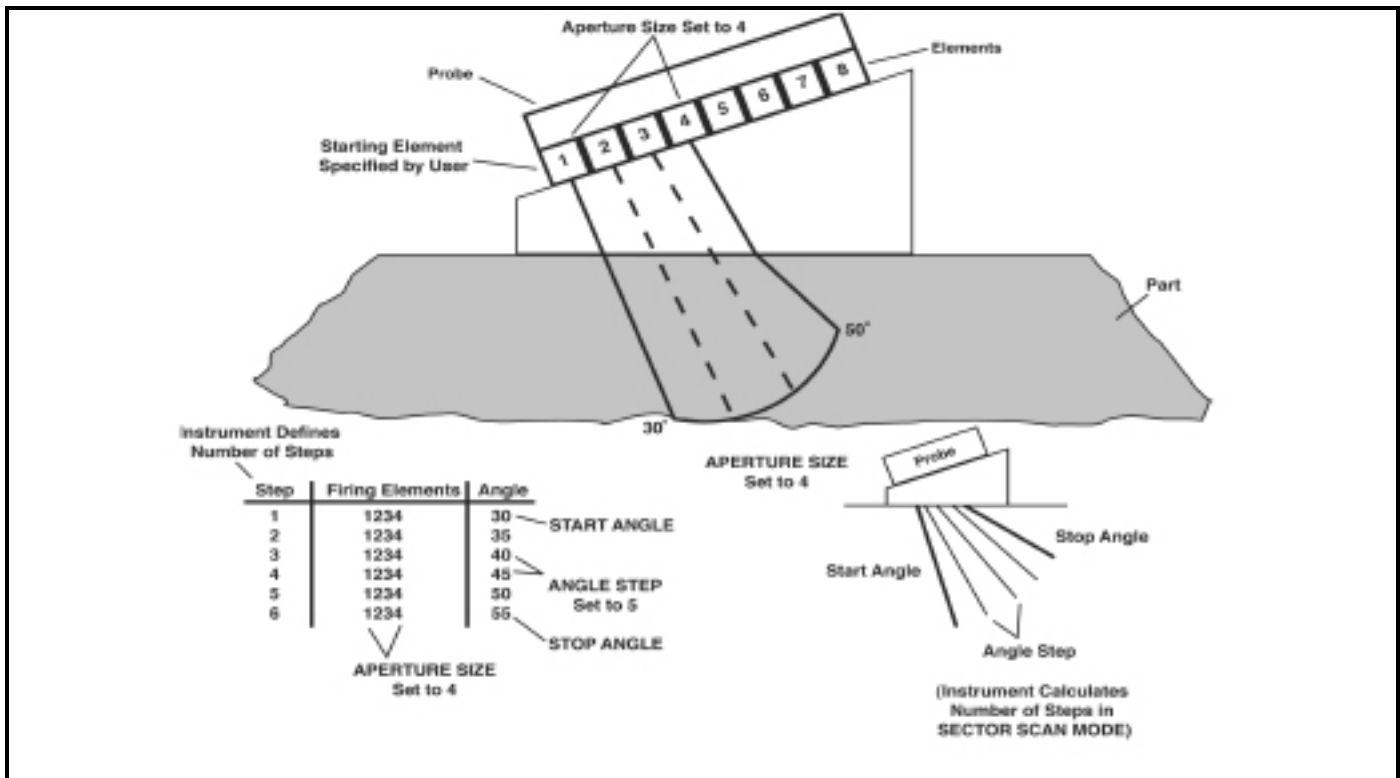

Figure 13: Sector Scan Parameters

2.5 Defining the Scan Parameters (cont.)

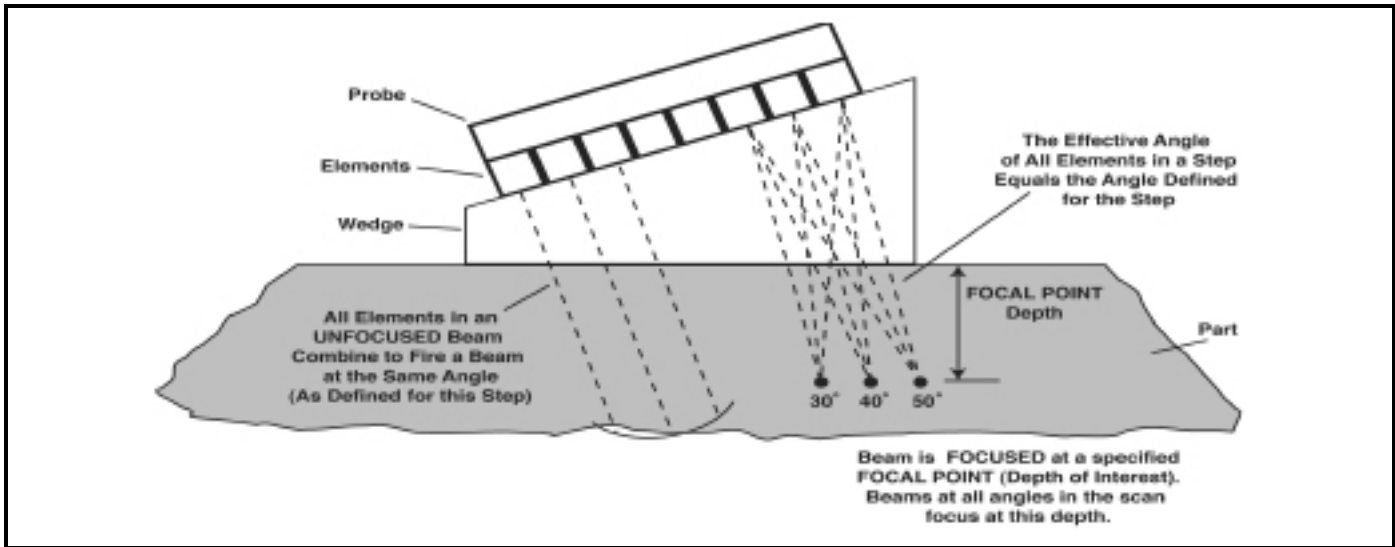

Figure 14: Sector Focal Point

WAVE TYPE – Indicates whether the user-input transverse or longitudinal speed of sound should be used. The setting selected will depend on the probe type or the type of wave created by refraction when using a wedge.

SCAN PATTERN – Start, stop, and step angles that define the incremental angular change followed during a sector scan. When performing a linear scan, the scanning angle remains constant at the value defined by **ANGLE START**.

*Note: A +/- Sector can be created by setting the sector scan's **START ANGLE** to a negative value and the scan's **END ANGLE** to a positive value.*



APERTURE – During a sector scan, these parameters define the first element to be fired and the number of additional elements to fire at each angular setting (or **STEP**). When performing a linear scan, the first element to be fired and number of additional elements in that **STEP** are defined, as well as the total number of steps.

ANGULAR CORRECTED VIEW – Adjusts the display to match the actual shape of the material inspected during the sector scan.

2.6 Defining the Ultrasonic Characteristics of the Displayed Scan



2.6.1 LEG Setting to Control the Scan Range

The displayed sector or linear scan represents the reflection of sound off various features in the test piece. The display range (distance traveled by the sound beam in the test piece) is altered by adjusting the LEG setting. The effect of this adjustment is to show fewer (or additional) legs as shown in Figure 15 below. To modify the LEG setting,

1. Make sure the COLOR LEG function (DISPLAY Menu, BACKGRND Submenu) is set to ON. This causes the leg lines shown in Figure 15 below to be displayed but is not otherwise required to use the LEG feature.
2. Press  to activate the HOME Menu. Then press  next to the selection titled LEG.
3. Turning the function knob will change the value of LEG and reduce or expand the sound-path length displayed on the screen. If COLOR LEG is set to ON, you'll also notice the addition or removal of leg lines as the LEG setting changes.

2.6.2 Setting the Display Delay

The DISPLAY DELAY function shifts the displayed scan to ignore (or show) a portion of the scan. This function is used to set the instrument's viewing window. To set the display delay

1. Activate the BASE Submenu (located in the UT Menu) by pressing  below it.
2. Press  next to the function titled DISPLAY DELAY. Change the value of the delay by turning the Function Knob, then press and hold  for three seconds to recalculate the delay laws. You'll note that the displayed Sector, Linear, or A Scan shifts in response to the setting change.

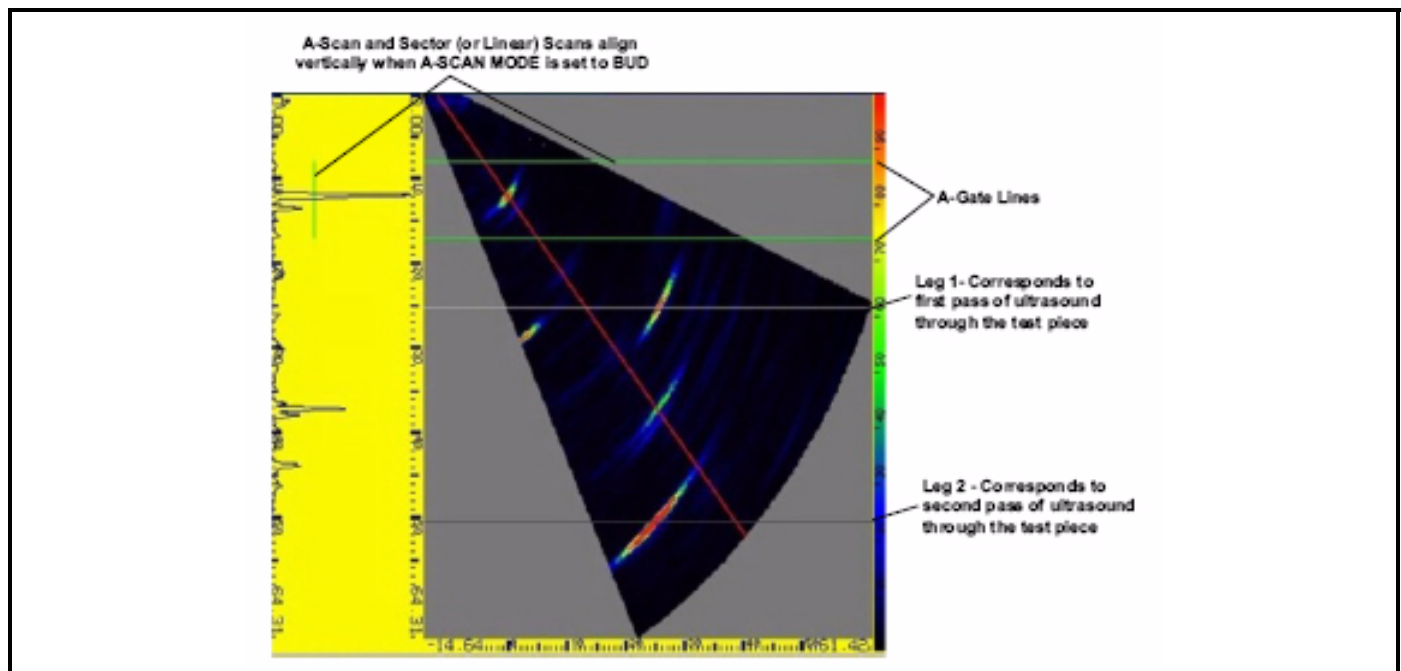





Figure 15: Changing the number of displayed LEGs modifies the displayed sound-path range. In this case, approximately 2.5 legs are displayed here.

2.6.3 Defining the Display's Starting Point

The DISPLAY START Function sets the display's starting point to match the initial pulse or IF-Gate trigger (for linear scans) or the position at which sound enters the test material (in all scans). To select a display starting position (Figure 16 below):

1. Activate the BASE Submenu (located in the UT Menu) by pressing  below it. The function can also be accessed via the SYNCH Submenu located in the SCAN Menu.
2. Press  next to the function titled DISPLAY START. Continue pressing  or turn the Function Knob to select from:
 - IP START—Display start corresponds to the initial pulse
 - IF START—Display start corresponds to the IF-Gate trigger
 - MATERIAL—Display start corresponds to the position at which sound enters the test material

Note: To select a DISPLAY START other than MATERIAL, the IF Gate must be turned ON. Initial IF Gate positioning is related to the Z parameter, which must not be set to zero (accessed via the WEDGE GEO Submenu, found in the PROBE Menu). The Z parameter relates to the measured distance from the probe to the test piece through the delay material. The IF Gate is initially positioned based on this value. Switching on the IF Gate activates the IF condition that controls the A- and B-Gate starting point.

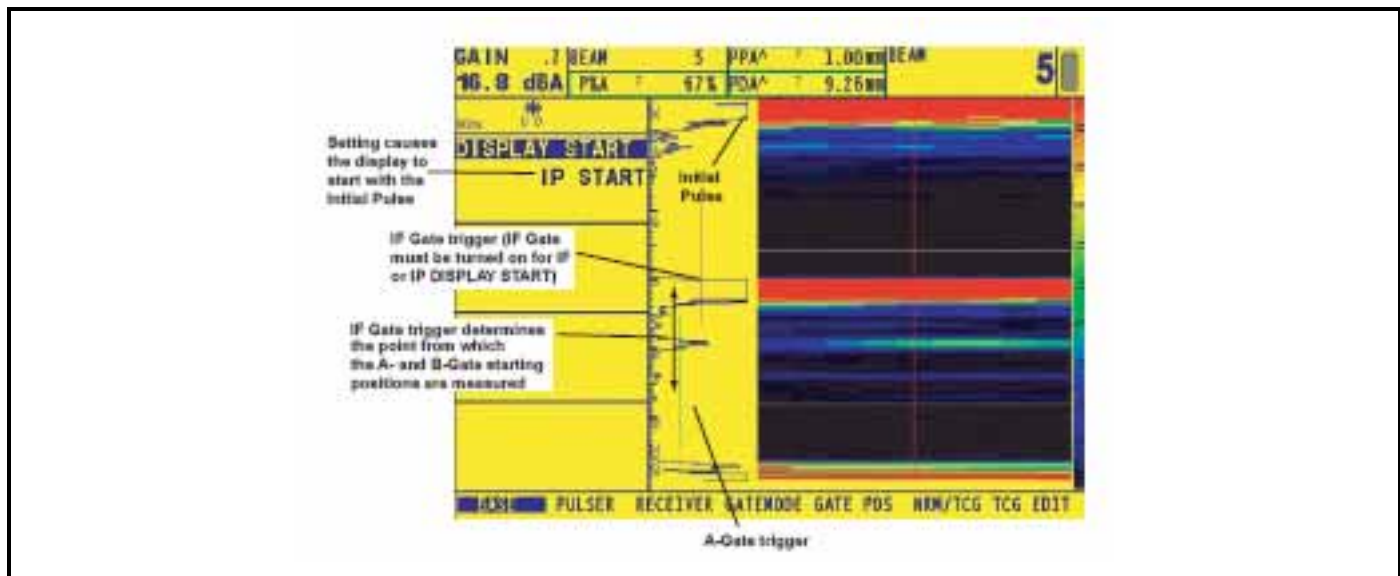



Figure 16: The DISPLAY START value can be set to IP, IF, or MATERIAL. When the IF Gate is turned on, the A- and B-Gate starting points are based on the IF-Gate triggering echo. Note that both IF and IP DISPLAY START modes accommodate variations in the initial-pulse-to-interface distance while the MATERIAL setting assumes a fixed distance from the initial pulse to the test-piece interface.

2.6.4 Setting the Encoder Direction (SCAN-SYNCH-ENC COUNT DIR)

The ENC COUNT DIR function directs the automated encoder system to use the designated scan direction. To set the function:

1. Activate the ENC COUNT DIR Submenu (via the SYNCH Submenu located in the SCAN Menu) by pressing  below it.
2. Two directional settings are available:
 - NORMAL (default value) indicates that the encoder counter should use the scan direction as the encoder is wired.
 - REVERSE indicates that the encoder counter should reverse the scan direction.



The parameter has no effect on timed top view and frame view scan. During frame view, timed top view and encoded top view scan, the user may change the parameter value. The parameter will be blocked if the instrument is in analysis (Freeze/stopped scan).

Note: During encoded scan, if the user changes the value of this parameter, the change will not take effect until the user starts a new scan. (The change has no effect on a resumed encoded scan.)

2.7 Pulser and Receiver Settings for Phased Array Operation

2.7.1 Setting the Pulser Voltage Level (UT-PULSER-VOLTAGE)

The relative energy with which the pulser fires is adjusted by changing the VOLTAGE setting. To set the pulser voltage level:

1. Activate the PULSER Submenu (located in the UT Menu) by pressing  below it. Functions will appear down the left side of the display screen.
2. Press  next to the function titled VOLTAGE. Note that the pulser VOLTAGE level can be set between 50 and 150 volts by turning the Function Knob.
3. The pulser VOLTAGE will be set to the value last displayed.

2.7.2 Selecting the Pulser Width (UT-PULSER-WIDTH)

The pulser width generally varies from 30 to 500 nanoseconds. The pulse width value is expressed as half of the bipolar squarewave pulse width. A recommended starting point from which the width setting can be adjusted is found by the following equation:



$$\text{PULSE WIDTH} = \frac{1000\text{ns}}{2f} \text{ with } f \text{ in MHz}$$

For example, if a 2 MHz probe is used, the equation becomes:



$$\text{PULSE WIDTH} = \frac{1000\text{ns}}{2 \cdot 2} = 250 \text{ nanoseconds}$$

$$\text{for } f = 2 \text{ MHz}$$

To set a pulser width:

1. Activate the PULSER Submenu (located in the UT Menu) by pressing  below it. Functions will appear down the left side of the display screen.
2. Press  next to the function titled WIDTH. Change the value by turning the Function Knob.
3. The pulser WIDTH will be set to the value last displayed.
4. Set the pulser repetition frequency (set in percent of maximum speed attainable by instrument settings)

2.7.3 Specifying the Receiver Frequency (UT-RECEIVER-FREQUENCY)

1. Activate the RECEIVER Submenu (located in the UT Menu) by pressing  below it. Functions will appear down the left side of the display screen.
2. Press  next to the function titled FREQUENCY. Change the value of the receiver frequency by continuing to press  or by turning the Function Knob. You'll note that the following frequency settings are available:
 - **2, 3, 4, 5 MHz**—Select as required
 - **LOW PASS 4 MHz**—Select to utilize a built-in lowpass (LP) filter
 - **HIGH PASS 5 MHz**—Select to utilize a built-in highpass (HP) filter
 - **BB 0.6–6.5 MHz**—Select to utilize a built-in broadband (BB) filter
3. The receiver frequency level will be set to the last selection displayed.

2.7.4 Selecting a Rectification Mode (UT-RECEIVER-ASCAN RECTIFY)



Rectification choice affects the display of the A-scan and the image on the display screen. Four rectification modes are supported in the Phasor XS™.

Radio Frequency (RF) signal has a negative component below the axis, and a positive component above the axis. In RF mode, the A-gate and B-gate can be positioned either above or below the axis, to be triggered by a positive-heading echo or a negative-heading echo. In the frame view image, both the negative and positive components are displayed.

Positive Half Rectification means that only the upper (positive) half of the RF signal is displayed. In the frame view image, only the positive component is displayed.

Negative Half Rectification means that only the bottom (negative) half of the RF signal is displayed. In the frame view image, only the negative component is displayed (Figure 17 on page 38).

Full-Wave Rectification combines the positive and negative rectified signals together, and displays both of them in a positive orientation. In the frame view image, both the negative and positive components are displayed (Figure 18 on page 38). Use the following procedure to select a rectification mode:

1. Activate the RECEIVER Submenu (located in the UT Menu) by pressing  below it. Functions will appear down the left side of the display screen.
2. Press  next to the function titled ASCAN RECTIFY to select rectification method. You'll note that there are four options:
 - **NEG HALFWAVE**—Shows the negative component of the RF signal but displays it in a positive orientation
 - **POS HALFWAVE**—Shows the positive component of the RF signal
 - **FULLWAVE**—Shows the positive and negative halves of the RF wave, but both are oriented in the positive direction
 - **RF**—Shows the echo with no rectification

2.7.4 Selecting a Rectification Mode (UT-RECEIVER-ASCAN RECTIFY) (cont.)

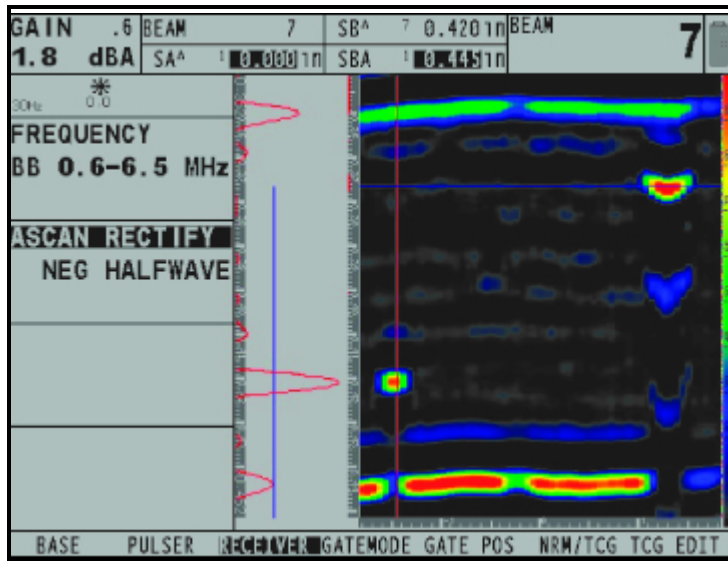

Figure 17: Image with negative rectification

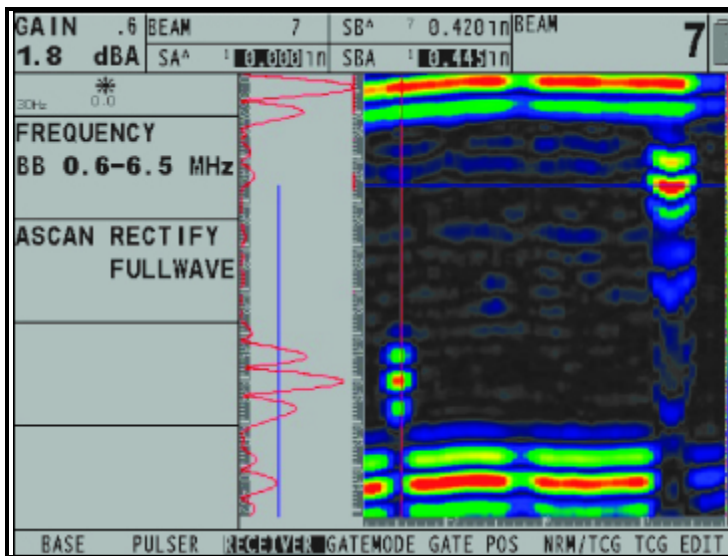

Figure 18: Image with fullwave rectification

2.8 Managing Gates for Phased Array Operation

Setting the position and characteristics of the IF, A, and B-Gates for phased-array operation requires access to the UT Menu. The GATEMODE and GATE POS menus control not only the location of the gates but also the alarms and other features activated when an A-Scan is triggered.

Note: With a sector scan displayed, gate width and starting position are measured (and displayed) with respect to material depth (not sound-path depth). Material depth is measured perpendicular to the test piece's contact surface for all angles in the scan.

2.8.1 Positioning Gates

Use the following procedures to set the position of the IF, A, and B-Gates. The effect of each gate-positioning function is shown in Figure 19 below.

Remember that gate position has the following effects on instrument performance:

- The IF Gate provides a reference point from which the other gates are positioned, and provides a reference from which the displayed data can be positioned. No data is collected from IF-Gate triggering. The range of values that can be input for the starting point and width of the IF Gate is influenced by the Z parameter accessed via the WEDGE GEO Submenu, found in the PROBE Menu.
- The A-Scan displays echo amplitudes as a function of distance for all reflected sound waves. When the gate is moved down (as shown in Figure 19), the gated area represents a region that's deeper into the test material.
- A wider gate will simply span the equivalent of more test-material depth.
- Increasing the threshold of a gate means that only reflected signals of sufficiently large amplitude will cross the gate.

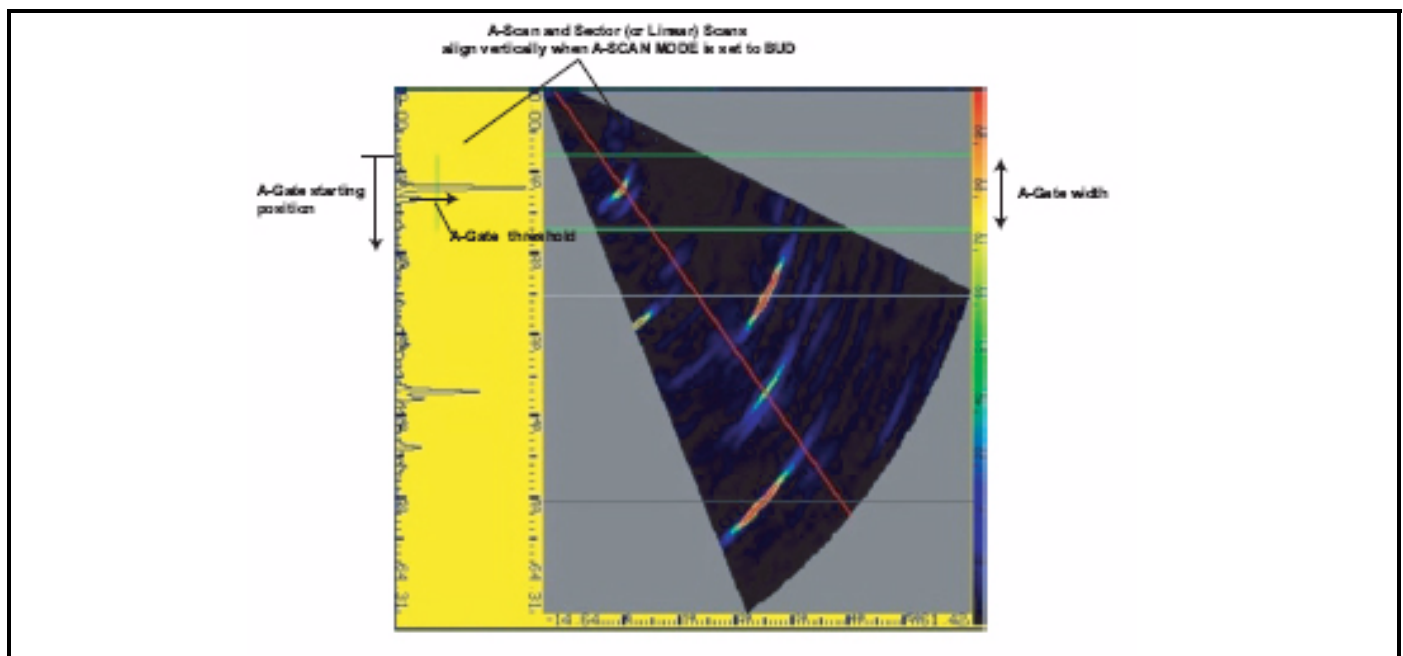

Figure 19: Gate position and width can be adjusted as shown here.

2.8.1 Positioning Gates (cont.)

Note: A- and B-Gates can be removed from the active display by using the GATE DISPLAY Function. When removed from the display in this manner, the gate continues to function. The IF Gate's GATE LOGIC setting can be turned to OFF, disabling the gate and removing it from the display. Otherwise, the IF Gate will always be displayed with turned on.

Note: Gate starting point and width can be adjusted from the HOME Menu's function bar. To control IF, A, or B-Gate from this menu, first select the desired gate using the GATE SELECT Function (accessed via the GATEMODE or GATE POS Submenus). The color of the text in the gate-controlling function box will match the color of the selected gate.

Note: The IF Gate provides a reference point from which the other gates are positioned. The A- and B-Gate starting positions are measured with respect to IF-Gate trigger whenever the IF-Gate is turned "on" (meaning its logic setting is set to POSITIVE). See also Section 2.6.3.

Note: When operating with the DISPLAY START Function set to IF, the interface echoes for each beam are visible on the display. This provides a visual indication of variation in the IF-Gate triggering point. When operating in this mode only, the operator is alerted to the loss of an IF-Gate triggering echo by the application of a special IF LOSS color to the display.

Setting a Gate's Starting Point (UT-GATE POS-GATE START)

1. Activate the GATE POS Submenu (located in the UT Menu).
2. Select the gate to be positioned using the GATE SELECT function. The color of function-block values matches the color of the corresponding gate.
3. Select the GATE START function and adjust the starting point by turning the Function Knob. Increasing and decreasing the value of the starting point moves the gate (in A-Scan view) to the right and left, respectively.
4. The gate starting point will remain as set, even when width adjustments are made.

Adjusting a Gate's Width (UT-GATE POS-GATE WIDTH)

1. Activate the GATE POS Submenu (located in the UT Menu).
2. Select the gate to be positioned using the GATE SELECT function.
3. Select the GATE WIDTH function and adjust by turning the Function Knob.

Setting a Gate's Threshold (UT-GATE POS-GATE THRESHOLD)

1. Activate the GATE POS Submenu (located in the UT Menu).
2. Select the gate to be positioned using the GATE SELECT function.
3. Select the GATE THRESHOLD function and adjust the vertical height by turning the Function Knob. Increasing and decreasing the value of the threshold moves the gate (in A-Scan view) up and down, respectively.

Hiding an Active Gate from the Display (UT-GATE POS-GATE DISPLAY)

An active A- or B-Gate (one whose LOGIC setting is not set to OFF) can be hidden from the display while continuing to function. To hide a gate from the display:

1. Active the GATE POS Submenu (located in the UT Menu)
2. Select the gate to be hidden using the GATE SELECT function.
3. Set the value of GATE DISPLAY to OFF. The gate will continue to function but will no longer be displayed.

2.8.2 Selecting the TOF-Detection Method

A-Scan signals crossing a gate are evaluated for the purposes of flaw detection and material-thickness. When the signal crosses the A or B-Gate, either the gate-crossing point (flank) of the signal, or the maximum point (peak) of the signal (in the specific gate) is used for evaluation purposes. The TOF MODE function allows the user to specify which A-Scan feature (FLANK or PEAK) is used to evaluate the signal in the A and B Gates.

1. Activate the GATEMODE Submenu (located in the UT Menu).
2. Select the gate to be positioned using the GATE SELECT function.
3. Select the TOF MODE function and choose between FLANK and PEAK methods.

Note: The detection method chosen will be reflected by the / (flank) or ^ (peak) icons. These icons are displayed in the display box containing the measured reading, and in the options offered in the READING 1 through 4 function boxes.

2.8.3 Setting Gate Logic

A TTL output can be set to transmit whenever a user-selected gate triggers. When a gate-triggering event occurs, an alarm indication light on the front of the instrument will illuminate and a signal can be output.

Defining Gate-Triggering Logic (UT-GATEMODE-LOGIC)



The A, B, and IF Gates can be triggered under one of two circumstances. Gates can be set to trigger when an A-Scan echo crosses the gate or when no echo crosses the gate. To specify gate LOGIC settings:

1. Activate the GATEMODE Submenu (located in the UT Menu).
2. Select the gate to be modified using the GATE SELECT function.
3. Select the LOGIC function and choose the gate triggering logic:
 - POSITIVE—An A-Scan signal crosses the gate
 - NEGATIVE—No A-Scan signal crosses the gate (A and B Gates only)
 - OFF—The selected gate will not be triggered

Note: The IF Gate must be turned OFF for the instrument to produce a sector scan.

2.8.4 Configure the Gate to Ignore or Accept Off-Screen Triggers (DISPLAYRESULTS2-GATE SHAPE)

Gate triggering can, in some cases, occur at a point that does not appear in the display (A-scans or image). The GATE SHAPE Function determines whether or not A- or B-Gate triggers outside the display range are ignored. To configure the gate shape:

1. Activate the RESULTS2 Submenu (located in the DISPLAY Menu) by pressing  below it.
2. Press  next to the function titled GATE SHAPE. Continue pressing  or turn the Function Knob to select from:
 - **DEPTH BASED** – Each beam's gate range is set to the depth range specified by the GATE START and GATE WIDTH controls. All gate triggers within that range, including those that occur outside the display range, are valid. This is the default setting following an instrument reset. See Figure 20a below.
 - **IMAGE BASED** – Each beam's gate range is limited to its display range. Gate triggers that occur outside of the display range are ignored. See Figure 20b below.

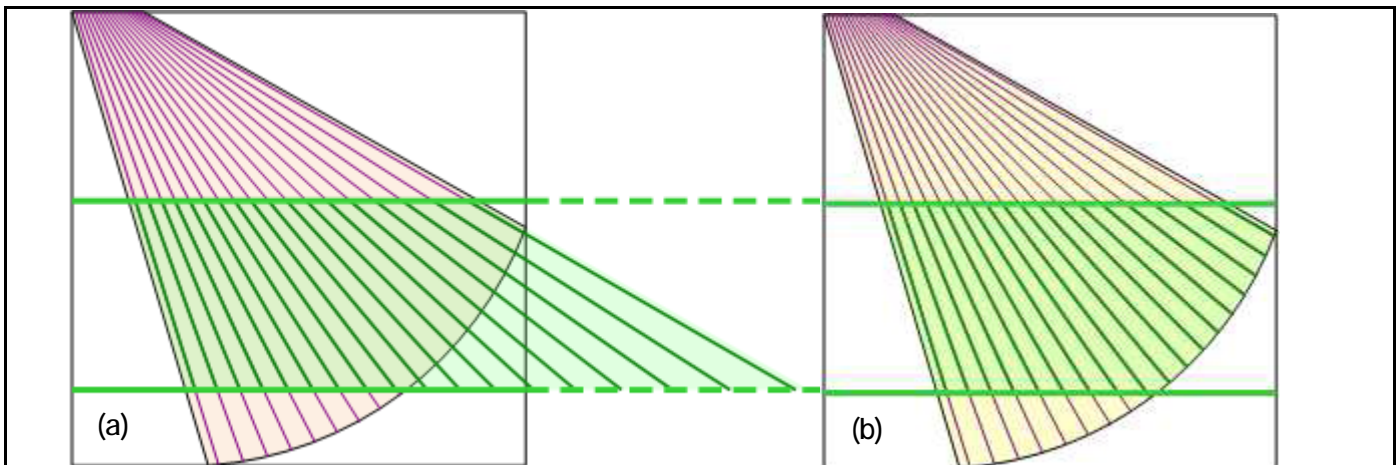

Figure 20: Depth-Based (a) and Image-Based (b) Gate Shapes

Note: When gate width, leg setting, or other parameters are configured so that the A or B gate does not appear on the display screen, changing the GATE SHAPE setting to IMAGE BASED automatically adjusts (snaps) the gate start and gate width, if required, to keep the gate visible on the display screen.

2.8.5 Assign TTL Output / Alarm Indication Light to a Gate (DISPLAY-RESULTS2-TTL #1)

A warning light appears on the front of the instrument (see Figure 2 on page 2 for light location). This light corresponds to a TTL output, which occurs when there is a gate triggering event. When the A- or B-Gate is triggered, a warning light illuminates (except when the GATE LOGIC is set to OFF). Use the following procedure to indicate which gate activates the light:



1. Activate the RESULTS2 Submenu (located in the DISPLAY Menu).
2. Activate the TTL #1 function and choose one of the following selections:
 - A-GATE—Alarm light indicates when A-Gate triggers
 - B-GATE—Alarm light indicates when B-Gate triggers
 - A or B—Alarm light indicates when either A or B gate triggers
 - OFF—Alarm indication light will not function

2.9 Calibrating the Instrument/Probe Combination

The phased-array calibration process requires the use of a calibration standard, of proper material type, with two known reflectors. Completing the process requires adjustment of the PROBE DELAY and VELOCITY values to match the instrument/probe/test piece combination in use. Before launching the calibration process, complete all applicable tasks described in Chapters 2 and 3, including:

- Inputting the Probe and Wedge characteristics
- Define the scan
- Input Material Type
- Input Ultrasonic settings
- Configure the RESULTS displayed to include SBA, SA, and BEAM Angle.
- Position the A and B Gates to capture the two known reflectors on the calibration standard (capture the deeper reflector with the B-Gate). Set Gate Detection Logic to POSITIVE. Be sure IF GATE LOGIC is set to OFF.
- Move the BEAM CURSOR to select the “nominal” effective angle of the probe wedge, which is the refraction angle in the test object based on the given wedge angle (Snell’s Law).

To launch the calibration process:

1. Activate the CAL Submenu (Located in the PART MENU) by pressing  below it. Selections will appear down the left side of the display.
2. Couple the probe to the calibration standard so that the first reflector is captured in A-Gate and the second (deeper) reflector is captured by the B-Gate. Press  next to VELOCITY and adjust the value until the displayed SBA value matches the depth of the calibration standard’s known reflector.
3. Couple the probe to the calibration standard so that the first reflector is captured in A-Gate. Press  next to PROBE DELAY and adjust the value until the displayed SA value matches the depth of the calibration standard’s known reflector.

The material velocity and probe delay are now adjusted to match the instrument/probe/test piece combination.

2.9.1 Performing a Quick Calibration

Using the optional calibration block purchased with your instrument (or one you've fabricated), a quick calibration procedure (matched to a designated sector-scan application) can be performed as follows:

Setup Procedure

1. Press  to display the A-Scan-plus-Sector Scan view.
2. Use the BEAM CURSOR to select the desired reference A-Scan (such as 45 degrees). Beam cursor is controlled via the CAL submenu in the PART menu.
3. Adjust the LEG setting (HOME menu) to move the displayed cal-block reflectors to screen positions corresponding to 1 and 4 inches (25 and 100 mm for the equivalent EN calibration block).
4. Display and position the A-Gate (using the GATEMODE and GATE POS submenus located in the UT menu) to detect the first cal-block reflector. Be sure the IF GATE LOGIC is set to OFF.
5. Display and position the B-Gate (using the GATEMODE and GATE POS submenus located in the UT menu) to detect the second cal-block reflector.
6. Adjust gate detection mode to PEAK or FLANK as required by your calibration procedure.
7. Display SA and SBA measurements (accessed via the RESULTS1 submenu located in the DISPLAY menu).
8. Adjust the probe position to maximize the echo amplitude.
9. Adjust instrument gain to move the largest displayed echo to just below 100% FSH.

Calibration Procedure

1. Access the CAL submenu located in the PART menu.
2. Adjust the VELOCITY setting until the displayed SBA measures 3 inches (or 75 mm if an EN block is used)
3. Adjust the PROBE DELAY setting until the displayed SA measures 1 inch (or 25 mm if an EN block is used)
4. Recalculate the delay laws by pressing and holding  for three seconds.

2.9 Performing a Quick Calibration (cont.)

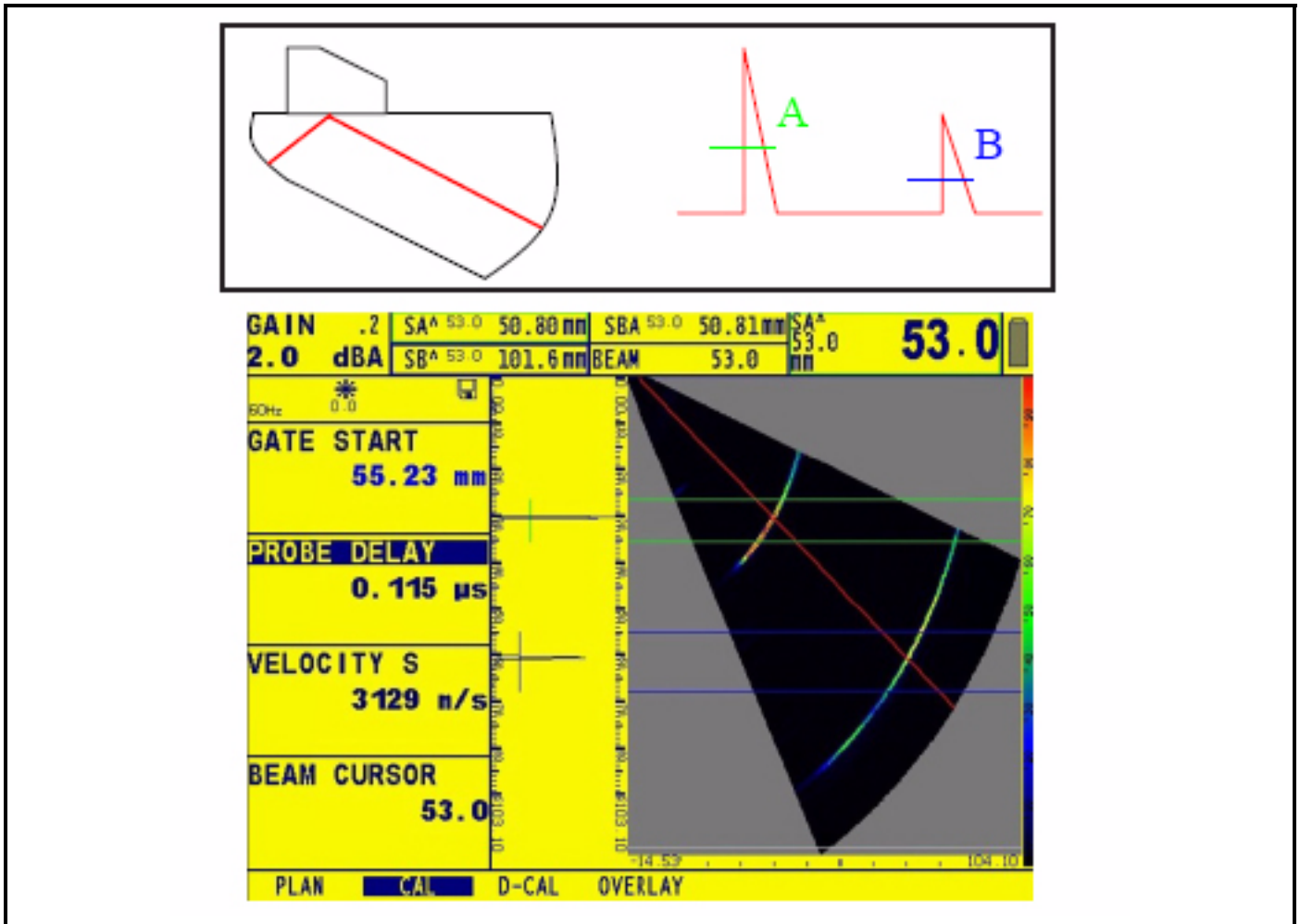

Figure 21: Calibration shown using an IIW block with 2" and 4" radius

2.9.1 Depth Cal

All distance based results for gates A and B can be displayed taking into account a depth calibration correction. Depth calibration is specified by the first or second point in a reference menu.

The Phasor XS supports two modes of depth calibration. Recording of depth calibration references requires entering the values in the D-CAL menu. Depth calibration is best performed using side-drilled holes in a calibration standard.

One-Point calibration used a reference echo recorded on each beam of the scan to calculate a delay time that will allow the instrument to display the same depth distance for the reference reflector on every beam.

Two-Point calibration uses two reference echoes recorded at different depth on each beam of the scan to calculate a delay time and velocity that will allow the instrument to display the same depth distances for the reference reflectors on every beam.

Depth calibration mode’s effect on result readings is indicated by the depth calibration icon displayed in the icon window.

The D-CAL menu includes:

- GATE START — Adjust the start position of Gate A
- 1-POINT — Select to start a 1-point D-CAL (only calibrates probe delay for each beam)
- 2-POINT — Select to start a 2-point D-CAL (calibrates the material velocity and each beam’s probe delay)

Throughout the process, GATE START allows users to adjust the gate position for each reference point. The instrument uses Gate A and will automatically change the selected gate and set the detection mode as needed. Once finished, the Phasor XS will reset the Gate A detect mode and reset the selected gate.

Choose 1-POINT or 2-POINT to begin the respective depth calibration record process. The D-CAL menu will transition through the following steps.

For 1-point calibration:

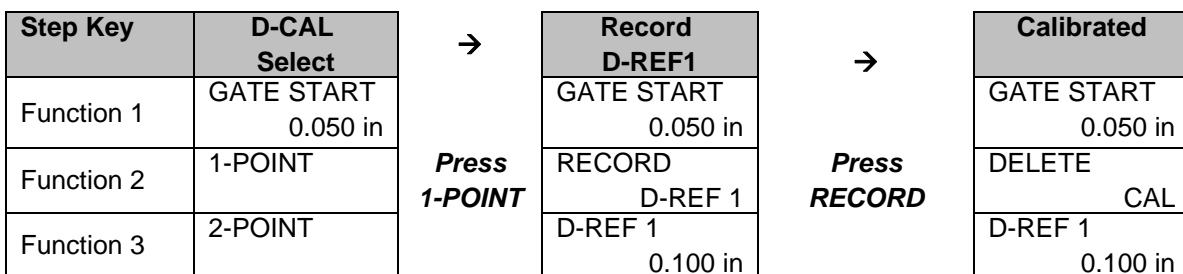

2.9.1 Depth Cal (cont.)

For 2-point calibration:

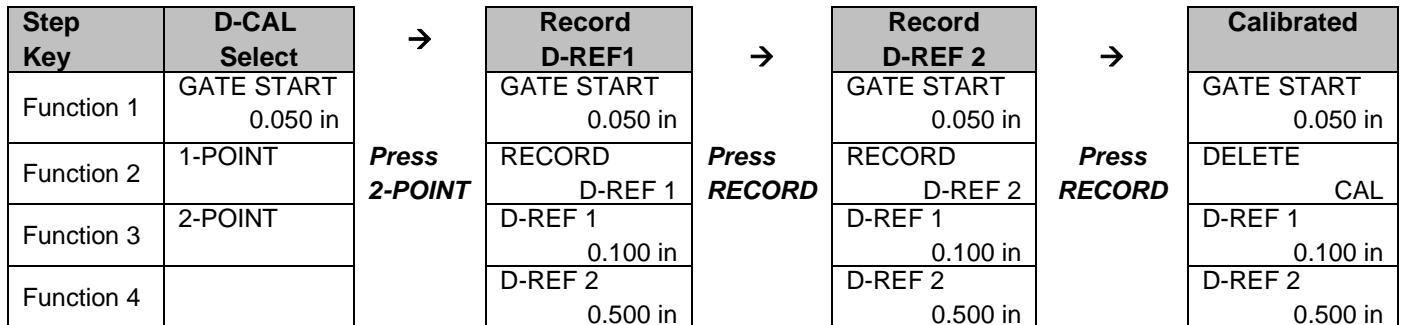

At the step D-CAL Select, choose which depth calibration to use:

- 1-POINT - only calibrates probe delay
- 2-POINT - calibrates the material velocity and probe delay

To choose and start the calibration process, press the key beside the desired calibration type.

Note: As with other key entries, the user must press the key twice, once to select and once to execute the action.

During the Record steps, the instrument displays the current reference point in the RECORD parameter. Set the reference point depth in the respective D-REF 1 or D-REF 2 parameter field. For a 2-point calibration, the D-REF 1 depth must be less than D-REF 2. The instrument displays the amplitude map window (shown in Figure 22 below) to show the amplitude values of each beam.

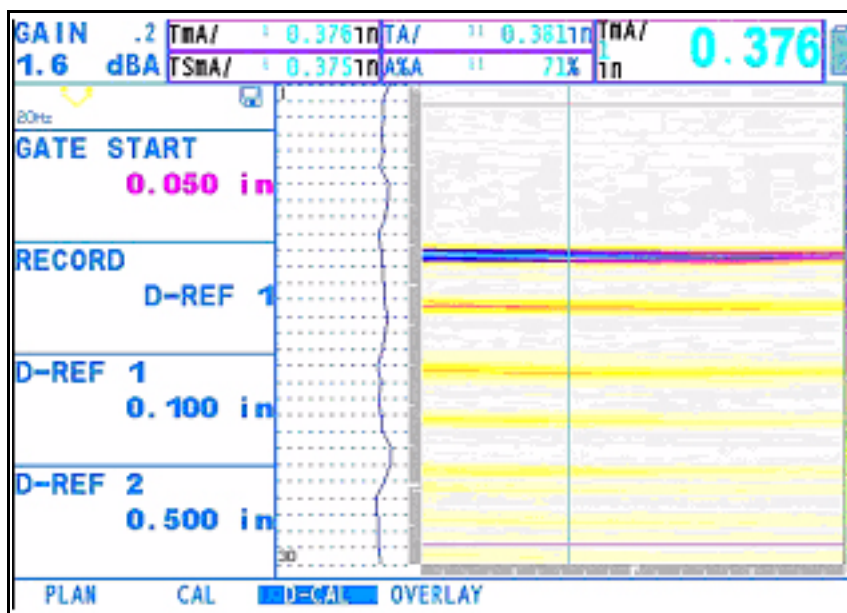

Figure 22: Depth Calibration Recording

2.9.1 Depth Cal (cont.)

Press RECORD to transition to the Record D-REF 2 step (2-Point only) or the final Calibrated step. Pressing and holding the RECORD parameter (for 3 seconds) will cancel the current step and return to the previous step.

If a problem occurs during the record process, the instrument will block the record and display the cause of the problem. Examples are:

- TOF Not Detected - no echo in the gate to evaluate the time-of-flight (depth) of the echo.
- Invalid TOF Difference - the second point's TOF must be greater than point 1.

Once calibrated, the reference points are locked. To change the reference points, the user must delete the calibration references.

Note: The D-CAL MODE is used internally to support previous version POP files and manage the record state.

To delete the calibration, press DELETE CAL in the D-CAL menu. If pressed, display the following message to confirm the delete:

PRESS HOME TO CONFIRM DELETE CAL

If the user presses the HOME key to confirm the deletion, the instrument deletes the references and returns the instrument to the D-CAL Select step. The instrument will cancel the delete action after 5 seconds of no key input or if the user presses any key other than the HOME key.

2.9.1a Auto-Zero After Finish

After the user finishes the depth calibration, the instrument will apply the calibrated delay to each beam's display delay, in addition to the global PROBE DELAY, in order to correct the image to the top of the image area.

Note: After one-point calibration, the Phasor XS updates PROBE DELAY to PROBE DELAY plus calibration delay minus the minimum (of all beams) wedge delay (including physical wedge delay and virtual wedge delay).

Note: After two-point calibration, the instrument automatically sets
— *The velocity, for the selected WAVE TYPE, to the calibrated velocity.*
— *MATERIAL to the "CUSTOM" selection.*
— *PROBE DELAY to the average calibrated delay. Each beam will also have a delay adjustment to compensate for minor variations in the probe face or wedge.*

Note: TCG and Depth calibration modes operate independently. TCG may have up to 16 points, recorded in any order.

2.10 Optional Graphic Overlay

The graphic overlay feature allows the user to use preset or custom overlays while viewing an angle corrected linear or sector scan image. The overlay control parameters are located in the OVERLAY submenu of the PART menu. A press of the DEFINITION parameter  will display the definition wizard. A drawing is displayed in the overlay wizard that illustrates each overlay's dimensions.

The overlay image is linked to the position of the origin line. Moving the origin line will move the overlay on the image. The OVERLAY DISPLAY parameter is used to display or hide the overlay once it has been defined. There are four preset overlay types and one custom overlay. The following preset overlays are supported:

Table 1: Preset Graphic Overlay Types

Value	Description
Single V	V type weld preparation, centered around the origin line
Double V	X type weld preparation, centered around the origin line
Ref. Line	A simple reference line that may be used to define a boundary or other region
Rectangle	A rectangle object use to outline a region of the image

2.10 Optional Graphic Overlay (cont.)

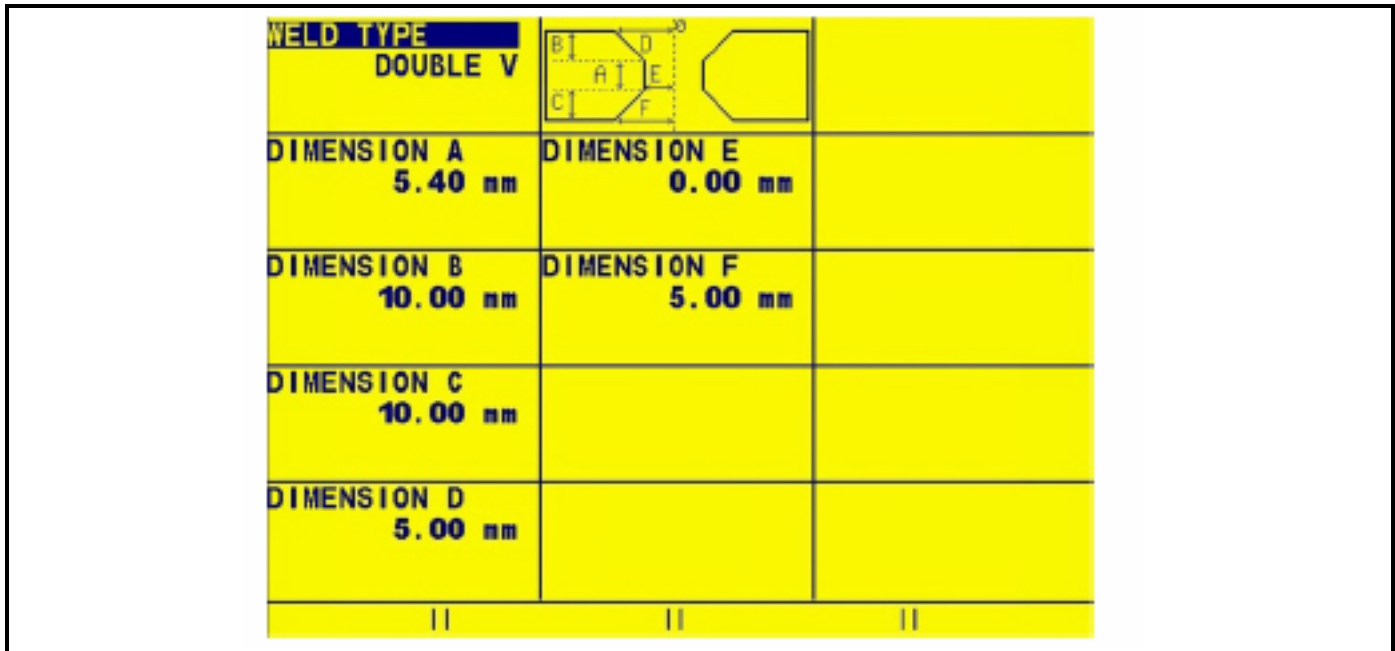



Figure 23: Graphic Overlay Wizard

To select and set up an overlay:

1. Setup the desired scan according to the test being performed.
2. Navigate to the PART - OVERLAY sub-menu and select DEFINITION twice. The overlay wizard menu will be displayed.
3. Select the desired overlay type with the WELD TYPE parameter. The  is used to select the first row of parameter options.
4. Using the dimensioned drawing that is displayed as a reference set each of the dimension parameters to describe the part or region being inspected.
5. Once all dimensions have been set properly, press the  button to exit the overlay wizard and activate the overlay on the image.
6. The position of the overlay may be moved on the image by adjusting the position of the origin offset.

Note: The overlay will be hidden when a law calculation is pending or when angle correction is off.

Note: Custom overlays may be generated on a PC and loaded into the Phasor XS using the LOAD OVERLAY action in the file menu. Activate the CUSTOM overlay by setting the WELD TYPE to CUSTOM. The user cannot set any dimensions for a custom overlay. Contact your support representative for more information on creating custom overlays.

2.10 Optional Graphic Overlay (cont.)

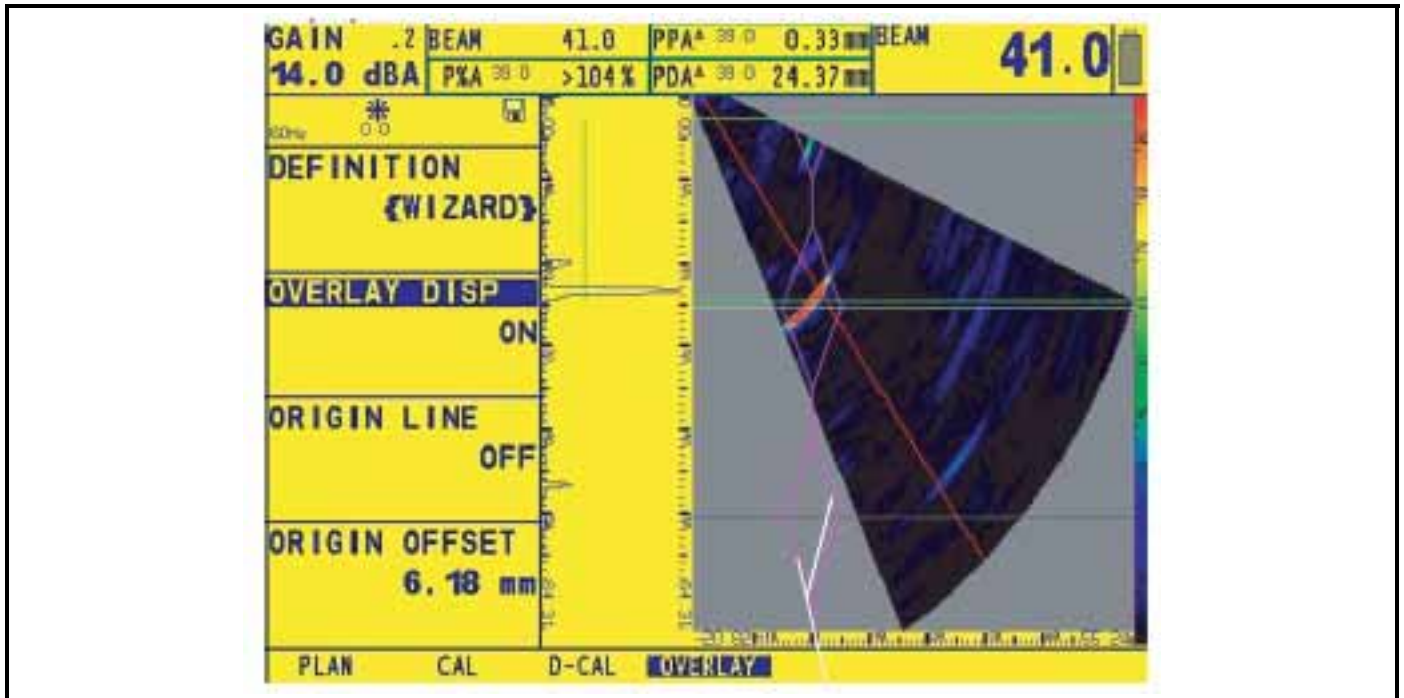



Figure 24: Example of a Double V Graphic Overlay

Chapter 3. Operating in Phased Array Mode

This chapter of the manual explains how to adjust the instrument's display to most effectively evaluate A, Sector, and Linear Scans acquired in Phased Array Mode. In this chapter, you'll learn how to:

- Set the displayed view to include either A-Scan, Sector (or Linear) Scan, or a combination of the two (Section 3.1)
- Select the measured values to be displayed (Section 3.2)
- Link and Unlink the A-Scan's position with the Sector or Linear Scan when both are displayed (Section 3.3)
- Control the Beam Cursor's Angular Position with the Function Knob (Section 3.3)
- Assess on-screen images in Freeze Mode (Section 3.4)
- Adjusting the gain setting (Section 3.6)
- Operate in TCG Mode (Section 3.7)

3.1 Selecting the Displayed View (Phased Array)

When operating in Phased Array Mode, there are three ways in which the resulting image may be viewed. Press  to change the view mode, noting that each change requires a few seconds to update the display screen. During this brief

delay,  appears near the upper right corner of the screen. If the A-Scan and Sector (or Linear) Scans are displayed simultaneously, the relation of the two scans with respect to each other can be modified as described in Section 3.3. Available views include:

- Sector or Linear Scan only (Figure 25 on page 54)
- Sector or Linear Scan with A-Scan (Figure 26 on page 54)
- A-Scan only

As described in Section 2.5, switching between Sector and Linear Scans requires recalculation of the phased-array delay laws. If a change is required, access the ELECTRNC Submenu (in the SCAN Menu) and choose the TYPE of scan. Note that the IF Gate's LOGIC Function must be set to OFF before selecting a sector scan type.

3.2 Displaying Results (Phased Array)

The instrument display screen contains reading boxes in which it displays up to four measured readings at one time. Each window shows the measured value, its identifying label (such as A%A) and, in smaller digits, the number of the beam in which it occurred. Measured values available for display include the following (availability depends on instrument configuration and operating mode):

Note: The ^ symbol indicates that GATE detection mode is set to PEAK while / indicates it is set to FLANK. All measurements are relative to the origin line.

In non-English language Phasor software, the reading references remain in English rather than the translated software.

Gate triggering can, in some cases, occur at a point that does not appear on the display screen. Setting the GATE SHAPE Function to DEPTH BASED ensures that off-screen triggers of the A- or B-Gates are ignored. See Section 2.8.4.

3.2 Displaying Results (Phased Array) (cont.)

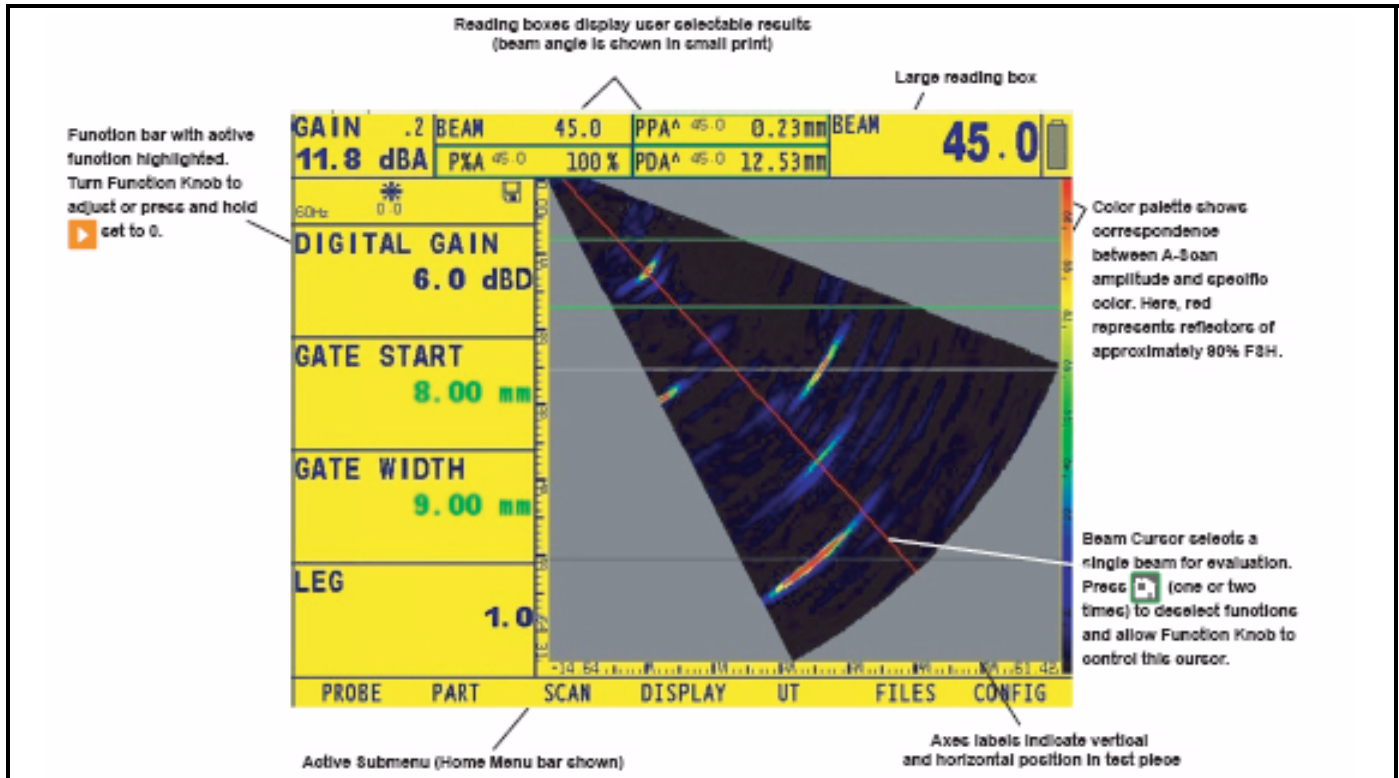

Figure 25: Either the Sector (shown here) or Linear Scan can be displayed by itself. Note key on-screen axes and other features identified here.

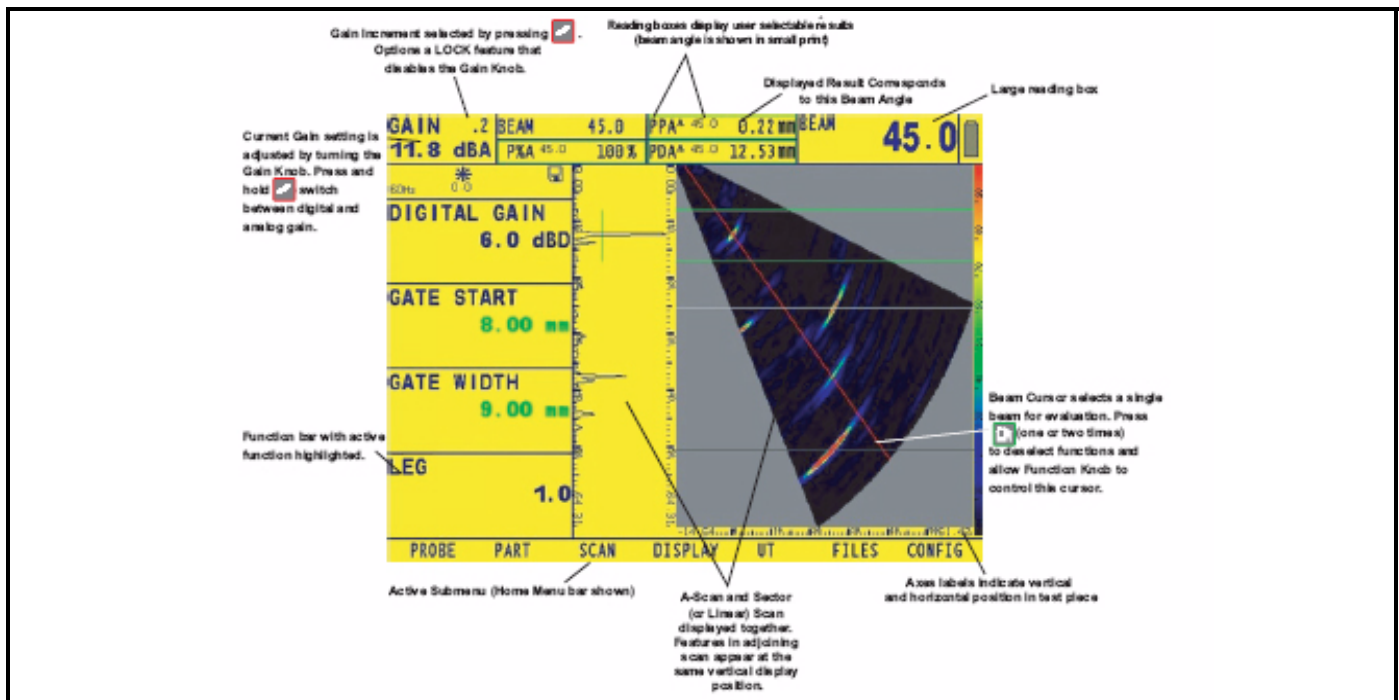

Figure 26: The A-Scan can be displayed (note its vertical orientation) together with either the Sector (shown) or Linear Scan.

GATE A – Readings for all beams

- P%A Peak amplitude captured by Gate A associated with the beam generating the PSA result (as a % of FSH).
- PSA^ Soundpath of the peak amplitude of all beams in scan that are currently captured by Gate A.
- PPA^ Projection distance from specified origin of the peak amplitude of all beams in scan that are currently captured by Gate A.
- PDA^ Volume corrected depth of the peak amplitude of all beams in scan that are currently captured by Gate A.
- PZA^ Uncorrected depth of the peak amplitude of all beams in scan that are currently captured by Gate A.
- PSA/ Soundpath of the first echo that crosses gate A threshold of all beams in scan.
- PPA/ Projection distance from specified origin of the first echo that crosses gate A threshold of all beams in scan.
- PDA/ Volume corrected depth of the first echo that crosses gate A threshold of all beams in scan.
- PZA/ Uncorrected depth of the first echo that crosses gate A threshold of all beams in scan.

GATE B – Readings for all beams

- P%B Peak amplitude captured by Gate B associated with the beam generating the PSB (as a % of FSH).
- PSB^ Soundpath of the peak amplitude of all beams in scan that are currently captured by Gate B.
- PPB^ Projection distance from specified origin of the peak amplitude of all beams in scan that are currently captured by Gate B.
- PDB^ Volume corrected depth of the peak amplitude of all beams in scan that are currently captured by Gate B.
- PZB^ Uncorrected depth of the peak amplitude of all beams in scan that are currently captured by Gate B.
- PSB/ Soundpath of the first echo that crosses gate B threshold of all beams in scan.
- PPB/ Projection distance from specified origin of the first echo that crosses gate B threshold of all beams in scan.
- PDB/ Volume corrected depth of the first echo that crosses gate B threshold of all beams in scan.
- PZB/ Uncorrected depth of the first echo that crosses gate B threshold of all beams in scan.

GATE A – Readings for selected beam

- A%A Amplitude (as a % of full-screen height) of the highest echo to cross A-Gate in the beam selected by the beam cursor.
- SA^ Soundpath represented by the highest echo to cross A-Gate in the beam selected by the beam cursor.
- PA^ Projection distance from specified origin to the reflector represented by the highest echo in A-Gate in the beam selected by the beam cursor. (see Figure 3-3)
- DA^ Volume corrected depth to the reflector represented by the highest echo in A-Gate in the beam selected by the beam cursor. (see Figure 3-3)
- ZA^ Uncorrected depth to the reflector represented by the highest echo in A-Gate in the beam selected by the beam cursor. (see Figure 3-3)

GATE A – Readings for selected beam (cont.)

- SA/ Soundpath of the first echo that crosses gate A threshold in the beam selected by the beam cursor.
- PA/ Projection distance from specified origin of the first echo that crosses gate A threshold in the beam selected by the beam cursor. (see Figure 3-3)
- DA/ Volume corrected depth of the first echo that crosses gate A threshold in the beam selected by the beam cursor. (see Figure 3-3)
- ZA/ Uncorrected depth of the first echo that crosses gate A threshold in the beam selected by the beam cursor. (see Figure 3-3)

GATE B – Readings for selected beam

- A%B Amplitude (as a % of full-screen height) of the highest echo to cross B-Gate in the beam selected by the beam cursor.
- SB^ Soundpath represented by the highest echo to cross B-Gate in the beam selected by the beam cursor.
- PB^ Projection distance from specified origin to the reflector represented by the highest echo in B-Gate in the beam selected by the beam cursor. (see Figure 3-3)
- DB^ Volume corrected depth to the reflector represented by the highest echo in B-Gate in the beam selected by the beam cursor. (see Figure 3-3)
- ZB^ Uncorrected depth to the reflector represented by the highest echo in B-Gate in the beam selected by the beam cursor. (see Figure 3-3)
- SB/ Soundpath of the first echo that crosses gate B threshold in the beam selected by the beam cursor.
- PB/ Projection distance from specified origin of the first echo that crosses gate B threshold in the beam selected by the beam cursor. (see Figure 3-3)
- DB/ Volume corrected depth of the first echo that crosses gate B threshold in the beam selected by the beam cursor. (see Figure 3-3)
- ZB/ Uncorrected depth of the first echo that crosses gate B threshold in the beam selected by the beam cursor. (see Figure 3-3)

Miscellaneous

- BEAM Angular position of the Beam Cursor in Sector View, or Beam number in Linear view.
- SBA Soundpath difference between the echoes in Gate A and Gate B in the beam selected by the beam cursor.
- A%I Amplitude (as a % of full-screen height) of the highest echo to cross I-Gate in the beam selected by the beam cursor.
- OFF No reading will be displayed in the reading box.

(For Custom Measurements Only)

Note: *The readings listed below are the only readings that properly calculate the thickness results. The other readings listed in Chapter 3 are invalid in the custom application.*

- A%A Amplitude (as a % of full-screen height) of the highest echo falling within the width of A-Gate
- A%B Amplitude (as a % of full-screen height) of the highest echo falling within the width of B-Gate

Note: *When S, D, P, or R readings are displayed, the Gate-Detection Mode (5.1.2) setting for the referenced gate (A or B) is indicated by a ^ (Peak Mode) or a / (Flank Mode).*

- TA Thickness in gate A for the selected beam.
- TB Thickness in gate B for the selected beam.
- TmA Minimum thickness found in gate A for the entire probe scan
- TmB Minimum thickness found in gate B for the entire probe scan
- TSmA Scan Minimum, minimum thickness found in gate A for the entire part scan
- TSmB Scan Minimum, minimum thickness found in gate B for the entire part scan
- TBA Absolute value of the difference between TB and TA for the selected beam.
- TmBA Absolute value of the min (TB – TA) for all beams in the probe scan.
- 1TA Cursor 1 thickness in gate A for the selected beam at the given scan position.
- 1TB Cursor 1 thickness in gate B for the selected beam at the given scan position.
- 2TA Cursor 2 thickness in gate A for the selected beam at the given scan position.
- 2TB Cursor 2 thickness in gate B for the selected beam at the given scan position
- 1TBA Cursor 1 (TB – TA)
- 2TBA Cursor 2 (TB – TA)
- 1TmBA Cursor 1 min (TB - TA) for all beams in probe scan
- 2TmBA Cursor 2 min (TB - TA) for all beams in probe scan
- 1A%A Cursor 1 Amplitude (as a % of full-screen height) of the highest echo falling within the width of A-Gate
- 2A%A Cursor 2 Amplitude (as a % of full-screen height) of the highest echo falling within the width of A-Gate
- 1A%B Cursor 1 Amplitude (as a % of full-screen height) of the highest echo falling within the width of B-Gate
- 2A%B Cursor 2 Amplitude (as a % of full-screen height) of the highest echo falling within the width of B-Gate
- 1TmA Cursor 1 Minimum thickness found in gate A for the entire probe scan
- 2TmA Cursor 2 Minimum thickness found in gate A for the entire probe scan

(For Custom Measurements Only — continued)

- 1TmB Cursor 1 Minimum thickness found in gate B for the entire probe scan
- 2TmB Cursor 2 Minimum thickness found in gate B for the entire probe scan
- OTA Percentage over gate A threshold for all samples in the Top View scan
- OTPA Percentage over gate A threshold for samples between position cursors
- OTCA Percentage over gate A threshold for samples between both position and beam cursors
- OTB Percentage over gate B threshold for all samples in the Top View scan
- OTPB Percentage over gate B threshold for samples between position cursors
- OTCB Percentage over gate B threshold for samples between both position and beam cursors
- B2B1 Distance between beams. Available for probe scans of straight beam (0-degree) linear scans. (If the user selects this reading and the probe scan is any other type (sector or angled-linear), the result will display dashes (“----”).)

Note: TBA will account for V-Path error correction of each gate result prior to calculating the thickness difference. TBA is available in Frame View Running & Top View Running. TmBA is available only in Frame View Analysis. 1TBA, 2TBA, 1TmBA, 2TmBA, B2B1 and the parameters starting in OT are available only in Top View Analysis.

- Clearing the TSmA can also be accomplished by displaying the test menu where “CLEAR” is displayed. (To clear TSmA manually, press this  key to get the TEST menu, and press CLEAR.)
- After STOP or FREEZE of Top View, the instrument automatically places the position of the Scan Minimum Thickness at the middle of the screen and the cursors snap to the position and beam of the Scan Minimum.

The four measured readings can be displayed in any of the four small reading boxes at the top of the display screen. In addition, the result displayed in one of the four small boxes can be shown in the large reading box (see Figure 26 on page 54). Also note that when time-of-flight or thickness readings are displayed, the detection method selected for that gate is indicated with a ^ (representing PEAK) or / (representing FLANK). See Section 2.8.2 to select detection methods.

(For Japanese JIS Results Only)

Note: The Japanese JIS code requires the use of the “W” and “Y” result prefix for sound path (“S”) and projection distance (“P”) results. The results will function the same (yield the same results) as their corresponding “S” and “P” results. The result window label should match the selected reading.

Conventional Channel

- WA—Gate A sound path (same as SA)
- YA—Gate A projection distance (same as PA)
- WB—Gate B sound path (same as SB)
- YB—Gate B projection distance (same as PB)

Phased Array

The following result labels are included in the READING 1 to 4 list for Frame View live and analysis (freeze mode) and Top View live:

GATE A – Readings for all beams

- PWA[^] Soundpath of the peak amplitude of all beams in scan that are currently captured by Gate A. (Same as PSA[^])
- PYA[^] Projection distance from specified origin of the peak amplitude of all beams in scan that are currently captured by Gate A. (Same as PYA[^])

GATE B – Readings for all beams

- PWB[^] Soundpath of the peak amplitude of all beams in scan that are currently captured by Gate B. (Same as PSB[^])
- PYB[^] Projection distance from specified origin of the peak amplitude of all beams in scan that are currently captured by Gate B. (Same as PPB[^])

GATE A – Readings for selected beam

- WA[^] Soundpath represented by the highest echo to cross A-Gate in the beam selected by the beam cursor. (Same as SA[^])
- YA[^] Projection distance from specified origin to the reflector represented by the highest echo in A-Gate in the beam selected by the beam cursor. (Same as PA[^])
- WA/ Soundpath of the first echo that crosses gate A threshold in the beam selected by the beam cursor. (Same as SA/)
- YA/ Projection distance from specified origin of the first echo that crosses gate A threshold in the beam selected by the beam cursor. (Same as PA/)

GATE B – Readings for selected beam



- WB[^] Soundpath represented by the highest echo to cross B-Gate in the beam selected by the beam cursor. (Same as SB[^])
- YB[^] Projection distance from specified origin to the reflector represented by the highest echo in B-Gate in the beam selected by the beam cursor. (Same as PB[^])
- WB/ Soundpath of the first echo that crosses gate B threshold in the beam selected by the beam cursor. (Same as SB/)
- YB/ Projection distance from specified origin of the first echo that crosses gate B threshold in the beam selected by the beam cursor. (Same as PB/)

Miscellaneous

- WBA Soundpath difference between the echoes in Gate A and Gate B in the beam selected by the beam cursor. (Same as SBA)

Assigning Measured Readings to the Displayed Reading Boxes (DISPLAY-RESULTS1 or 2-READING #)

The display includes a total of five boxes where measured values can be displayed (Figure 27 below). Four “small” reading boxes can each contain one of four measured values. A “large” reading box can display, in a larger format, any one of the values shown in the small boxes. To define the reading-box contents:

1. Activate the DISPLAY Menu.
2. Select the RESULTS1 Submenu (or select RESULTS2 for the large reading box).
3. Select the READING box location you wish to specify by pressing , then press  again or turn the Function Knob to choose from several of the selections listed above (available readings depend on designated operating mode).

Note: While TCG reference points are being recorded, two measurement result boxes will be automatically set (if not already configured) to display PSA and P%A values. These result selections will remain locked until the TCG recording process is finished.

When S, D, or P readings are displayed, the TOF Detection Mode (Section 2.8.2) setting for the referenced gate (A or B) is indicated by a ^ (Peak Mode) or a / (Flank Mode).

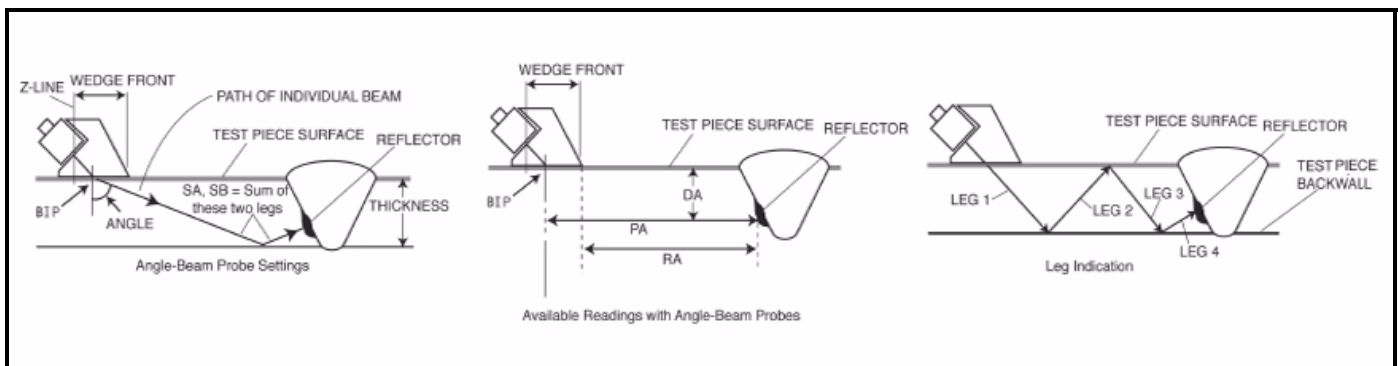





Figure 27: Various measured values available when a probe wedge is used.

3.3 Controlling A-Scan Orientation and Beam Cursor Position

Linking the A-Scan to the Sector or Linear Scan (DISPLAY-VIEW-ASCAN MODE)

When an A-Scan is displayed together with either a Sector or Linear Scan, the A-Scan position can be set to align with the other displayed Scan or the A-Scan can be simply set to display down the full height of the screen (see Figure 28 below). To change the A-SCAN MODE:

1. Activate the VIEW Submenu (located in the DISPLAY Menu) by pressing  below it. Functions will appear down the left side of the display screen.
2. Press  next to the selection titled ASCAN MODE. Continue to press  and note the options are:
 - BUD—Beam Ultrasonic Depth – any vertical location along the A-Scan corresponds to the same vertical location on the beam-cursor selected beam in the Sector or Linear Scan image. This correspondence is maintained, even when the displayed sector's range is modified with changes to the LEG setting (Section 2.6.1).
 - NORMAL—The vertical length of the A-Scan remains constant at full screen height and does not change with changes in the Sector or Linear Scan's display.

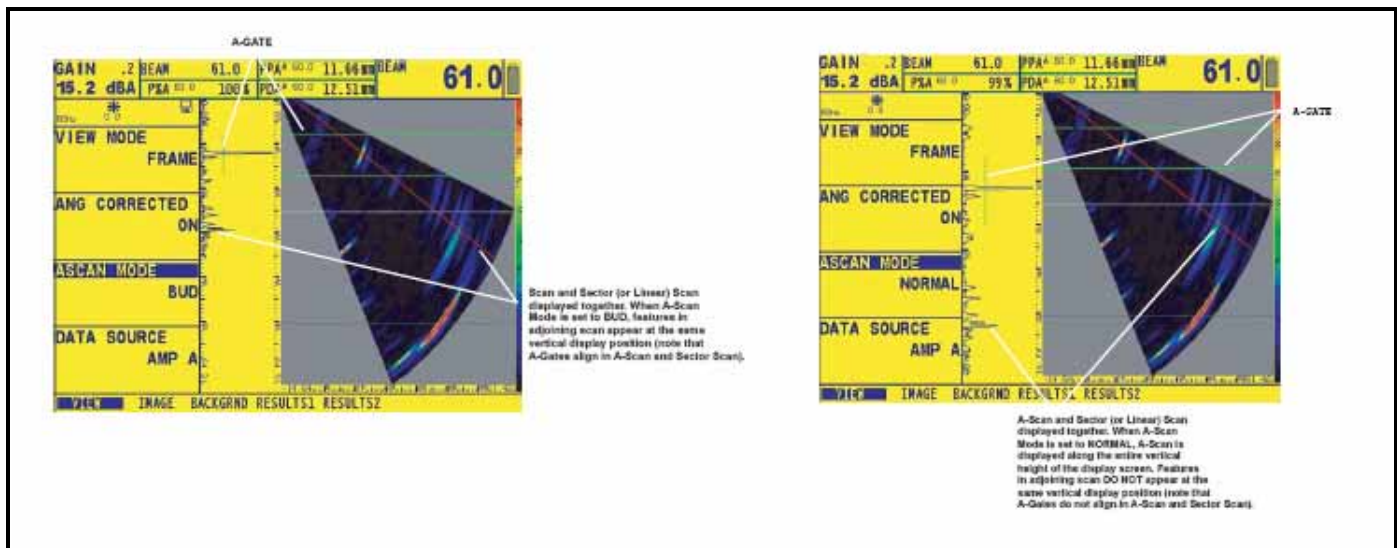



Figure 28: A-Scan Mode setting links the A-Scan's vertical location to the corresponding scans, vertical location, or extends the A-Scan across the full vertical height of the display.



Note: This setting effects the A-Scan only when it is displayed together with either a Sector or Linear Scan.

Controlling the Beam Cursor with the Function Knob (DISPLAY-VIEW-BEAM CURSOR)

Whenever a Sector is displayed, the Beam Cursor appears as a diagonal line across the scan display screen (it appears as a vertical line in Linear Scans). The angular position of this cursor, which can be displayed in a Reading box (Section 3.2), can be controlled by turning the Function Knob. To control the Beam Cursor with the Function Knob:

First press  to reach the Home Menu, then quickly press it again. This will cause all displayed functions to become deselected and will link the Function Knob to the Cursor. Note that moving the beam cursor changes the selected beam and therefore effects the value of those displayed RESULTS that are based on the selected beam (Section 3.2).

3.4 Operating in Freeze Mode (Phased Array)

At any time when operating in Phased Array mode, the display can be frozen by momentarily pressing  (holding  for three seconds will automatically store a dataset or generate a report as called for by the ACTION chosen in the FILENAME Submenu -- see Chapter 6). When frozen, the displayed scans can be manipulated and evaluated using the Freeze Menu shown in Figure 29. Capabilities of the Freeze Menu include:

CURSOR 1—Operate a horizontal cursor with the Gain Knob and a Vertical or Beam Cursor with the Function Knob. It also allows the user to display an ORIGIN LINE corresponding to the WEDGE FRONT plus ORIGIN OFFSET (if any) distances to represent the user-defined target location.

CURSOR 2—Operate a second (color coded) horizontal cursor with the Gain Knob and a Vertical or Beam Cursor with the Function Knob. This menu also allows the user to display an ORIGIN LINE corresponding to the WEDGE FRONT plus ORIGIN OFFSET (if any) distances to represent the user-defined target location.

MEAS 1 and MEAS 2—Select up to four READING options (each) that correspond to the point defined by the intersection of CURSOR 1's and CURSOR 2's horizontal and vertical components.

- SBM1—Soundpath measurement from the selected BEAM at the crossing point with Horizontal Cursor 1
- Z1—uncorrected vertical depth of the horizontal cursor. (See section 3.5.)
- L1-2—Straight line distance from Cursor 1 inter-section to cursor 2 intersection
- P1—Projected horizontal distance from Origin line to Cursor 1 intersection
- AMP1—Amplitude of Image point at Cursor 1 intersection
- P1-2—Absolute Projected horizontal distance from Vertical Cursor 1 to Vertical Cursor 2
- Z1-2—Uncorrected distance from Horizontal Cursor 1 to Horizontal Cursor 2
- Z2—Uncorrected vertical Depth to Horizontal Cursor 2 (See section 3.5.)
- P2—Projected horizontal distance from Origin line to Vertical Cursor 2
- AMP2—Amplitude measurement of image point at Cursor 2 intersection.
- SBM2—Soundpath measurement from the selected Beam at the Horizontal Cursor 2 intersection
- D1 — true-depth for cursor 1. True-depth corrects for the leg number. (See section 3.5.)
- D2 — true-depth for cursor 2. True-depth corrects for the leg number.(See section 3.5.)
- AATT (absolute arrival time technique) — $\text{abs}(D2 - D1)$. The user will use the sector image to determine the placement of the cursors across all beams and simply calculates the size (height) of the flaw as the difference between the top and the bottom of the flaw. (See section 3.5.)
- RATT (relative arrival time technique) — $\text{abs}(Z2 - Z1)/\cos(\text{beam angle})$. This measurement is for subsurface flaws and near-surface flaws. (See section 3.5.)
- OFF

3.4 Operating in Freeze Mode (Phased Array) (cont.)

RESULTS1—Display the four READINGS that were operational prior to freezing the display. Cycle dependent results change with a beam cursor change. Results are only displayed when offline gain is set to 0.0db.

OFFLN DB—Change the Gain that’s applied to the frozen display. The amount of offline gain (in dB) that’s applied to the frozen image is indicated in the icon bar, just below the freeze icon. The offline gain is removed when the display is unfrozen.

FILENAME—Launch the data set naming (or report generating) process as described in Section 6.1.1.

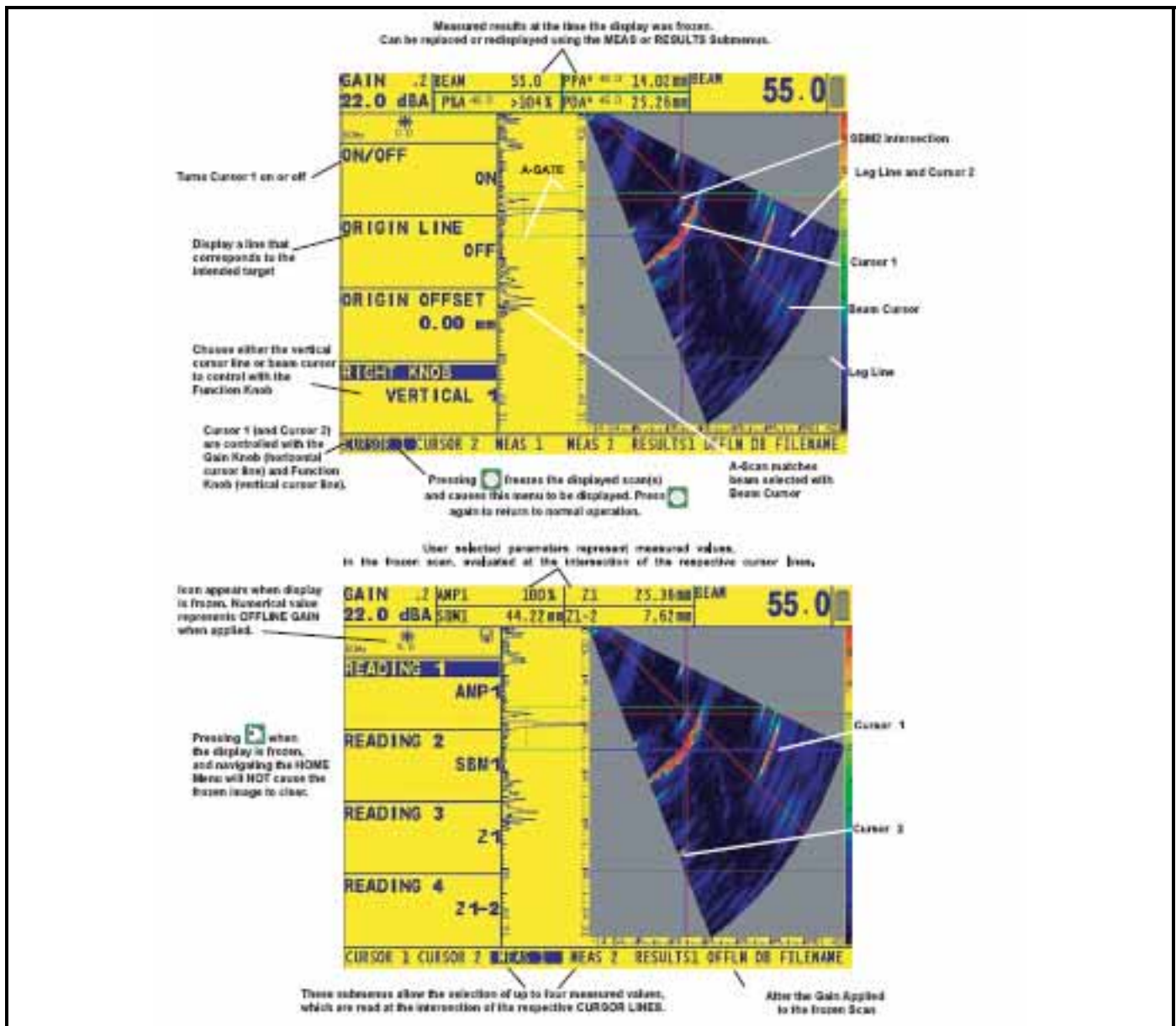

Figure 29: These A and Sector Scans are being evaluated in Freeze Mode.

3.4 Operating in Freeze Mode (Phased Array) (cont.)

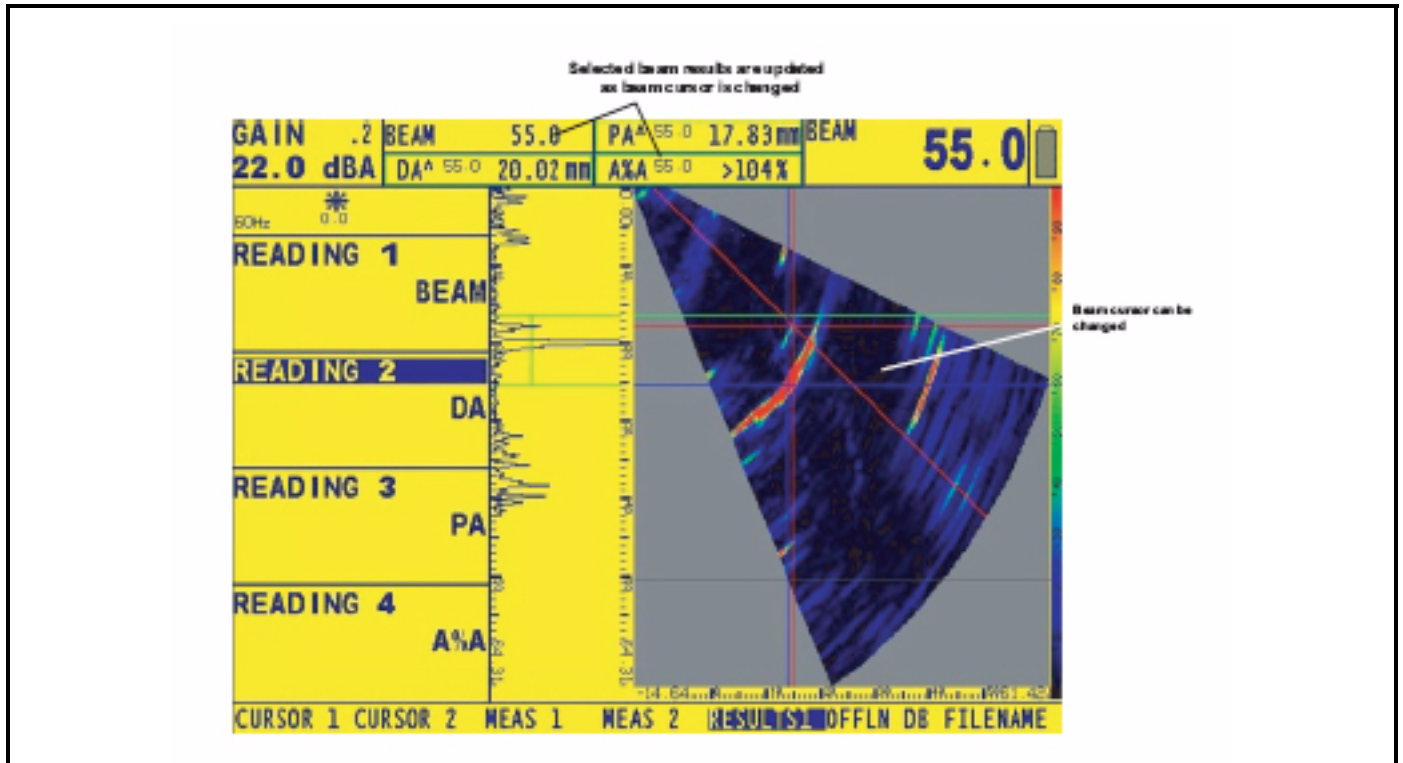

Figure 30: Results are updated according to the selection of the beam cursor.

3.5 Tip Diffraction Sizing Technique in A-Scan

The tip diffraction sizing technique must be performed in Frame View Analysis (Freeze mode). When the frame image is an angle-corrected sector scan with A-scan mode set to BUD, the CURSOR 1 and CURSOR 2 bars will “extend” into the A-scan window.

The tip diffraction calculations are:

- $D1$ = true-depth for cursor 1. True-depth corrects for the leg number.
- $D2$ = true-depth for cursor 2. True-depth corrects for the leg number.
- AATT (absolute arrival time technique) = $\text{abs}(D2 - D1)$
- RATT (relative arrival time technique) = $\text{abs}(Z2 - Z1) / \cos(\text{beam angle})$



With AATT, the user will use the sector image to determine the placement of the cursors across all beams, and AATT calculates the size (height) of the flaw as the difference between the top and the bottom of the flaw.

The RATT measurement is for subsurface flaws and near-surface flaws. If users need the far-surface flaws, they must divide the RATT measurement by 2.

3.6 Setting the Gain (Phased Array)

Analog and digital gain, which increase and decrease the amplitude of A-Scan signals, are adjusted with the Gain Knob (left-hand side of instrument). The instrument's gain can be adjusted while in any menu location except when the dB STEP function is set to LOCK or during alphanumeric editing. Refer to Figure 31.

Digital Gain can be added to as much as 40 dB of Analog Gain. Access to this gain is by a press and hold action on the gain step key. Digital gain allows the user to evaluate signals at higher or lower amplitude in freeze mode. Digital gain is automatically applied depending on aperture selection. Smaller apertures have larger digital gains applied than larger apertures. Available digital gain control is influenced by aperture.

As shown in Figure 31, pressing and holding  next to the ANALOG or DIGITAL GAIN Function bar activates the dB REF feature. This displays a reference gain equal to the sum of the analog and digital gain at the time of activation. It also sets both the dBA and dBD values to zero. All changes to analog and digital gain are then made with respect to these zero initial values. Pressing and holding  again deactivates the dB REF feature but all changes made to the gain settings remain.

Note: Pressing and holding  will switch the type of gain controlled by the Gain Knob between dBD (digital gain) and dBA (analog gain). The type of gain that is NOT controlled by the Gain Knob will appear in the top function bar position and can be controlled by the Function Knob.

Changing the Gain-Adjustment Increment (dB STEP)

When adjusting the A-Scan gain, each click of the gain knob increases or decreases the gain level by a dB increment equal to the dB STEP (identified in Figure 26 on page 54). Several values can be specified for dB STEP, including a Gain Knob LOCK, which prevents any gain adjustment. To select one of the existing dB STEP values:

1. Press .

Note that the dB STEP (gain-adjustment increment) value changes as you continue to push . Available increments include: 0.1dB, 0.2 dB, 0.5 dB, 1.0 dB, 2.0 dB, 6 dB, and LOCK.

2. Once a dB STEP value has been selected, each click of the Gain Knob will increase or decrease the instrument's gain by the dB STEP increment.

Note: Pressing and holding  will switch the type of gain controlled by the Gain Knob between dBD (digital gain) and dBA (analog gain). The type of gain that is NOT controlled by the Gain Knob will appear in the top function bar position and can be controlled by the Function Knob.

Locking the Gain Rotary Knob

The gain knob can be locked so that turning it has no effect on the instrument.

1. Continue pressing  while observing that the value of dB STEP (in the upper left-hand corner of the display) changes to various step values. When the word LOCK appears as the dB STEP value, the gain knob is locked.
2. To unlock the knob, change the setting of dB STEP to some value other than LOCK.

Note: Both knobs are disabled whenever operating in Knob Emulator mode .

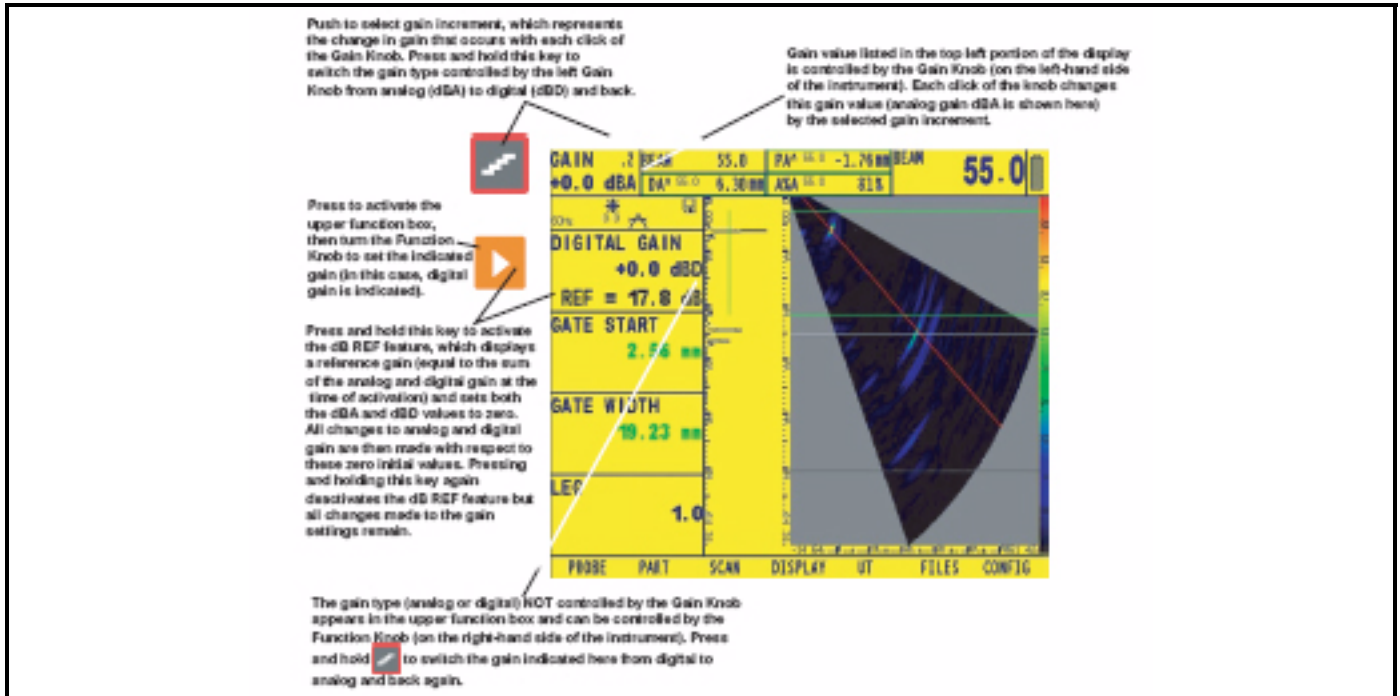



Figure 31: Setting Analog (dBA) and digital (dBD) Gain and using the dB REF Feature.

3.7 Operating in TCG Mode (Phased Array)

The depth at which identical reflectors occur causes variation in the amplitude of resulting ultrasonic echoes. In phased-array sector-scan mode, the TCG feature compensates for the natural signal decay that results from attenuation, the influence of “distance laws,” and also the effect of beam angle on echo amplitude (Figure 32 on page 69).



To account for the effect of beam angle on echo amplitude, TCG reference recording requires that each reference reflector be detected by every beam angle (described in Section 3.7.3). Alternatively, TCG points can be manually entered as described in Section 3.7.4. To ensure that the reference reflector is detected by each beam angle, the Amplitude-Cycle-Diagram is displayed along with the sector scan throughout the standard recording process. Created as the probe is moved over the reference reflector (Figure 33 on page 70), this curve represents the reflected amplitude obtained for each beam angle. The instrument requires that a valid amplitude be measured for each beam angle before the TCG reference point can be recorded (Section 3.6.1).

When operating in TCG mode,  will appear on the display screen. Before using the TCG Function, do the following:

- Ensure that all instrument settings (PULSER, RECEIVER, etc.) have been made. Changing these settings after the TCG reference points are input will affect the accuracy of measurement.
- Carefully calibrate the instrument for the probe/material combination prior to beginning the TCG recording process.
- Set the MAT THICKNESS and LEG values so that all reference reflectors will fall within the displayed sector. These settings can not be adjusted while recording TCG points.
- TCG reference points (up to 15) must be recorded by obtaining an A-Scan echo of a representative reflector or manually entered using the TCG EDIT Submenu. The reference points allow the instrument to calculate and compensate for the effect of material attenuation on reflector-amplitude height. The dynamic range of the TCG function is 40 dB. Maximum curve slope is 6 dB per microsecond. Successive data points do not have to decrease in amplitude. That is, the TCG curve does not have to have a constantly descending slope.

3.7.1 Recording the TCG Reference Points

TCG reference points are typically taken from a standard with equally sized reflectors (holes) located at various material depths. The primary echo from each of these points (for up to a total of 15 echoes) are recorded. When TCG is active, the instrument compensates for different material thickness and different detecting-beam angles by applying a varying gain level to echoes at material depths other than the baseline depth. Only one set of TCG reference points can be stored at a time. To record TCG reference points:

1. A-Gate is used to record the reference echoes. Set GATE START and WIDTH to evaluate only the selected reference echo. Set THRESHOLD to 5% in order to include any signal height above 5% FSH.
2. Access the NRM/TCG Submenu (located in the UT Menu) by pressing .
3. Start the recording process by pressing  (two times) next to RECORD so that POINT 1 appears. Couple the phased array probe to the test standard so that at least one “step” segment on the display’s left side (see Figure 34 on page 72) indicates the reflector’s presence. As seen in Figure 34, display segments move to the right from their baseline position by an amount that’s proportionate to their maximum amplitude. Note that changing Gain setting or moving the A-Gate THRESHOLD will alter the amplitude at which this reflector is detected in A Gate.

3.7.1 Recording the TCG Reference Points (cont.)

Note: During the recording process, the gain applied to one or more beam group segments can be reduced to eliminate the effect of an undesired reflector (such as a geometric feature that is detected by these specific segments) on the recording of a TCG point. See Section 3.7.2 to select a region of interest during the TCG-point recording process.

Note: The cyclic gain feature (Section 3.7.3) adds an incremental amount of gain to each beam group.

4. Move the probe so that additional segments on the display's left side indicate the presence of the first reflector. Again, display segments move to the right from their baseline position by an amount that's proportionate to the maximum A-Scan amplitude (in A Gate) they acquire. All segments must indicate the presence of the reflector (by moving to the right of their baseline position) and no segment may indicate an amplitude greater than 100% full-screen-height. Ideally, with sufficient movement of the probe, display segments will represent somewhat consistent amplitudes.

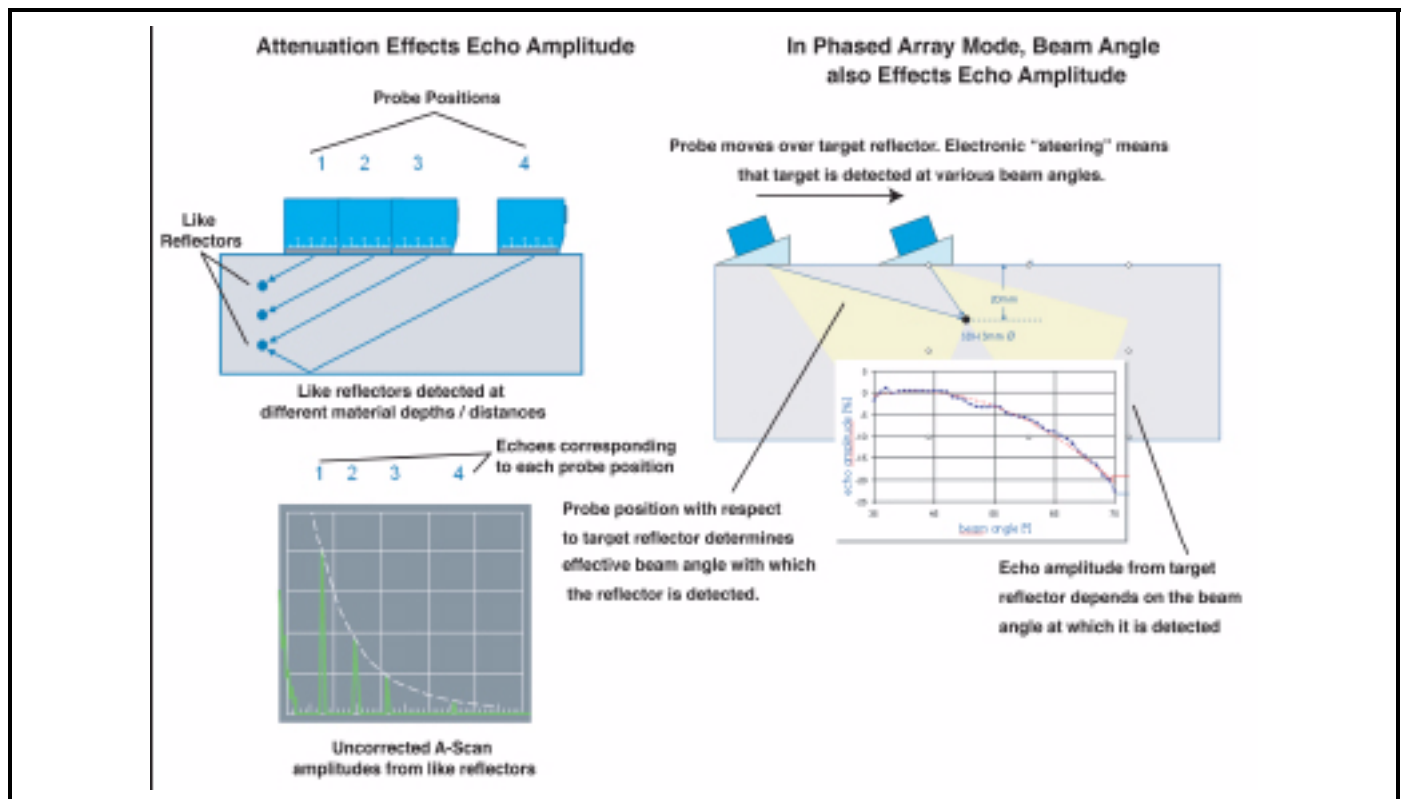

Figure 32: Why compensation may be needed.

3.7.1 Recording the TCG Reference Points (cont.)

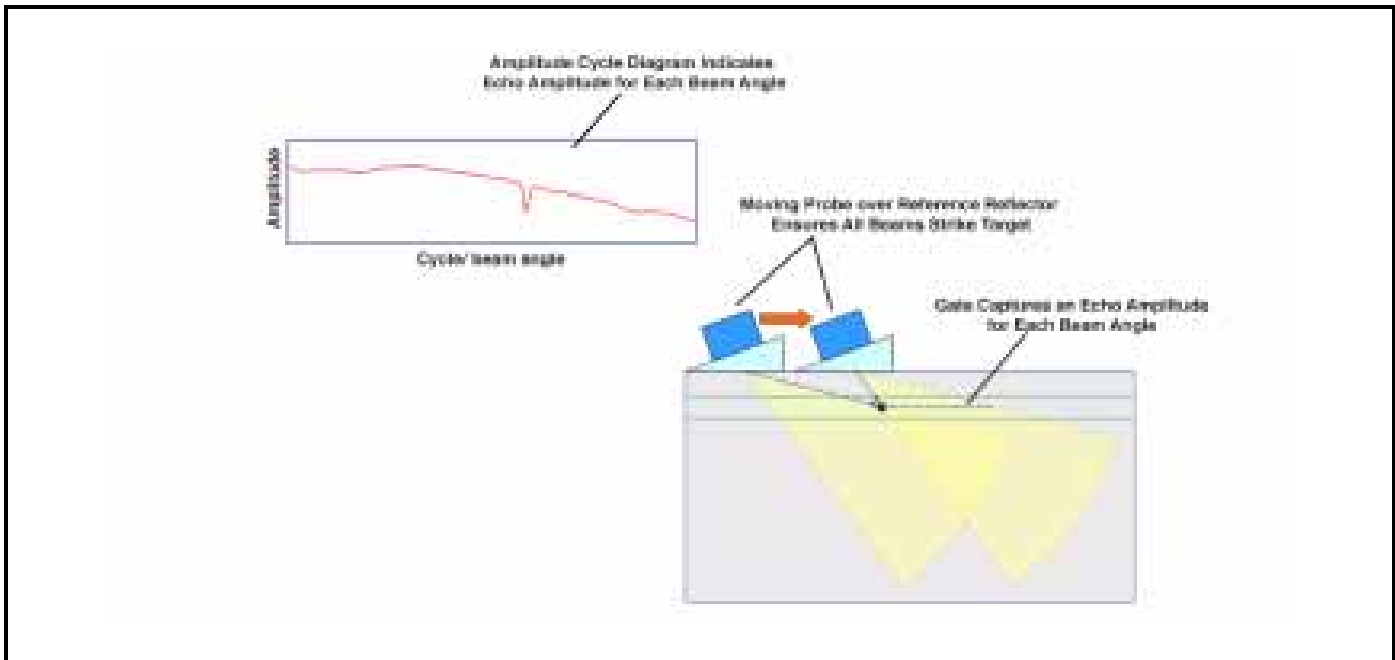





Figure 33: The Amplitude Cycle Diagram indicates the TCG-reference amplitude recorded at each beam angle.

5. After each display segment sufficiently indicates the reflector's presence, press  to record POINT 1.

Note: Pressing and holding  (for three seconds) that appears next to the <RECORDING> Function deletes the currently active TCG point.



6. Continue to move the probe to observe additional reference points and repeat Steps 2 and 3 until TCG points for all reflectors are recorded (up to a maximum of 15). Then press  (two times) next to FINISH. At this time the TCG Curve is generated and active. The effects of TCG can be turned on or off (TCG MODE) without deleting the reference points. However, the curve must be deleted before a new TCG can be recorded.
7. Access the TCG EDIT Submenu to add points to or otherwise adjust the existing TCG Curve after it has been finished. To delete curve, press  and hold key.

Note: When a TCG reference point is stored, two measurement result boxes will be automatically set (if not already configured) to display PPA and P%A values. These result selections will remain locked until TCG reference recording is completed (Step 6 above).

Note: TCG reference points and status (OFF or TCG) will be stored with data set. When recalled, curve status will be the same as when it was stored. For example, if TCG is active when a data set is stored, it will be active when that data set is recalled.

3.7.2 Selecting Beam-Groups of Interest During the TCG Recording Process

During the recording process, the gain applied to one or more beam-group segment can be reduced to eliminate the effect of an undesired reflector (such as a geometric feature that is detected by these specific segments) on the recording of a TCG point. To select a region of interest during the TCG-point recording process:

1. Press  next to the BEAM GROUP Function (identified in Figure 33 on page 70).
2. Identify the first beam group(s) for which you want to define a TCG point.
3. Adjust gain as required and record the TCG reference data (by pressing  next to RECORDING) for the indicated group(s). The instrument will NOT proceed to the next TCG point at this time.
4. As prompted, continue to identify beam groups and apply suitable gain to those groups, recording the beam groups as described in Step 4.
5. When data has been recorded for all beam groups, the TCG recording process will automatically proceed to the next TCG point.

3.7.3 Applying Incremental Gain to Beam Groups During the Recording Process

The cycle gain control feature allows an incremental amount of gain (measured in dB) to be added to each beam. Prior to beginning the TCG-point recording process, press  next to the CYC GAIN CNTL Function then turn the Function Knob to incrementally apply the indicated amount of gain to each beam.

For example: applying an additional 2 dB to three beams in this manner means that 2 dB is added to the first beam, 4 dB added to the second, and 6 dB added to the third.

After the TCG-point recording process has begun, cycle gain can still be added by pressing the same key, identified in Figure 34 on page 72. (**WARNING:** pressing this key twice will finish the TCG process.)

3.7.3 Applying Incremental Gain to Beam Groups During the Recording Process (cont.)

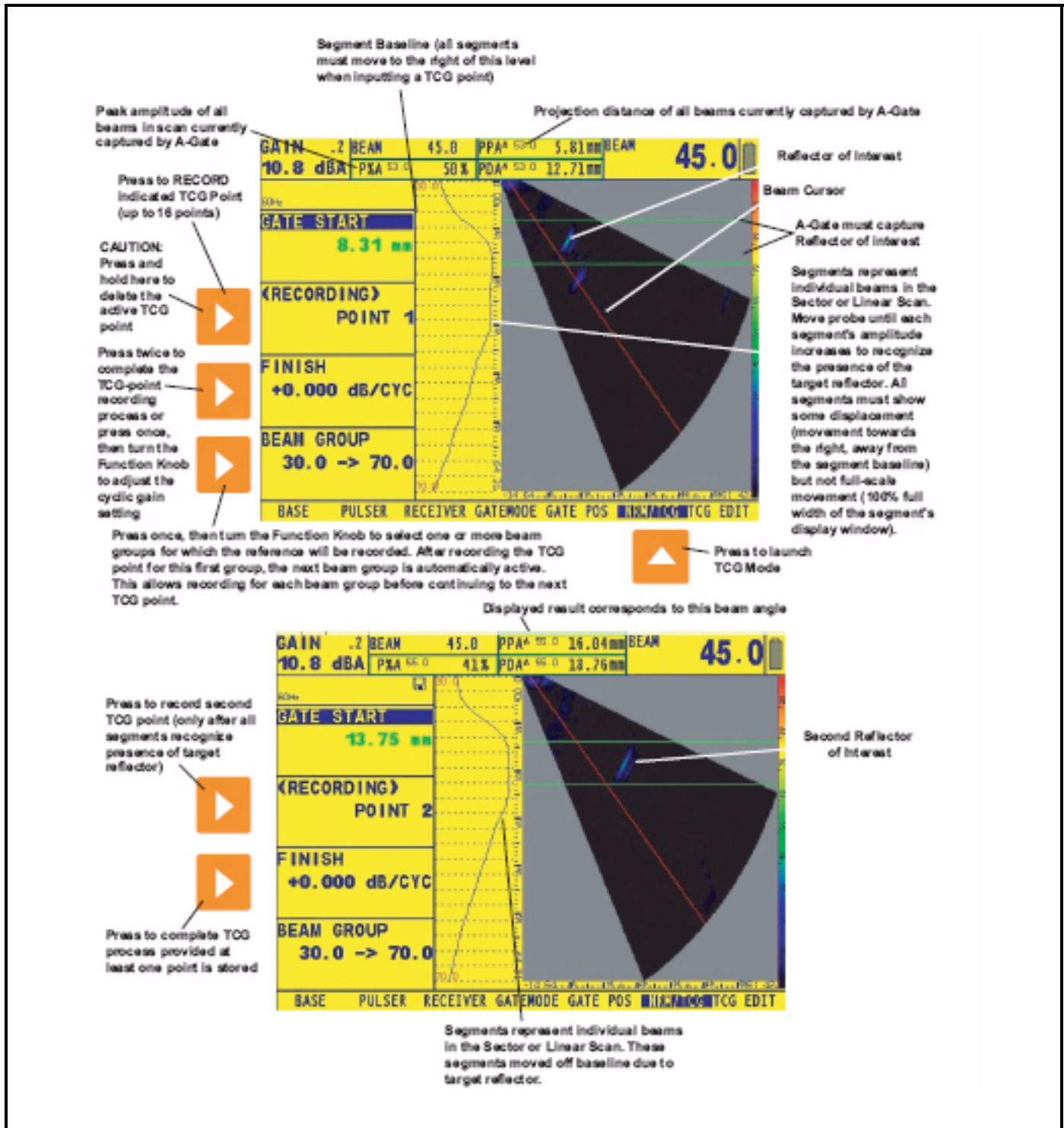







Figure 34: TCG Recording Process

3.7.4 Manually Inputting TCG Points

TCG reference points may also be manually input using the TCG EDIT Submenu, as shown in Figure 35 on page 75. When manually inputting TCG points, the material-depth measurement (called POINT POS.) and additional gain to be applied at that A-Scan depth, is entered for up to 15 points.



Note: TCG points can be manually stored one beam at a time, or for all beams in the scan at once. To edit all beams at once, set the BEAM CURSOR Function at either of its extreme positions. This condition, shown in Figure 35 on page 75, causes all available beams (such as 1 through 57, if the scan includes a total of 57 beams) to be listed. Alternatively, set the BEAM CURSOR Function to each beam (Step 4 below), continue with the process of recording the TCG point settings for that beam, then continue to the next beam until all beams in the scan are complete. This results in a single TCG point being stored (Step 6 below) and allows the process to continue if additional points are required. To manually define a TCG curve:

1. Access the NRM/TCG Submenu (located in the UT Menu) by pressing .
2. Start the recording process by pressing  (two times) next to RECORD so that POINT 1 appears.
3. Access the TCG EDIT Submenu.
4. Press  to activate the BEAM CURSOR Function and set its value to a single beam, or turn in to one of its extremes to select all beams in the SCAN (see Figure 34 on page 72).
5. Press  to activate the POINT Function and set its value to NEW.
6. Press  next to POINT POS. and POINT GAIN, then turn the Function Knob. Set these values to correspond with the desired position and applied gain level of the first TCG point.
7. When the first TCG point's position and gain are correctly set, press  next to POINT (two times) to record the defined point.
8. Turn the Function Knob to set the POINT Function to NEW again and continue the process described in Steps 4 through 8 until up to 15 desired TCG points are entered.

3.7.5 Editing TCG Points

After creating a TCG Curve, modifications can be made to the amplitude or time-based position of existing points. In addition, more points (up to a total of 15) can be added to the existing TCG using the TCG EDIT Submenu.

To modify an existing TCG:

1. Press  below TCG EDIT Submenu (located in the UT Menu).
2. Four functions are available to allow for curve modification:
 - **BEAM CURSOR**—Select the beam (angular position in sector-scan mode or shot number in linear-scan mode) to be edited. Note that edits can be made beam-by-beam or to all beams at once. To edit all beams at once, set the BEAM CURSOR Function at either of its extreme positions. This condition, shown in Figure 34 on page 72, will cause all available beams (such as 1 through 57, if the scan includes a total of 57 beams) to be listed.
 - **POINT**—Select the existing point to modify (alter the applied gain or time-based position) or set to NEW to enter an additional point. Points can also be entered to create a new curve (when no curve is present). Note that the total number of points (either acquired or inputted) can not exceed 15.
 - **POINT POS.**—Modify (or input for NEW points) the time position of a TCG point. As exiting points are selected with the POINT Function, their present time-based position will be displayed. Simply press  next to the POINT POS. Function and turn the Function Knob to alter this value. When a NEW point is selected, the POINT POS. Function will be initially set to 0, but can be modified in the same way. Note that an existing point can be deleted (removed from the curve) by changing the value of its POINT POS. to 0.
 - **POINT GAIN**—Modify (or input for NEW points) the time position of a TCG point. As exiting points are selected with the POINT Function, their present gain level will be displayed. Simply press  next to the POINT GAIN Function and turn the Function Knob to alter this value. When a NEW point is selected, the POINT GAIN Function will be initially set to 0, but can be modified in the same way.

Note: Edited or newly input time or gain values will take effect only after the BEAM or POINT value is changed.

Note: Once recorded, TCG points can be edited or the entire curve they make up can be deleted. A stored curve must be deleted before another curve can be created. To delete the stored TCG curve, press (two times) that appears next to the DELETE CURVE Function in the NRM/TCG Submenu.

Note: When depth calibration mode is on, editing of the 1st and 2nd recorded references are blocked.

3.7.5 Editing TCG Points (cont.)

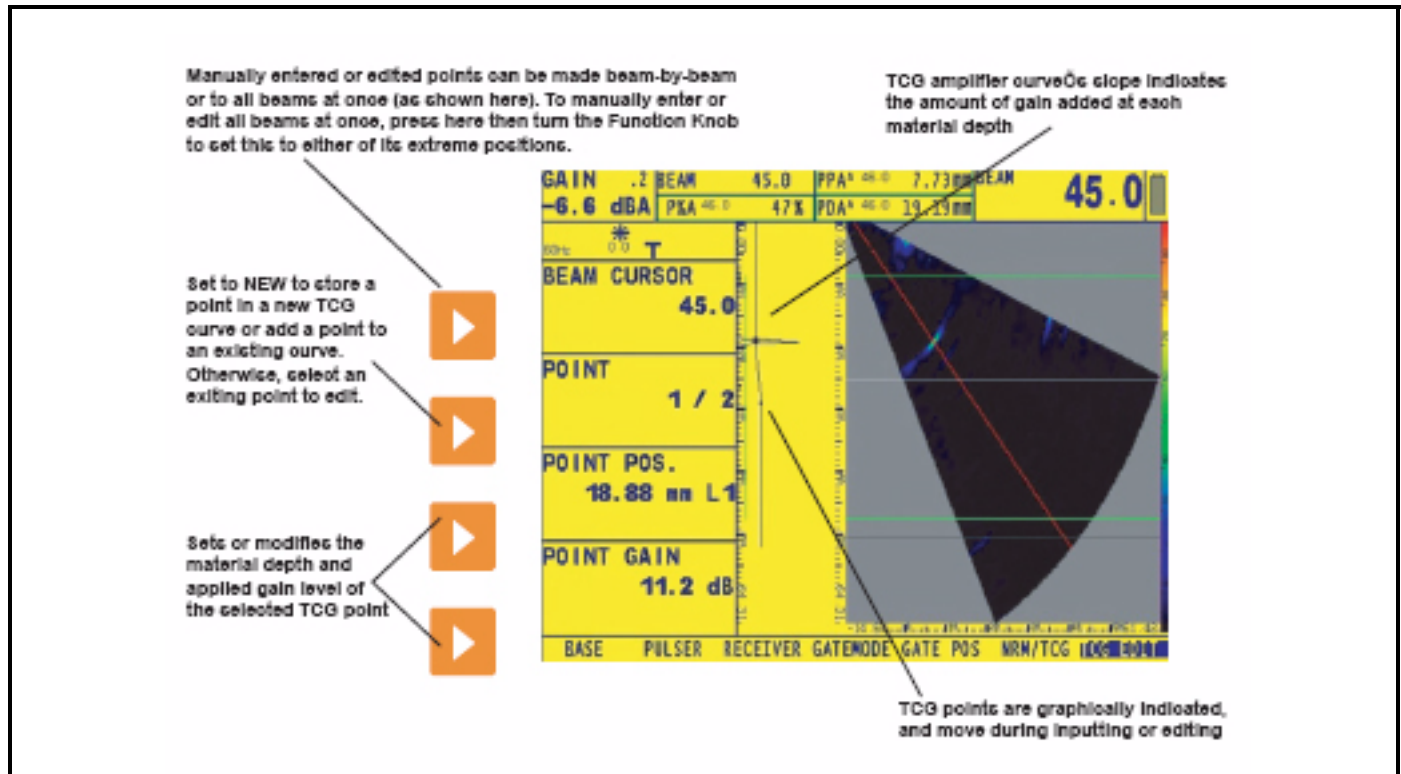

Figure 35: TCG points can be manually inserted to create a new TCG curve or to add new points to an existing curve. Note that TCG data can be stored or edited for one beam at a time or for ALL beams in a scan by adjusting the BEAM CURSOR Function.

Chapter 4. Conventional Operation: Menu System, Keypad, and Displays

When operating in conventional ultrasonic mode, the instrument provides ultrasonic flaw detection and thickness measurement. In this mode, it is capable of storing A-Scans, operating parameters, and reports. This chapter of your manual will help you become more familiar with the menus and functions of the conventional (non-phased array) system.

After reviewing this chapter, you'll be able to

- Supply power to the instrument (Section 4.1)
- Power up the instrument (Section 4.2)
- Understand the function of each key on the keypad (Section 4.3)
- Access each conventional mode function using the built-in menu system (Section 4.4)
- Interpret the symbols that most often appear on the display (Section 4.5)
- Set up the instrument's display and basic operating features (Section 4.6)
- Install a conventional probe and configure the Pulsar/Receiver to match the probe type (Section 4.7)
- Adjust the A-Scan display screen's appearance (Section 4.8.)
- Calibrate the instrument (Section 4.9)
- Set the reminder alarm (Section 4.10)
- Input option activation code (Section 4.11)

4.1 Supplying Power

The instrument operates on a Lithium battery pack located in the rear of its housing, or by using the power adapter (Figure 36 below). To remove the battery compartment cover, first remove the four thumb-screws. The standard Lithium battery pack will provide maximum operating life between charging.

Note: Only the dedicated GEIT Lithium battery pack should be used. Only this pack can be charged while installed in the instrument.

Note: To ensure that the battery pack is fully recharged, the battery charger must be attached to the battery pack before it is plugged into an AC power source.

The approximate level of remaining battery life is visually displayed by the  icon. The location of this icon is shown in Figure 37 on the next page. When a fully charged battery pack is installed, the icon will appear as “full.” As the battery life is consumed, the icon will begin to “empty.”

Note: When the battery indicator is in the last quarter as indicated by the symbol , charge the battery pack as soon as possible. The instrument automatically shuts off when batteries are too weak for reliable operation. Settings are saved and restored when the instrument is turned on again. When testing in remote locations, always carry a spare battery pack.

Note: By connecting the optional Power Adapter, the instrument can be operated using an AC power source. This adapter is connected to the instrument through the Power Adapter Port shown in Figure 36.

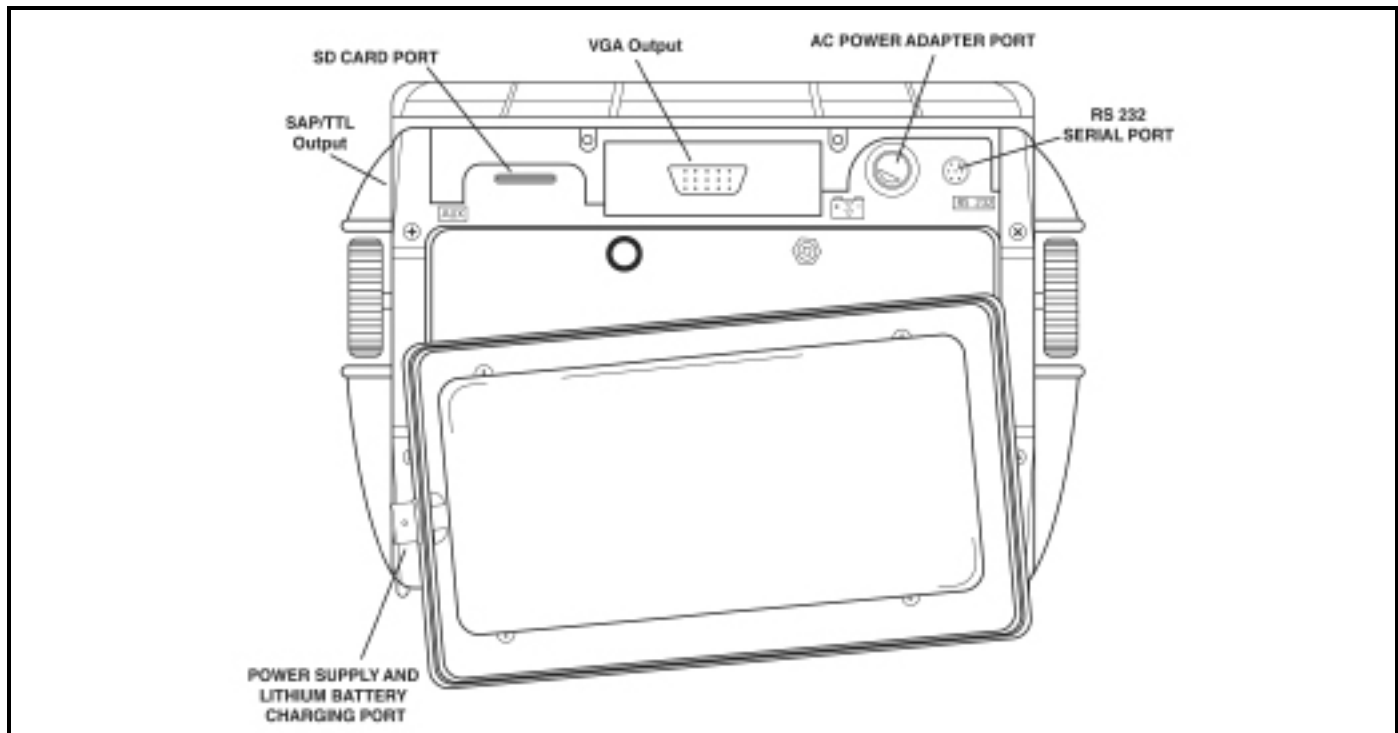



Figure 36: Installation of standard Lithium battery pack. Note the location of the Power Adapter Port and Lithium battery pack on-board charging port.

4.2 Powering On and Off the Instrument



Press  to power the instrument on and off. To select an operating mode, choose from:

- **Phased Array Mode**—Adjust all parameters related to phased-array measurement (see Chapter 1)
- **Conventional Mode**—Adjust all parameters related to conventional ultrasonic measurement

See Section 1.6 to set the mode in which the instrument starts up.

4.3 Keypad and Knob Features

The instrument is designed to give the user quick access to all of the instrument's functions. Its easy-to-use menu system allows any function to be accessed with no more than three key presses (Figure 37 on page 80). To access any function:

- Press one of the seven menu keys  to select a menu. The menus across the bottom of the display will immediately be replaced with the submenus contained in the selected menu.
- Press a menu key  again to select the submenu containing the desired function.
- Up to four functions will be displayed in the function bar on the left side of the display. Select the desired function, by pressing one of the four function keys .
- Change the value listed in the function box with the function knob. Some values can also be adjusted with repeated presses of the function key.

You'll also find these keys and knobs on the instrument:



—*Mode Selector Key* press to choose from Phased Array or Conventional Ultrasonic Operating Modes



—*Home Key* immediately returns the instrument to the Home Menu list as shown in Figure 38 on page 81.



—*Gain Step Key* selects the amount of gain level change that occurs with each click of the Gain Knob.



—*Zoom Key* expands the displayed image to fill the entire screen. Press again to return to normal view mode.



—*Freeze Key* freezes the A-Scan display. Press and hold for 3 seconds to generate a report (Section 3.4).



—*Power Key* turns the instrument on and off.

Function Rotary Knob – Rotate to change the value of the selected function.

Gain Rotary Knob – Rotate to change the instrument's gain.



—*Knob Emulator Key* switches from the Home Menu to the Knob Menu, which allows you to perform Knob functions using the keypad.



—*Gate Magnify Key* magnifies the displayed image, expanding to full-screen-width the gate selected in the EVAL MODE Submenu.

4.3 Keypad and Knob Features (cont.)

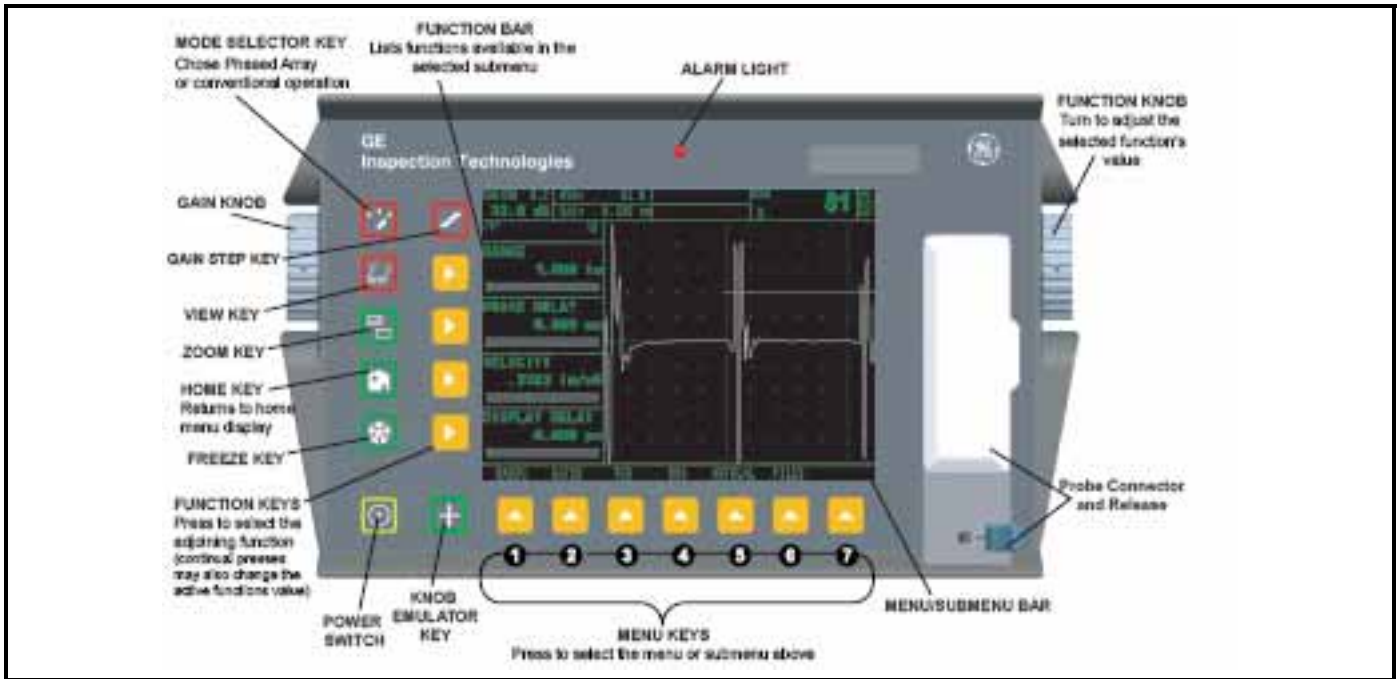

Figure 37: Some of the keypad and knob functions are shown here.

SETUP MENU	GATES MENU	EVAL MENU	{EVAL} ¹ MENU	FILES MENU	CONFIG MENU
RANGE Range Probe Delay Velocity Display Delay	GATE A Gate A Start Gate A Width A Threshold TOF Mode	TRIG Probe Angle Thickness X Value O-Diameter		FILENAME Filename Source/Dest Action Enter	DISPLAY Color Grid Ascan Color Brightness
PULSER Voltage Energy Damping PRF Mode	GATE B Gate B Start Gate B Width B Threshold TOF Mode	EVALMODE Eval Mode Color Leg Magnify Gate		HEADER Header Number Edit Hdr in Report	REGIONAL Language Units Dicemal Date Format
RECEIVER Frequency Rectify Dual Reject	GATEMODE Gate A Logic Gate B Logic Output Select	RESULTS Reading 1 Reading 2 Reading 3 Reading 4		MEMO Edit Memo in Report	STARTUP Startup Date Format Time
GAIN User Gain Step		RESULTS2 Mode Reading 5 Reading 6		REPORT Image in Report Param in Report	CALALARM Reminder Reset
AUTOCAL Gate A Start S-Ref1 S-Ref2 Record		GATE A Gate A Start Gate A Width A Threshold TOF Mode			
GATE A Gate A Start Gate A Width A Threshold TOF Mode		GATE B Gate B Start Gate B Width B Threshold TOF Mode			
GATE B Gate B Start Gate B Width B Threshold TOF Mode					CODE Serial Number Code Confirm

¹{EVAL} Menu is dynamic, based on the value of EVAL→EVALMODE→EVAL MODE

Figure 38: These conventional menus, submenus, and functions are accessed through the Home Menu.





4.4 Home Menu, Eval Menus, and Functions

The menu system allows the operator to select and adjust various features and instrument settings. It includes:

Conventional Operation Home Menu—Several menus used to configure and calibrate the instrument prior to test. Also used to select pulser and receiver characteristics, position gates, set alarms, specify operating mode and screen appearance, adjust the A-Scan display, and control other significant measurement features

Note: Figure 38 on page 81 shows the instrument's Home Menu structure. The information provided in the following two manual sections explains what each function does and shows how to access the function through the menu system. The EVALUATION MODE Function (located in the EVAL Menu) determines which results-evaluating submenu appears in the HOME Menu (these options are listed in Figure 41 on page 93). You'll also find operation-manual section references that tell you where to turn in this manual for more specific information on each function.

The Home Menu System consists of several menus, submenus, and functions.

- If not displayed, conventional mode is accessed by pressing .
- Available menus are accessed via the Home Menu (Figure 38 on page 81).
- Each menu contains several submenus.
- Menus used for evaluating results (TCG, DAC, DGS, dB REF, AWS, and JISDAC) are first selected by the user (via the EVAL MODE function). The evaluation menu selected then appears in the HOME Menu.
- Menus and submenus are selected by pressing  below the desired item.
- When a submenu is selected, the functions contained in that submenu are listed in the Function Bar down the left-hand side of the display screen.
- Functions are then selected by pressing the adjacent Function Key .
- Turning the Function Knob, and in some cases continuing to press , will change the value shown in the selected function's box. In some cases, pressing and holding  will set the function's value to zero.

Note that some functions, like RANGE, have both coarse and fine adjustment modes. Coarse and fine modes are selected by pressing  more than once. When the function name, such as RANGE, appears in all capital letters, turning the function knob will produce large changes in the selected function's value. When the function name appears in all lower-case letters, turning the function knob will change the value by smaller amounts. Functions with coarse-and-fine adjustment capabilities are noted with an * in Figure 40 on page 92.

Note: Figure 39 on page 87 displays the structure of all menus available for evaluating conventional data. Use the EVAL MODE function, in the EVAL Menu, to choose the feature used for evaluating results (TCG, DAC, DGS, dB REF, AWS, or JISDAC). Once selected, the menu corresponding to the EVAL MODE setting is directly accessed through the HOME Menu.

4.4 Home Menu, Eval Menus, and Functions (cont.)

SETUP Menu

RANGE Submenu

- **RANGE**—Adjusts the range of the display screen from .040” to 300” in steel. (Refer to Section 4.8.1.)
- **PROBE DELAY**—Represents the time delay caused by sound-wave travel through a probe’s wearplate, membrane, delay line, or wedge. (Refer to Section 4.9.2.)
- **VELOCITY**—Displays the velocity for the selected material and allows the user to input a velocity. (Refer to Section 4.9.2.)
- **DISPLAY DELAY**—Shifts the A-Scan viewing window to the left or right. (Refer to Section 4.8.)

PULSER Submenu

- **VOLTAGE**—Sets pulser voltage level (Refer to Section 4.7.4)
- **ENERGY**—Sets energy level of pulse (Refer to Section 4.7.5.)
- **DAMPING**—Adjusts the damping level to match the installed probe. (Refer to Section 4.7.)
- **PRF MODE**—Selects the mode by which the Pulse Repetition Frequency is determined. Displays and/or allows adjustment of its value. (Refer to Section 4.7.3.)

RECEIVER Submenu

- **FREQUENCY**—Selects the bandwidth of the instrument. (Refer to Section 4.7.2.)
- **RECTIFY**—Selects the rectification-mode which effects how the A-Scan appears on the display. (Refer to Section 4.7.4.)
- **DUAL**—Identifies whether a single-element probe or a dual element probe is installed (Refer to Section 4.7.2.)
- **REJECT**—Determines what percentage of the A-Scan height is displayed at 0% full screen height. (Refer to Section 4.7.6.)

Gain Submenu

- **USER GAIN STEP**—Specify a gain value to appear in the dB Step selections. (Refer to Section 5.6.2)

AUTOCAL Submenu (Refer to Section 4.9.)

- **GATE A START**—Shifts the starting point of the A-Gate to the left and right.
- **S-REF 1**—User-input thickness value of the thinner calibration standard.
- **S-REF 2**—User-input thickness value of the thicker calibration standard.
- **RECORD**—Identifies and progresses through each stage of the calibration procedure.

GATE A Submenu (Refer to Section 5.1)

- **GATE A START**—Sets the beginning position of A gate on the A-Scan.
- **GATE A WIDTH**—Sets the width of A gate on the A-Scan.
- **A THRESHOLD**—Sets the height of A gate.
- **TOF MODE**—Indicates whether an A-Scan echo's flank, or peak is evaluated by the A gate. (Refer to Section 5.1.2)

GATE B Submenu (Refer to Section 5.1)

- **GATE B START**—Sets the beginning position of B gate on the A-Scan.
- **GATE B WIDTH**—Sets the width of B gate on the A-Scan.
- **B THRESHOLD**—Sets the height of B gate.
- **TOF MODE**—Indicates whether an A-Scan echo's flank, or peak is evaluated by the B gate. (Refer to Section 5.1.2)

GATES Menu

GATE A Submenu (Refer to Section 5.1)

- **GATE A START**—Sets the beginning position of A gate on the A-Scan.
- **GATE A WIDTH**—Sets the width of A gate on the A-Scan.
- **A THRESHOLD**—Sets the height of A gate.
- **TOF MODE**—Indicates whether an A-Scan echo's flank, or peak is evaluated by the A gate. (Refer to Section 5.1.2)

GATE B Submenu (Refer to Section 5.1)

- **GATE B START**—Sets the beginning position of B gate on the A-Scan.
- **GATE B WIDTH**—Sets the width of B gate on the A-Scan.
- **B THRESHOLD**—Sets the height of B gate.
- **TOF MODE**—Indicates whether an A-Scan echo's flank, or peak is evaluated by the B gate. (Refer to Section 5.1.2)

GATEMODE Submenu

- **A GATE LOGIC**—Determines whether the gate alarm is triggered when a signal crosses the gate or does not cross the A gate. (Refer to Section 5.1.3)
- **B GATE LOGIC**—Determines whether the gate alarm is triggered when a signal crosses the gate or does not cross the B gate. (Refer to Section 5.1.3)
- **OUTPUT SELECT**—Set alarm light and output to indicate when one or both gates are triggered (Refer to Section 5.1.3.)

*EVAL Menu**TRIG Submenu (Refer to Section 5.2)*

- **PROBE ANGLE**—Input the angle of a connected angle beam probe.
- **THICKNESS**—Sets the test-piece material thickness for angle-beam measurements.
- **X VALUE**—Input the specified value from the angle beam probe's BIP to front edge.
- **COLOR LEG**—Indicates in which leg a reflector is located. (Used with angle beam probes.)

RESULTS Submenu (Refer to Section 5.3)

- **READING 1 THROUGH READING 4**—Selects the measurement displayed in each of the four Reading Boxes. (Refer to Section 5.3)

RESULTS2 Submenu (Refer to Section 5.3)

- **MODE**—Set the large reading box to display one or two results
- **READING 5 / LRG**—Select the measurement displayed in the large or fifth (if the large box is split) result box.
- **READING 6**—Select the measurement displayed in the sixth (when the large box is split) result box.

GATE A Submenu (Refer to Section 5.1.1)

- **GATE A START**—Sets the beginning position of A-Gate on the A-Scan.
- **GATE A WIDTH**—Sets the width of A-Gate on the A-Scan.
- **A THRESHOLD**—Sets the height of A gate on the A-Scan.
- **TOF MODE**—Indicates whether an A-Scan echo's flank or peak is evaluated by the A gate.

GATE B Submenu (Refer to Section 5.1.1)

- **GATE B START**—Sets the beginning position of B-Gate on the A-Scan.
- **GATE B WIDTH**—Sets the width of B-Gate on the A-Scan.
- **B THRESHOLD**—Sets the height of B gate on the A-Scan.
- **TOF MODE**—Indicates whether an A-Scan echo's flank or peak is evaluated by the B gate.

FILES Menu

FILENAME Submenu (Refer to Section 6.1 and Section 6.6)

- **FILENAME**—Select stored files or input new data set or report name.
- **SOURCE/DEST**—Indicates the device to or from which data is sent.
- **ACTION**—Recalls or deletes the selected file and saves edits to data sets and reports.
- **ENTER**— Causes specified ACTION to occur.

HEADER Submenu (Refer to Section 6.5)

- **HEADER NUMBER**—Selects the Header Line to edit.
- **EDIT**—Set to YES to allow editing of the selected Header Line.
- **HDR IN REPORT**—Determines if the header will be included in the generated report.

MEMO Submenu (Refer to Section 6.4)

- **EDIT**—Allows editing / creation of the Memo.
- **MEMO IN REPORT**—Determines if the memo will be included in the generated report.

REPORT Submenu (Refer to Section 6.6)

- **IMAGE IN REPORT**—Determines if the displayed Scan(s) will be included in the generated report.
- **PARAM IN REPORT**—Determines if instrument settings will be listed in the generated report.

CONFIG Menu

DISPLAY Submenu (Refer to Section 4.6)

- **COLOR**—Changes the colors of the display
- **GRID**—Selects the display screen's grid markings.
- **A-SCAN COLOR**—Adjusts the color of the A-Scan
- **BRIGHTNESS**—Adjusts the display's brightness

REGIONAL Submenu (Refer to Section 4.6)

- **LANGUAGE**—Sets the language displayed on the instrument's screen
- **UNITS**—Sets displayed units to inch or millimeter
- **DECIMAL**—Selects a comma or period to represent a decimal point
- **DATE FORMAT**—Sets the format of the displayed date

STARTUP Submenu (Refer to Section 4.6)

- **STARTUP MODE**—Indicates if instrument is to start in the last active mode or at the Welcome Screen (Refer to Section 1.6)
- **DATE**—Sets the displayed date (Refer to Section 2.1)
- **TIME**—Sets the displayed time (Refer to Section 2.1)

CALALARM Submenu (Refer to Section 4.10.)

- **REMINDER**—Sets the elapsed time duration between reminder alarm triggering
- **RESET**—Satisfies the triggered alarm

CODE Submenu (Refer to Section 4.11.)

- **SERIAL #**—Instrument’s serial number
- **CODE**—Enter activation code to enable purchased options
- **CONFIRM**—Press twice to confirm activation code

Evaluation Menus Available

When operating in Conventional Mode, the instrument offers various result-evaluating options. Submenus used for evaluating results (TCG, DAC, DGS, dB REF, AWS, and JISDAC) are first selected by the user via the EVAL MODE Function. The evaluation menu selected then appears in the HOME Menu.

Note: Figure 39 below displays the structure of all menus available for evaluating conventional data. This part of the manual explains what each function in these menus does and shows how to access the function. You’ll also find operation-manual section references that tell you where to turn in this manual for more specific information on each function.

EVALUATION MODES AVAILABLE				
DAC/TCG MENU	DGS MENU	dB REF MENU	AWS D1.1 MENU	JISDAC MENU
RECORD + gate A start + autoDB + record + finish	SETUP + dgs mode + dgs curve + probe # + probe name	SETUP + mode + reference + record + delete ref	SETUP + indication + reference + calibration + D1.1 rating	RECORD + gate A start + autoDB + record + finish
GATE A + gate A start + gate A width + A threshold + luf mode	DGS PROB + probe name + luf frequency + ref diameter + delay relay(s)	GATE A + gate A start + gate A width + A threshold + luf mode	GATE A + gate A start + gate A width + A threshold + luf mode	GATE A + gate A start + gate A width + A threshold + luf mode
SETUP + trigger mode + log display + dgs type + dgs curve	REF ECHO + gate a start + reference type + ref value + record ref			SETUP + JISDAC + hold time + delete curve
EDIT + print + print gate + print gate + enter	REF CORR + ref atten + amp correct + delete ref			MAT ATTN + transfer con
MAT ATTN + transfer con	MAT ATTN + test atten + transfer con			
OFFSETS + mode + offset	OFFSETS + offset 1 + offset 2 + offset 3 + offset 4			
OFFSETS + offset 1 + offset 2 + offset 3 + offset 4	GATE A + gate A start + gate A width + A threshold + luf mode			

← Use EVAL MODE function to make one of these menus active

Figure 39: The instrument’s various evaluation menu selections are activated via the EVAL MODE function located in the EVAL Menu. Once selected, the active evaluation mode is added to the HOME Menu.

DAC/TCG Menu

RECORD Submenu (Refer to Section 5.9.1)

- **GATE A START**—Sets the beginning position of A-Gate on the A-Scan.
- **AUTO80**—Press and hold to automatically adjust applied gain to set the value of the highest peak in A gate to 80% of FSH.
- **RECORD**—Record the DAC or TCG reference point captured in A gate.
- **FINISH**—Complete the DAC or TCG reference point recording process (additional points can be added via the EDIT Submenu).

GATE A Submenu (Refer to Section 5.1.1)

- **GATE A START**—Sets the beginning position of A-Gate on the A-Scan.
- **GATE A WIDTH**—Sets the width of A-Gate on the A-Scan.
- **A THRESHOLD**—Sets the height of A gate on the A-Scan.
- **TOF MODE**—Indicates whether an A-Scan echo's flank or peak is evaluated by the A gate.

SETUP Submenu

- **TCG/DAC MODE**—Select between TCG or DAC, or turn feature off (Refer to Section 5.8)
- **TCG DISPLAY**—Turns the TCG curve on or off (Refer to Section 5.10.2)
- **DAC TYPE**—Choose between a traditional curved DAC line and a straight DAC line, which simply connects the recorded DAC points (Refer to Section 5.9)
- **DELETE CURVE**—Delete DAC curve or a set of TCG reference points (Refer to Section 5.13.)

EDIT Submenu (Refer to Section 5.12)

- **POINT**—Identify TCG or DAC point to be modified
- **POINT POS**—Adjust the time-base position of a TCG or DAC point
- **POINT GAIN**—Adjust the gain applied to a TCG or DAC point
- **ENTER**—Input entered changes to the TCG or DAC point

MAT ATTN Submenu (Refer to Section 5.11)

- **TRANSFER CORR**—User input dB compensation for differences between standard and test coupling

OFFSETS Submenu (Refer to Section 5.11)

- **MODE**—Use fixed-displacement positive and negative offset lines (see next submenu) or input individual displacement values for each of up to four offset lines.
- **OFFSET**—value of fixed offset displacement

OFFSETS2 Submenu (Refer to Section 5.11)

- **OFFSET 1**—Displays a line at a fixed-gain offset from the DAC or TCG line
- **OFFSET 2**—Displays a line at a fixed-gain offset from the DAC or TCG line
- **OFFSET 3**—Displays a line at a fixed-gain offset from the DAC or TCG line
- **OFFSET 4**—Displays a line at a fixed-gain offset from the DAC or TCG line

*DGS Menu**SETUP Submenu (Refer to Section 5.13)*

- **DGS MODE**—Displays the stored DGS curve and enables DGS results.
- **GS CURVE**—Positions the stored DGS curve to represent a user-defined flaw size
- **PROBE #**—Designation for built-in probe options (set to 0 for user-defined probe)
- **PROBE NAME**—Name of built-in probe options (set to 0 for user-defined probe)

DGS PROB Submenu (Refer to Section 5.13)

- **PROBE NAME**—Name of built-in probe options (set to 0 for user-defined probe)
- **XTAL FREQUENCY**—Frequency of selected probe
- **EFF DIAMETER**—Diameter of selected probe
- **DELAY VELOCITY**—Delay line velocity of selected probe

REF ECHO Submenu (Refer to Section 5.13)

- **GATE A START**—Sets A-Gate starting point
- **REFERENCE TYPE**—Select DGS reference reflector type
- **REF SIZE**—Set size of DGS reference reflector
- **RECORD REF**—Record reference reflector from which DGS curve is built

REF CORR Submenu (Refer to Section 5.13)

- **REF ATTEN**—Input sound attenuation of DGS reference material
- **MPL CORRECT**—Input specified angle-beam-probe correction value
- **DELETE REF**—Delete stored DGS reference and corresponding curve

MAT ATTN Submenu (Refer to Section 5.13)

- **TEST ATTEN**—Input sound attenuation of test material
- **TRANSFER CORR**—dB compensation for differences between standard and test coupling

OFFSETS Submenu Refer to Section 5.13)

- **OFFSET 1**—Displays a line at a fixed-gain offset from the DGS curve
- **OFFSET 2**—Displays a line at a fixed-gain offset from the DGS curve
- **OFFSET 3**—Displays a line at a fixed-gain offset from the DGS curve
- **OFFSET 4**—Displays a line at a fixed-gain offset from the DGS curve

GATE A Submenu (Refer to Section 5.1)

- **GATE A START**—Sets the beginning position of A gate on the A-Scan.
- **GATE A WIDTH**—Sets the width of A gate on the A-Scan.
- **A THRESHOLD**—Sets the height of A gate.
- **TOF MODE**—Indicates whether an A-Scan echo's flank, or peak is evaluated by the A gate. (Refer to Section 5.1.2)

dB REF MENU

SETUP Submenu (Refer to Section 5.15)

- **MODE**—Turns dB REF feature ON or OFF after a reference is stored
- **REFERENCE**—Indicates the amplitude of and dB gain level of the recorded reference
- **RECORD**—Press to store the echo from which the gain level and all reference amplitude results are based
- **DELETE REF**—Deletes the stored reference.

GATE A Submenu (Refer to Section 5.1.1)

- **GATE A START**—Sets the beginning position of A gate on the A-Scan.
- **GATE A WIDTH**—Sets the width of A gate on the A-Scan.
- **A THRESHOLD**—Sets the height of A gate on the A-Scan.
- **TOF MODE**—Indicates whether an A-Scan echo's flank or peak is evaluated by the A gate.

SETUP Submenu (Refer to Section 5.16)

- **A INDICATION**—dB amplitude of the measured reflector in A gate
- **B REFERENCE**—Stores a reference reflector, then shows its dB amplitude
- **C ATTENUATION**—Calculated dB attenuation to the reflector
- **D D1.1 RATING**—Calculated based on formula for D1.1 and D1.5

GATE A Submenu (Refer to Section 5.1.1)

- **GATE A START**—Sets the beginning position of A gate on the A-Scan.
- **GATE A WIDTH**—Sets the width of A gate on the A-Scan.
- **A THRESHOLD**—Sets the height of A gate on the A-Scan.
- **TOF MODE**—Indicates whether an A-Scan echo's flank or peak is evaluated by the A gate.

*JISDAC MENU**RECORD Submenu (Refer to Section 5.17.1)*

- **GATE A START**—Sets the beginning position of A gate on the A-Scan.
- **AUTO80**—Press and hold to automatically adjust applied gain to set the value of the highest peak in A gate to 80% of FSH.
- **RECORD**—Record the JISDAC reference point captured in A gate.
- **FINISH**—Complete the JISDAC reference point recording process.

GATE A Submenu (Refer to Section 5.1.1)

- **GATE A START**—Sets the beginning position of A gate on the A-Scan.
- **GATE A WIDTH**—Sets the width of A gate on the A-Scan.
- **A THRESHOLD**—Sets the height of A gate on the A-Scan.
- **TOF MODE**—Indicates whether an A-Scan echo's flank or peak is evaluated by the A gate.

SETUP Submenu (Refer to Section 5.17.2)

- **ISDAC**—Turns the feature on or off without deleting stored reference curves
- **BOLD LINE**—Indicates which JISDAC line (H, M, or L) to make bold on the display screen. Reference measurements are then made with respect to this bold line.
- **DELETE CURVE**—Deletes stored reference curves

MAT ATTN Submenu (Refer to Section 5.17.2)

- **TRANSFER CORR**—User input dB compensation for differences between standard and test coupling

4.5 Display Screen Features (Conventional)



The instrument’s display is designed to be easy to interpret. In Figure 47 on page 103 you’ll find an example of the a display configuration. This specific display includes the BASIC menu bar and DISPLAY submenu. Refer to this figure for an explanation of those screen features you’ll most often encounter.

Definition of Display Icons

There are several graphical features (icons) which appear in the display screen’s icon bar for various reasons. Figure 41 on page 93 includes several of these icons along with an explanation of their significance.

4.6 Initial Instrument Setup

In this part of the manual, you’ll learn how to configure the instrument’s display and operating features. Follow these procedures to turn it on and make initial adjustments to the instrument control settings. Because the instrument can be set to save the control settings when it’s turned off and restore them when it’s turned on, you won’t have to repeat these adjustments unless a change is required.

Turn on the instrument by pressing . First press  to select Conventional Mode. The Home Menu will be activated. This menu’s structure was shown in Figure 38 on page 81. Activate the Setup Menu by pressing  below it. Some submenus and functions from the Setup Menu are shown in Figure 42 on page 93.

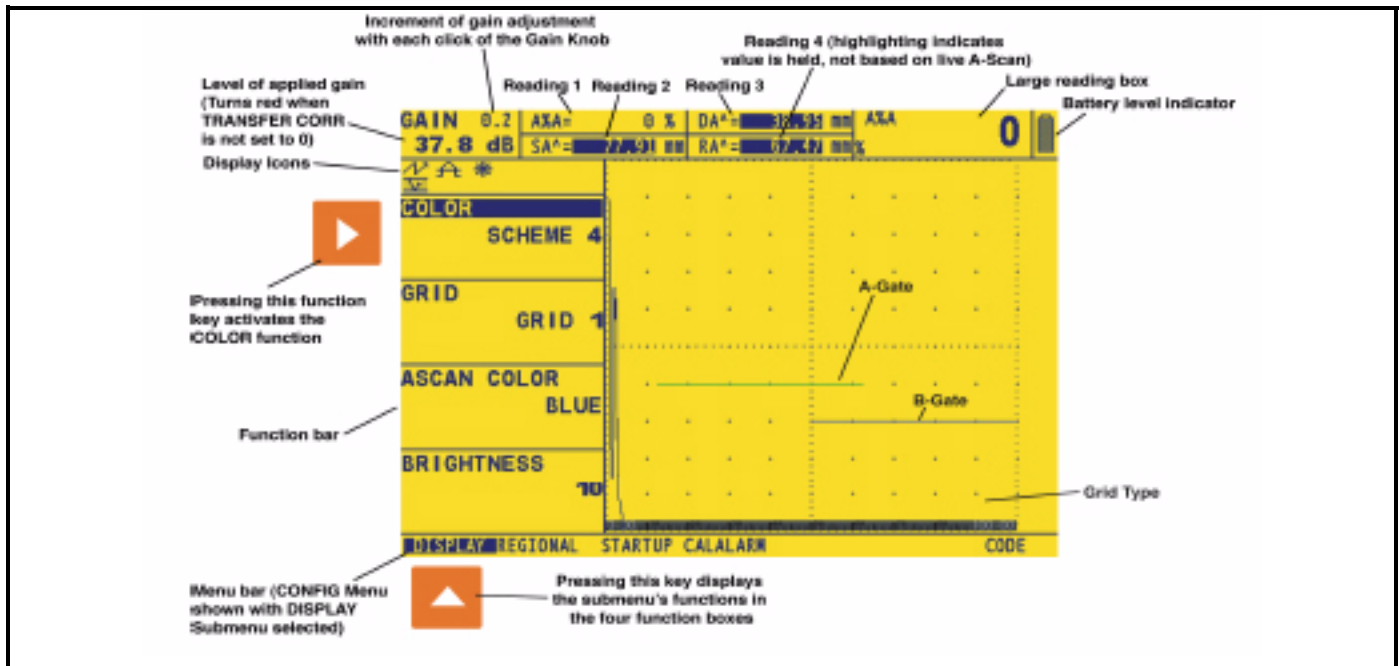

Figure 40: Display Screen Features

4.6 Initial Instrument Setup (cont.)

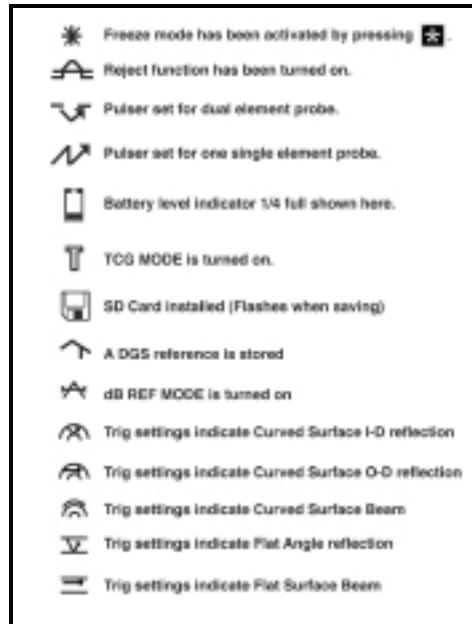

Figure 41: These icons appear on the display at various times.

4.6.1 Language, Units of Measurement, Date, and Time

Use the procedures below to adjust the unit of measurement, the date, the time, and the language that appears on the instrument's display screens and data output. The adjustments will require access to the REGIONAL and STARTUP Submenus. These are accessed from the CONFIG Menu (shown in Figure 42 below).

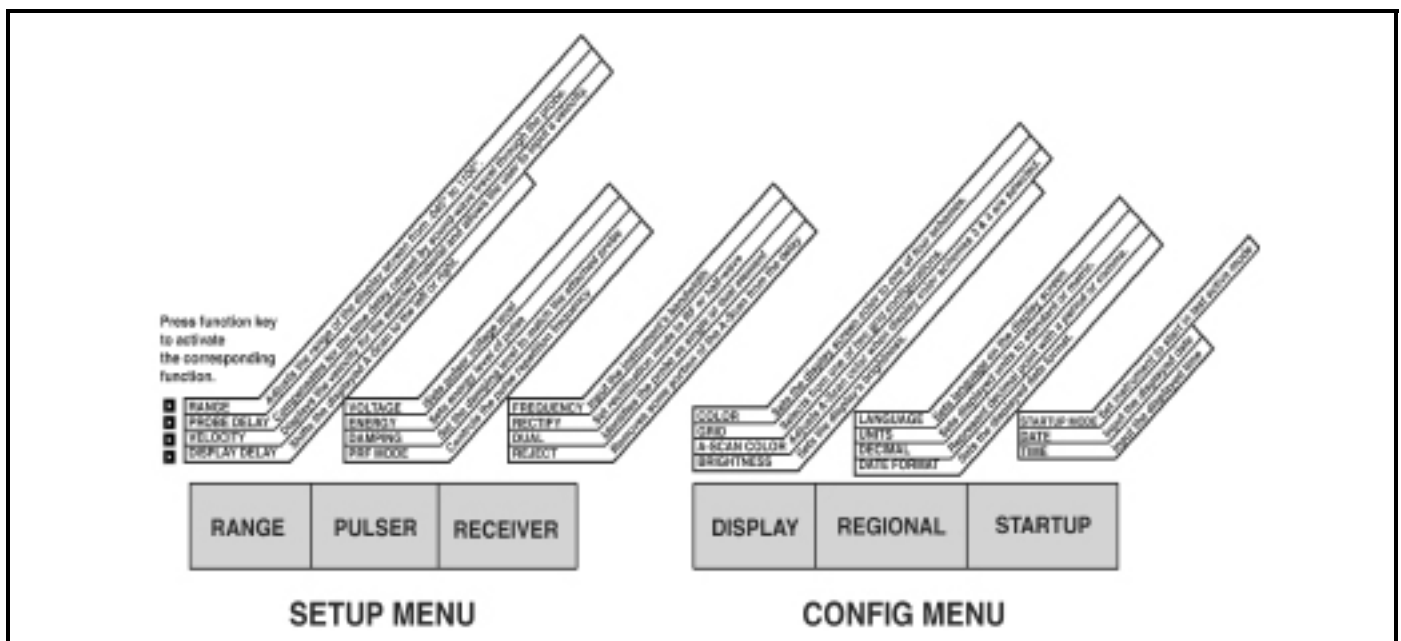







Figure 42: The CONFIG Menu allows the user to adjust most of the instrument's display and operating features. The SETUP Menu allows for pulser, receiver, and A-Scan adjustments.







Setting the Operating Language (CONFIG-REGIONAL-LANGUAGE)

1. Activate the REGIONAL Submenu (located in the CONFIG Menu) by pressing  below it. Four functions will appear down the left side of the display screen.
2. Press  next to the selection titled LANGUAGE. To change the selected language, continue pressing  or turn the function knob. You'll note that the options available are English, German, French, Spanish, Italian, Romanian, Polish, Czech, Russian, Japanese and Chinese. The default language is English.
3. The display-screen and report language will be set to the choice last selected.





Setting the Date and Time Formats (CONFIG-REGIONAL-DATE FORMAT)

1. Activate the REGIONAL submenu (located in the CONFIG Menu) by pressing  below it.
2. Press  next to the selection titled DATE FORMAT. To change the selected format, continue pressing  or turn the function knob. Choose from the following date and time formats:
 - Y-M-D (12 or 24 hour time format)
 - M/D/Y (12 or 24 hour time format)
 - D.M.Y (12 or 24 hour time format)
3. The date and time formats shown on the display-screen and in outputted reports will be set to the choice last selected.

Setting the Date (CONFIG-STARTUP-DATE)



1. Activate the STARTUP Submenu (located in the CONFIG Menu) by pressing  below it. Functions will appear down the left side of the display screen.
2. Press  next to the selection titled DATE. The date is displayed to show the Day, Month, and Year. Note that the first time you press , the day character is highlighted. The next time you press , the month character is highlighted. Finally, pressing  again will cause the year character to be highlighted.
3. To change the month, days, or year, turn the function knob while the desired character is highlighted.
4. When complete, press  one more time. The current date will be set to the date displayed.

Setting the Time (CONFIG-STARTUP-TIME)

1. Activate the STARTUP Submenu (located in the CONFIG Menu) by pressing  below it. Functions will appear down the left side of the display screen.
2. Press  next to the selection titled TIME. Time is displayed in 12 or 24-hour format. Note that the first time you press , the hours character is highlighted. The next time you press , the minutes character is highlighted.
3. To change the hours or minutes setting, turn the function knob while the desired character is highlighted.
4. When complete, press  one more time. The current time will be set to the time displayed.

Note: Once set, the internal clock will maintain the current date and time.



Setting the Units of Measurement (CONFIG-REGIONAL-UNITS)

1. Activate the REGIONAL Submenu (located in the CONFIG Menu) by pressing  below it. Functions will appear down the left side of the display screen.
2. Press  next to the selection titled UNITS. You'll note that the following options are available:
 - **•mm**—default setting which displays values in millimeters
 - **•INCH**— displays values in inches
3. To change the units of measurement, continue pressing  or turn the function knob.
4. The unit of measurement will be set to the choice last displayed.



4.6.2 Display Appearance

Use the procedures in this section to adjust display appearance. The adjustments will require access to the DISPLAY submenu, which is accessed from the CONFIG Menu (shown in Figure 42 on page 93).



Setting the Display Brightness (CONFIG-DISPLAY-BRIGHTNES)

1. Activate the DISPLAY Submenu (located in the CONFIG Menu) by pressing  below it. Functions will appear down the left side of the display screen.
2. Press  next to the selection titled BRIGHTNESS. Settings range from 1 to 10.
3. To change the brightness level, continue pressing  or turn the function knob.
4. The display brightness will remain at the level last displayed.



Selecting a Display Grid (CONFIG-DISPLAY-GRID)

1. Activate the DISPLAY Submenu (located in the CONFIG Menu) by pressing  below it. Functions will appear down the left side of the display screen.
2. Press  next to the selection titled GRID.
3. To change the grid type, continue pressing  or turn the function knob. Each grid style is shown in the display screen's A-Scan window as it is selected.
4. The grid style will be set to the last one displayed.

Setting the Display Color (CONFIG-DISPLAY-COLOR)

1. Activate the DISPLAY Submenu (located in the CONFIG Menu) by pressing  below it. Functions will appear down the left side of the display screen.
2. Press  next to the selection titled COLOR. There are four preset color schemes.
3. To change the display's color scheme, continue pressing  or turn the function knob.
4. The display color will remain at the scheme last displayed.

Setting the A-Scan Color (CONFIG-DISPLAY-ASCAN COLOR)

1. Activate the DISPLAY Submenu (located in the CONFIG Menu) by pressing  below it. Functions will appear down the left side of the display screen.
2. Press  next to the selection titled ASCAN COLOR. There are six A-Scan color options.
3. To change the A-Scan's color, continue pressing  or turn the function knob.
4. The A-Scan echo will remain the color last displayed.

4.7 Installing a Conventional Probe

4.7.1 Connecting a Conventional Probe

When connecting a conventional probe to the instrument, it's not only important that the probe's physical connection be properly made. It's also important that the instrument is properly configured to work with the installed probe. The instrument will operate in conventional mode with a single-element probe or with a dual-element probe.

To install a single-element probe, connect the probe cable to either of the two ports on the side of the instrument (Figure 43 below). When a dual-element probe is connected to the instrument, the "RECEIVE" probe connector should be installed in the top port and the "TRANSMIT" probe connector in the bottom port.

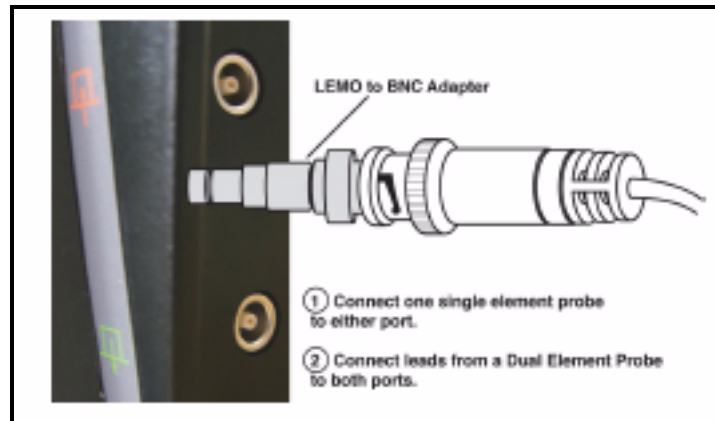







Figure 43: Probe Attachment Locations

4.7.2 Configuring the Instrument to Match the Probe Type



Three instrument settings are directly dependent on the type of probe installed. These settings must be adjusted any time a probe of a different type is installed.

IMPORTANT: *The Phasor XS may fail if a user removes or attaches the probe while the instrument is running. If this occurs, the user will lose any unsaved settings. To protect against this failure, GE recommends that the user power OFF the instrument before attaching or replacing a probe.*

Selecting Probe Type (SETUP-RECEIVER-DUAL)



1. Activate the RECEIVER Submenu (located in the SETUP Menu by pressing  below it).
2. Press  next to the selection titled DUAL.
3. To change the probe type, continue pressing  or turn the function knob. Each available probe type is represented by an icon that's displayed in the Icon Bar (near the upper left corner of the display) whenever that probe type is indicated. The following types are available:
 - ON—For dual-element
 - ( will be displayed)
 - OFF—For single-element probes ( will be displayed)
4. The probe type will be set to the last one displayed.

Specifying the Probe Frequency (SETUP-RECEIVER-FREQUENCY)

1. Activate the RECEIVER Submenu (located in the SETUP Menu) by pressing  below it.
2. Press  next to the selection titled FREQUENCY.
3. To change the specified frequency, continue pressing  or turn the function knob. You'll note that the following frequency settings are available:
 - **1, 2, 2.25, 4, 5, 10, 13 MHz**—Set to match conventional probe frequencies
 - **BROADBAND**—Select to utilize a built-in broad-band (BB) filter

The probe frequency level will be set to the last one displayed.

Modifying the Signal Ratio to Noise by Changing the Damping Level (SETUP-PULSER-DAMPING)

1. Activate the PULSER Submenu (located in the SETUP Menu) by pressing  below it.
2. Press  next to the selection titled DAMPING.
3. To change the specified damping level and optimize the A-Scan signal appearance, continue pressing  or turn the function knob. You'll note that the following damping levels are available:
 - **50 or 1000 Ω** (see Figure 44 below)

The damping level will be set to the one last displayed.

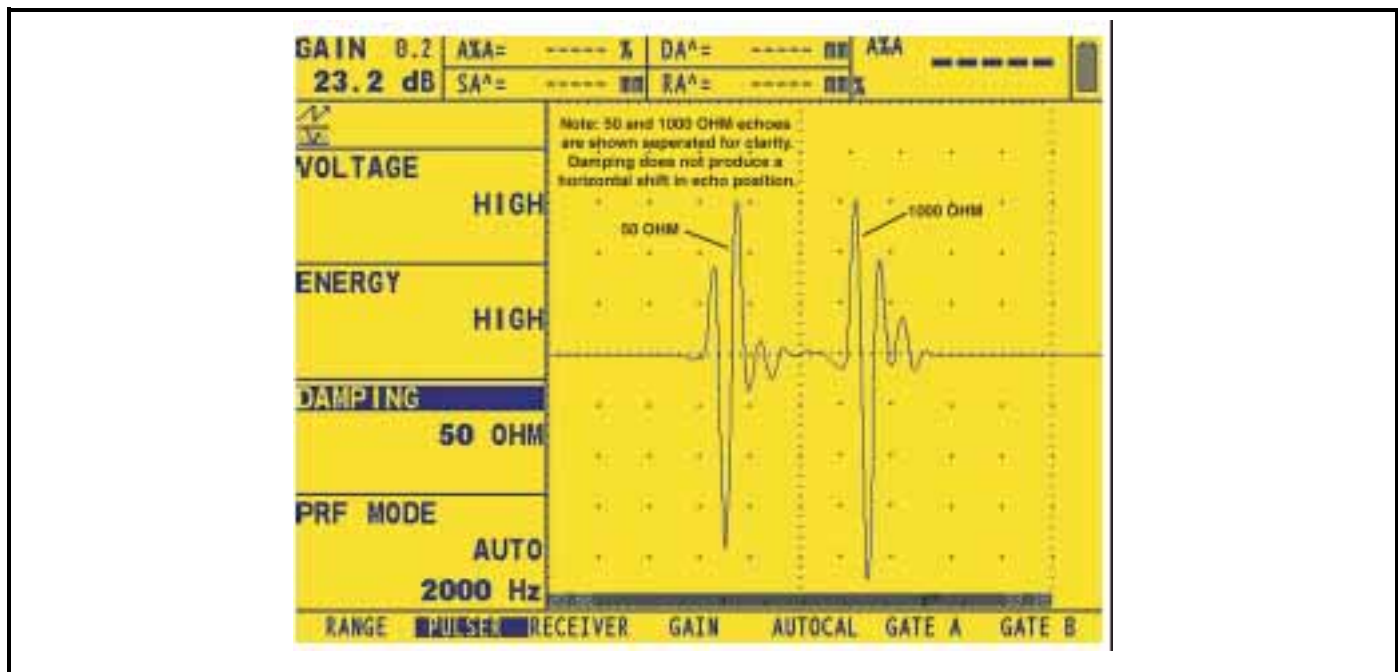





Figure 44: Typical Effects of Damping Changes

4.7.3 Adjusting the Pulser Repetition Frequency (PRF)

The Pulser fires at a frequency which can either be set automatically or manually. To set the PRF mode and frequency level

1. Activate the SETUP Menu (located in the HOME Menu) by pressing  below it.
2. Select the PULSER Submenu by pressing  below it. Two functions will appear down the left side of the display screen.
3. Press  next to the function titled PRF MODE. You'll note that there are two options:
 - AUTO—The instrument calculates and sets a pulser firing rate at 75% of the maximum frequency possible, based on range and material velocity.
 - MANUAL—allows the full range of PA PRF (minimum 20 to 20 kHz in 10 Hz steps), limited by the A-scan and gate range, FPGA timing, etc.

Note: The previous manual setting is not stored. In other words, if the user toggles to AUTO and back to MANUAL, the MANUAL value will be the “auto” value.

4. To manually set the Pulser Repetition Frequency, press  next to the function titled PRF MODE and set it to MANUAL. You may now adjust the PRF value by turning the function knob.
5. The automatically calculated value (if PRF MODE is set to AUTO) will be displayed in the function box.

Note: The PRF VALUE setting may be automatically limited based on the user-selected pulser voltage setting. This feature acts to limit signal dissipation.

4.7.4 Selecting a Rectification Mode



Rectification effects the orientation of the A-scan on the display screen. The A-scan represents the sound pulse (echo) that's returned from the material being tested to the instrument. The series of echoes looks like the *Radio Frequency (RF)* signal that's shown in Figure 44 on the previous page. Note that the RF signal has a negative component below the axis, and a positive component above the axis. In RF mode, the A-gate and B-gate can be positioned either above or below the axis, to be triggered by a positive-heading echo or a negative-heading echo.

Positive Half Rectification means that only the upper (positive) half of the RF signal is displayed.

Negative Half Rectification means that only the bottom (negative) half of the RF signal is displayed. In Figure 45 below, note that even though it's the negative half of the RF signal, it's displayed in the same orientation as a positive component. This is only to simplify viewing. The signal displayed in the view identified as Negative Reactance is the negative component of the RF signal.

Full-Wave Rectification combines the positive and negative rectified signals together, and displays both of them in a positive orientation (Figure 45).

Use the following procedure to select a rectification mode

1. Activate the SETUP Menu (located in the HOME Menu) by pressing  below it.
2. Select the RECEIVER submenu by pressing  below it. Four functions will appear down the left side of the display screen.
3. Press  next to the function titled RECTIFY (Figure 44). You'll note that there are four options:
 - **NEG HALFWAVE**—Shows the negative component of the RF signal but displays it in a positive orientation
 - **POS HALFWAVE**—Shows the positive component of the RF signal
 - **FULLWAVE**—Shows the positive and negative halves of the RF wave, but both are oriented in the positive direction
 - **RF**—Shows the echo with no rectification
4. Select the rectification method.

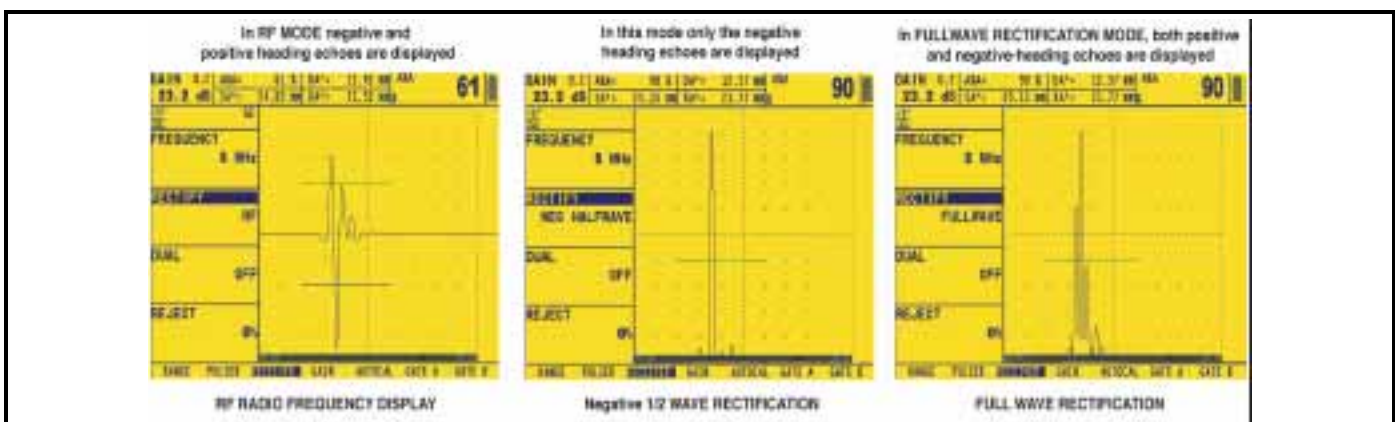





Figure 45: Rectification controls how much of the returned sound pulse appears on the display screen. Note that when RF rectification is selected, the A-Gate and B-Gate can be positioned above or below the axis.





4.7.5 Setting the Pulser Voltage or Energy Level

The relative energy with which the pulser fires is adjusted by changing the ENERGY and VOLTAGE settings. To set the pulser energy or voltage level:

1. Activate the SETUP Menu (located in the HOME Menu) by pressing  below it.
2. Select the PULSER Submenu by pressing  below it. Functions will appear down the left side of the display screen.
3. Set the ENERGY level to HIGH or LOW or press  next to the function titled VOLTAGE. Set a voltage level to HIGH or LOW.

4.7.6 Setting the A-Scan REJECT Level



A portion of the A-Scan can be omitted from the display screen. To omit a portion of the A-Scan, you must define the percentage of full-screen height you wish to omit. To set a reject percentage:

1. Activate the SETUP Menu (located in the HOME Menu) by pressing  below it.
2. Select the RECEIVER Submenu by pressing  below it. Four functions will appear down the left side of the display screen.
3. Press  next to the function titled REJECT.
4. To change the amount of A-Scan you wish to omit from the display screen (as a percentage of screen height) turn the function knob. You may omit A-Scans up to 80% of the screen height. Whenever REJECT is set to a value greater than 0%, the  will appear in the status bar.

4.8 Adjusting the A-Scan (Conventional)

4.8.1 Setting the A-Scan Range

Calibration requires the use of two calibrated standards, of different thickness, made of the same material as the test piece. Prior to calibrating the instrument/probe combination, the A-Scan display-screen range (the material thickness value represented by the full horizontal width of the screen) will normally be set to a value equal to or slightly larger than the thicker calibrated standard (Figure 46 on the next page).

1. Activate the Home Menu by pressing . Functions will appear down the left side of the display screen.
2. Press  next to the selection titled RANGE. You'll note that RANGE has both coarse and fine adjustment modes. Coarse and fine modes are selected by pressing  more than once. When "RANGE" appears in all capital letters, turning the function knob will produce large changes in the range value. When "range" appears in all lower-case letters, turning the function knob will change the value by smaller amounts.
3. To change the range turn the function knob. You'll note that the range can vary from 0.040 to 300 inches.

The display's horizontal range will remain as set.

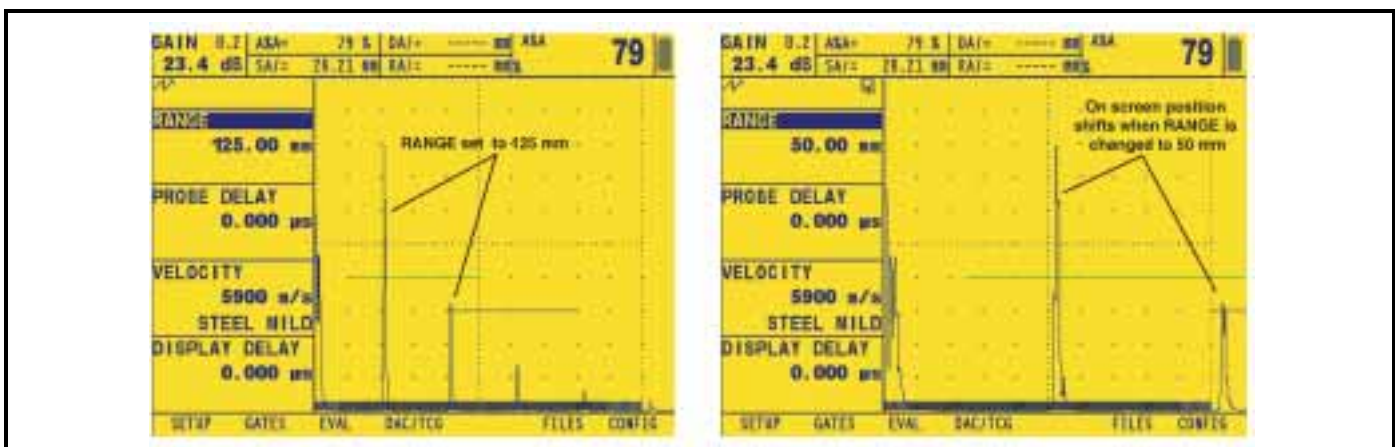



Figure 46: Effect of A-Scan Range Adjustment

4.8.2 Setting the Display Delay

The display delay function shifts the displayed A-Scan to the left or right. This function is used to set the instrument's viewing window. To set the display delay:

1. Activate the Home Menu by pressing . Functions will appear down the left side of the display screen.
2. Press  next to the selection titled DISPLAY DELAY.
3. To change the display delay turn the function knob. You'll note that the displayed echoes shift to the left or right.

4.9 Calibrating the Instrument

4.9.1 Pre-calibration Check List

To improve the accuracy and quality of your calibration, be sure that the following conditions are met before launching the calibration function:

- Probe installed
- DUAL (RECEIVER) setting must match probe
- Set the material type (Section 2.4)
- Recommended that DISPLAY DELAY be set to 0
- PRF set to AUTO.
- TCG—Turned OFF
- Recommended that REJECT be set to 0.

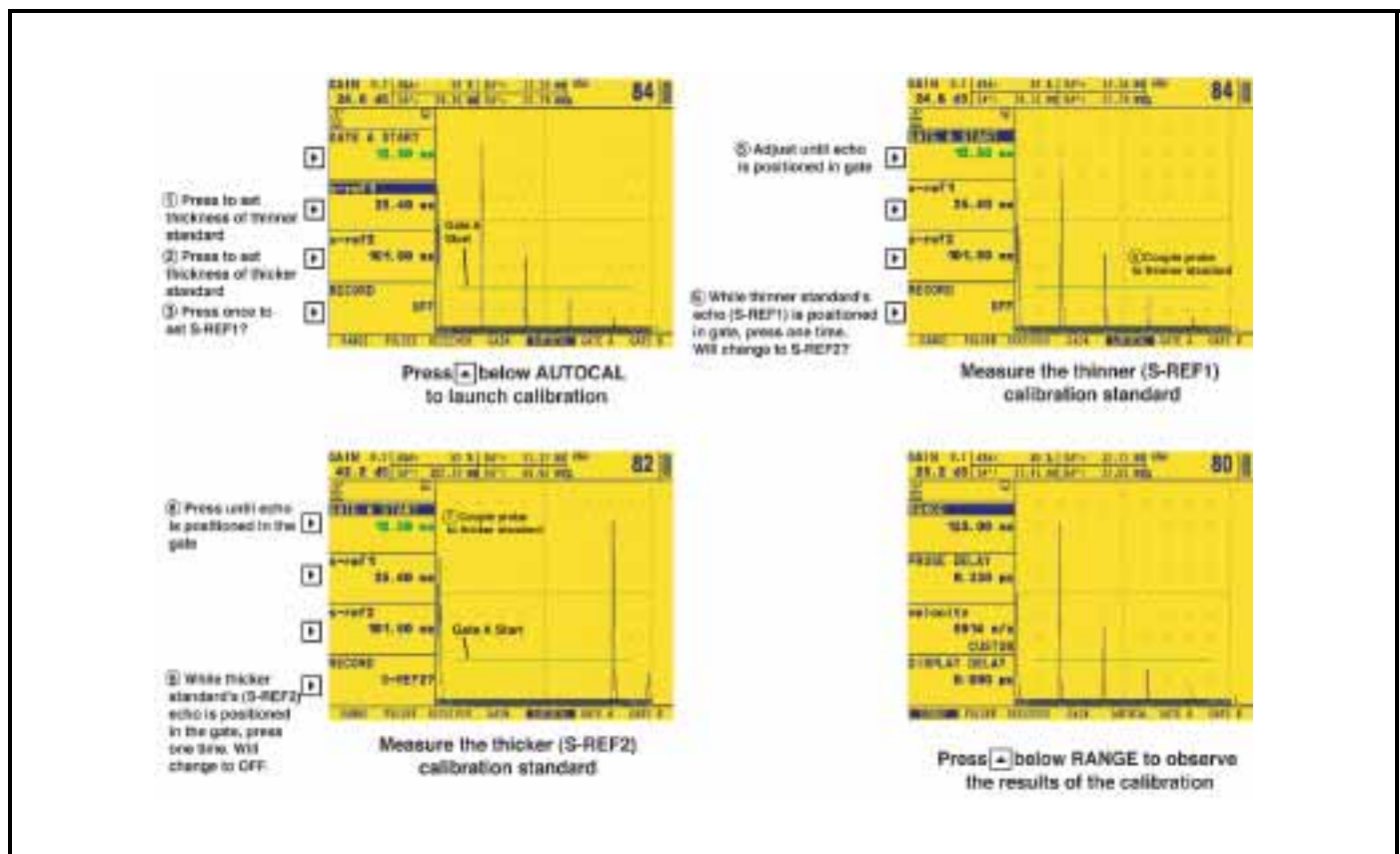







Figure 47: Auto Calibration Procedures

4.9.2 Using AUTOCAL to Calibrate the Instrument

(Read the following while reviewing Figure 47 on the previous page.)

1. From the SETUP Menu, activate the AUTOCAL Submenu by pressing  below it. Four functions will appear down the left side of the display screen.
2. Press  next to the selection titled S-REF1 and turn the function knob until the value of S-REF1 matches the thickness of the *thinner* calibration standard.
3. Press  next to the selection titled S-REF2 and turn the function knob until the value of S-REF2 matches the thickness of the *thicker* calibration standard.
4. Apply couplant and couple the probe to the thinner calibration standard. Press  next to the selection titled A START. Turn the function knob (this will shift the starting point of the A-Gate) until the A-Gate lies over the echo corresponding to the thinner standard's thickness (Figure 47).
5. Press  next to the selection titled RECORD. The value in the function box will change from "OFF" to "S-REF1?" Then go to the thicker standard's thickness and record value.

Note: The instrument's AUTOCAL Function applies only to conventional operation, not to phased-array operation.

Checking Calibration Results

Following the calibration procedure, the calculated acoustical velocity and probe delay are displayed. To view these calculated values, access the HOME Menu. You'll find these selections:

- **PROBE DELAY**—Adjustment made as a result of the AUTOCAL (zeroing) procedure. This represents the time delay caused by sound-wave travel through a probe's membrane, wear plate, or delay line.
- **VELOCITY**—Display's the calculated velocity after calibration. (Note that the material type is listed as custom.)



4.10 Using the Calibration Reminder Alarm

The instrument incorporates a timed alarm feature that causes an icon to appear on user input intervals between 0.5 and 4.0 hours. To use the alarm:

1. Access the CALALARM Submenu (located in the CONFIG Menu).
2. Use the REMINDER function to input the frequency at which the reminder alarm will trigger (between 0.5 and 4.0 hours). Setting this value automatically resets the alarm to trigger on the input frequency. This function also allows the alarm to be disabled.
3. Press  next to RESET to acknowledge the triggered alarm and reset it for continued operation. Note that the selection of PROBE DELAY or VELOCITY functions also resets the alarm.

4.11 Activating Instrument Upgrades

When provided, activation codes matched to your instrument's serial number can be input by using the CODE Submenu (located in the CONFIG Menu). This submenu also lists the serial number assigned to your instrument. To input an activation code:

1. Access the CODE Submenu (located in the CONFIG Menu).
2. Press  (two times) next to the CODE function to input the supplied activation code (see Chapter 6 to use the instrument's alphanumeric inputting feature).
3. Press  (two times) next to CONFIRM to acknowledge the input code is correct.
4. Be sure to follow on-screen instructions to press  for the activation to be successfully completed.



Chapter 5. Making Conventional Measurements

This chapter explains how to configure your instrument's conventional flaw detection and thickness measurement capabilities. It then explains how to make conventional measurements in CONVENTIONAL MODE. In this chapter, you'll learn how to:

- Adjust the A and B-Gates, alarms, outputs, and magnification ability (Section 5.1.1)
- Choose a Gate TOF MODE (peak or flank) (Section 5.1.2)
- Set Outputs and Alarms (Section 5.1.3)
- Configure the instrument for use of angle beam probes (Section 5.2)
- Identify which measured data to display in the RESULTS boxes (Section 5.3)
- Save the instrument's settings as a data set (Section 5.4)
- Lock the instrument's gain knob to prevent adjustment (Section 5.5)
- Adjust the instrument's gain setting (Section 5.6)
- Use the DAC/TCG evaluation modes to normalize A-Scan amplitudes regardless of the reflectors' depths (Section 5.8)
- Operate in DGS evaluation mode (Section 5.14)
- Operate in dB REF evaluation mode (Section 5.15)
- Operate in AWS D1.1 / 1.5 evaluation mode (Section 5.16)
- Operate in JISDAC evaluation mode (Section 5.17)

5.1 Configuring the A and B-Gates

Setting the position and characteristics of the A and B-Gates is the first step to configuring the instrument for conventional flaw detecting or material-thickness measurement. The GATES menu controls not only the location of the A and B-Gates, but also the alarms and other features activated when an A-Scan signal crosses a specific gate.

First press  and select CONVENTIONAL MODE, then press . From the Home Menu, activate the Gates Menu by pressing  below it. The submenus and functions available in the Gates Menu are shown in Figure 48 below.

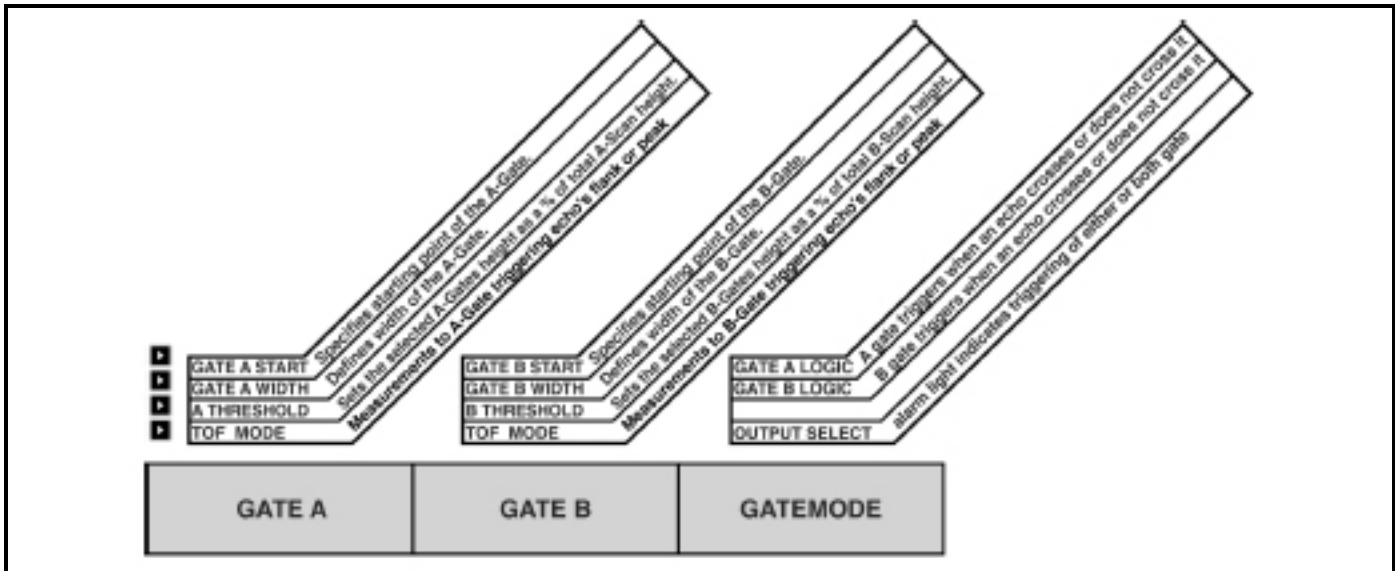

Figure 48: The Gates Menu allows the user to position and otherwise configure the instrument's gates.

5.1.1 Positioning Gates

Use the following procedures to set the vertical and horizontal position of the A Gate and B-Gate. The effect of each gate-positioning function is shown in Figure 49 on page 109. Remember that gate position has the following effects on instrument performance:

- A-Scan echos on the right side of the display screen represent features that occur at a greater depth from the test-material surface than those on the left of the display screen. Therefore, moving a gate to the right means that the gate is evaluating a deeper portion of the test material.
- A wider gate will simply span the equivalent of more test-material depth.
- Increasing the vertical height (called threshold) of a gate means that only reflected signals of sufficiently large amplitude will cross the gate.

Setting a Gate's Starting Point (GATES-GATE A or GATE B-GATE START)

1. Activate the GATE A or GATE B Submenu (located in the GATES Menu).
2. Select the GATE A or B START function and adjust the starting point by turning the Function Knob. Increasing and decreasing the value of the starting point moves the gate to the right and left, respectively.
3. The gate starting point will remain as set, even when width adjustments are made.

Adjusting a Gate's Width (GATES-GATE A or GATE B-GATE WIDTH)

1. Activate the GATE A or GATE B Submenu.
2. Select the GATE A or B WIDTH function and adjust by turning the Function Knob.

Setting a Gate's Threshold (Vertical Position) (GATES-GATE A or GATE B-A or B THRESHOLD)

1. Activate the GATE A or GATE B Submenu.
2. Select the A or B THRESHOLD function and adjust the vertical height by turning the Function Knob. Increasing and decreasing the value of the threshold moves the gate up and down, respectively.

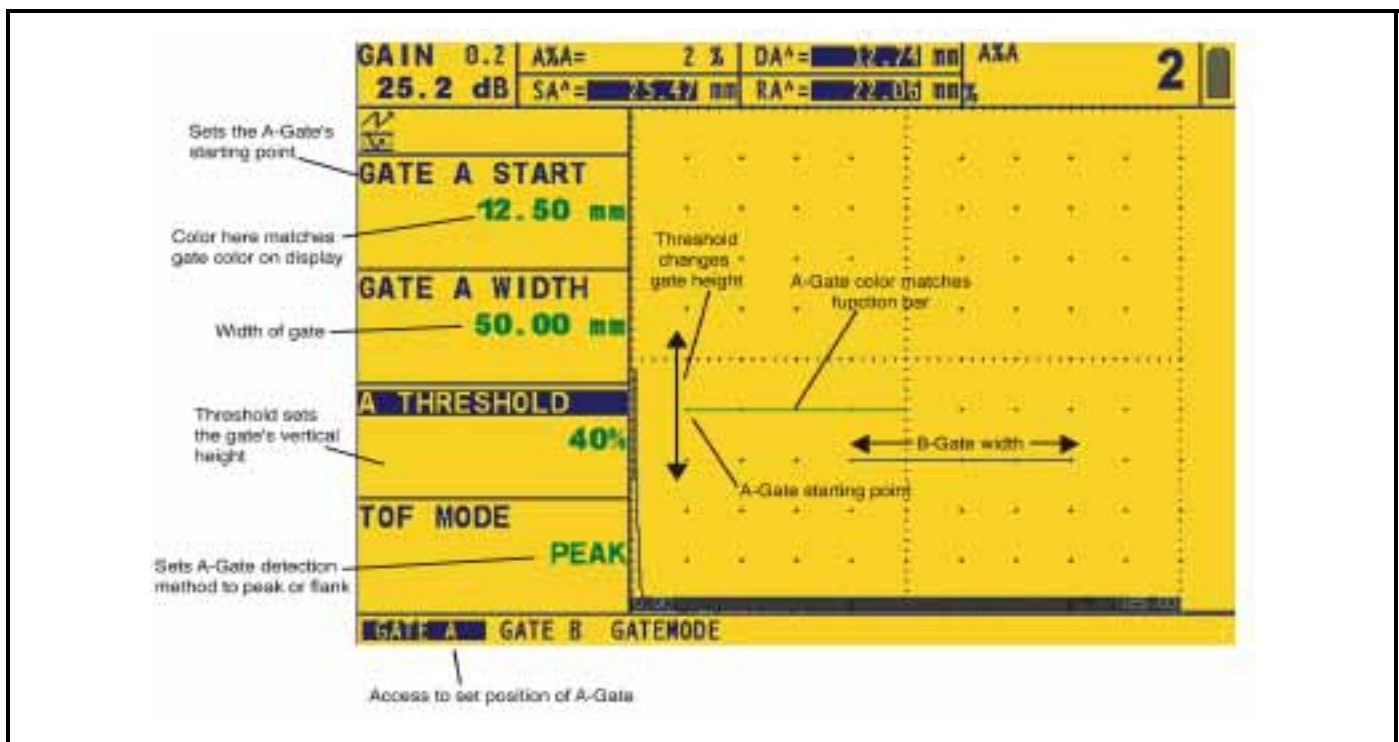

Figure 49: Gate position and width can be adjusted as shown here.

5.1.2 Selecting the TOF-Detection Method

A-Scan signals crossing the A or B-Gate are evaluated for the purposes of flaw detection and material-thickness evaluation. When the signal crosses the A or B-Gate, either the gate-crossing point (flank) of the signal, or the maximum point (peak) of the signal (in the specific gate) is used for evaluation purposes. The TOF MODE function allows the user to specify which A-Scan feature (FLANK or PEAK or JFLANK) is used to evaluate the signal in each gate. See Figure 50 below.

1. Activate the A GATE or B GATE Submenu (located in the GATES Menu).
2. Select the TOF MODE function and choose between FLANK, PEAK, and JFLANK methods.

PEAK—All detection (time-based and peak height) is based on the HIGHEST triggering echo in the gate.

FLANK—Time-based triggering point is the first flank to cross the gate and amplitude-based results are based on the HIGHEST peak of any echo crossing the gate (NOT necessarily the peak of the echo whose flank triggered the gate).

JFLANK—Time-based triggering point is the first flank to cross the gate and amplitude-based results are based on the peak of this first echo to cross the gate (even if it is NOT the highest echo in the gate).

Note: The detection method chosen will be reflected by a small icon. This icon is displayed in the display box containing the measured reading, and in the options offered in the READING 1 through 6 function boxes (see Figure 52).

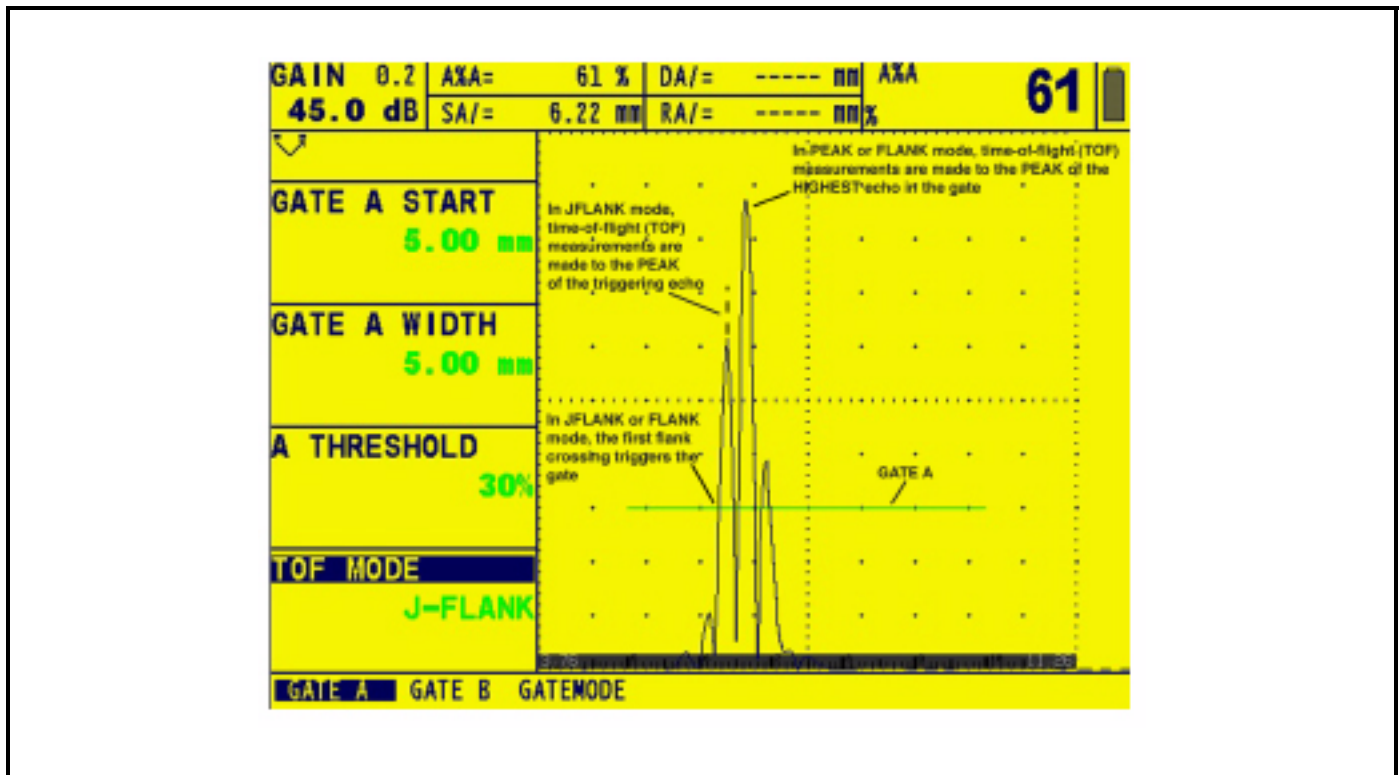

Figure 50: Setting Gate TOF Detection Mode

5.1.3 Setting Gate Alarms and Outputs

An alarm can be set at either or both of the gates. When a gate alarm is activated, an indication light on the front of the instrument will illuminate and a signal can be output.

Defining Gate-Alarm Logic (GATES-GATE MODE-GATE A or B LOGIC)

Each gate's alarm can be triggered under one of two circumstances. Gate alarms can be set to trigger when an A-Scan echo crosses the gate or when *no* echo crosses the gate. Use the following procedure to specify gate LOGIC settings:

1. Activate the GATE MODE Submenu (in the GATES Menu).
2. Select the GATE LOGIC function you wish to specify.
3. Choose the gate-alarm triggering logic:
 - POSITIVE—An A-Scan signal crosses the gate
 - NEGATIVE—No A-Scan signal crosses the gate
 - OFF—No alarm will be connected to the selected gate

Note: A- and B-Gates can be configured so that either triggers the alarm.

Assigning Outputs / Alarm Indication Lights to Gates (GATES-GATE MODE-OUTPUT SELECT)

A warning light appears on the front of the instrument (see Figure 37 on page 80 for light location). This light corresponds to an OUTPUT, which is in-turn assigned to a gate alarm. When an alarm is triggered, a warning light illuminates (except when the GATE LOGIC is set to OFF). Use the following procedure to indicate which gate activates the light:

1. Activate the GATE MODE Submenu (in the GATES Menu).
2. Select the OUTPUT SELECT Function.
3. Choose one of the following selections:
 - A-GATE—Alarm light indicates when A-Gate's alarm triggers
 - B-GATE—Alarm light indicates when B-Gate's alarm triggers
 - A or B—Alarm light indicates when either A or B Gate's alarm triggers

Select Gate to Be Magnified when BVIEW Is Pressed (EVAL-EVAL MODE-MAGNIFY GATE)

Pressing  magnifies the A-Scan display so the assigned gate spans the entire displayed range. To specify the gate that should be magnified on demand:

1. Activate the EVAL MODE Submenu (in the EVAL Menu).
2. Choose the MAGNIFY GATE function.
3. Select GATE A or GATE B.

Note: Pressing BVIEW magnifies the display so the selected gate spans the entire displayed range.

5.2 Using Angle Beam Probes and the TRIG Menu

When connecting an angle beam probe to the instrument, adjustments must be made for probe characteristics as well as test-piece geometry. These features are shown in Figure 51 below and include

- Probe Angle
- Probe's X value (distance from the probe's Beam Index Point (BIP) to the front edge of its wedge.)
- Test-piece thickness

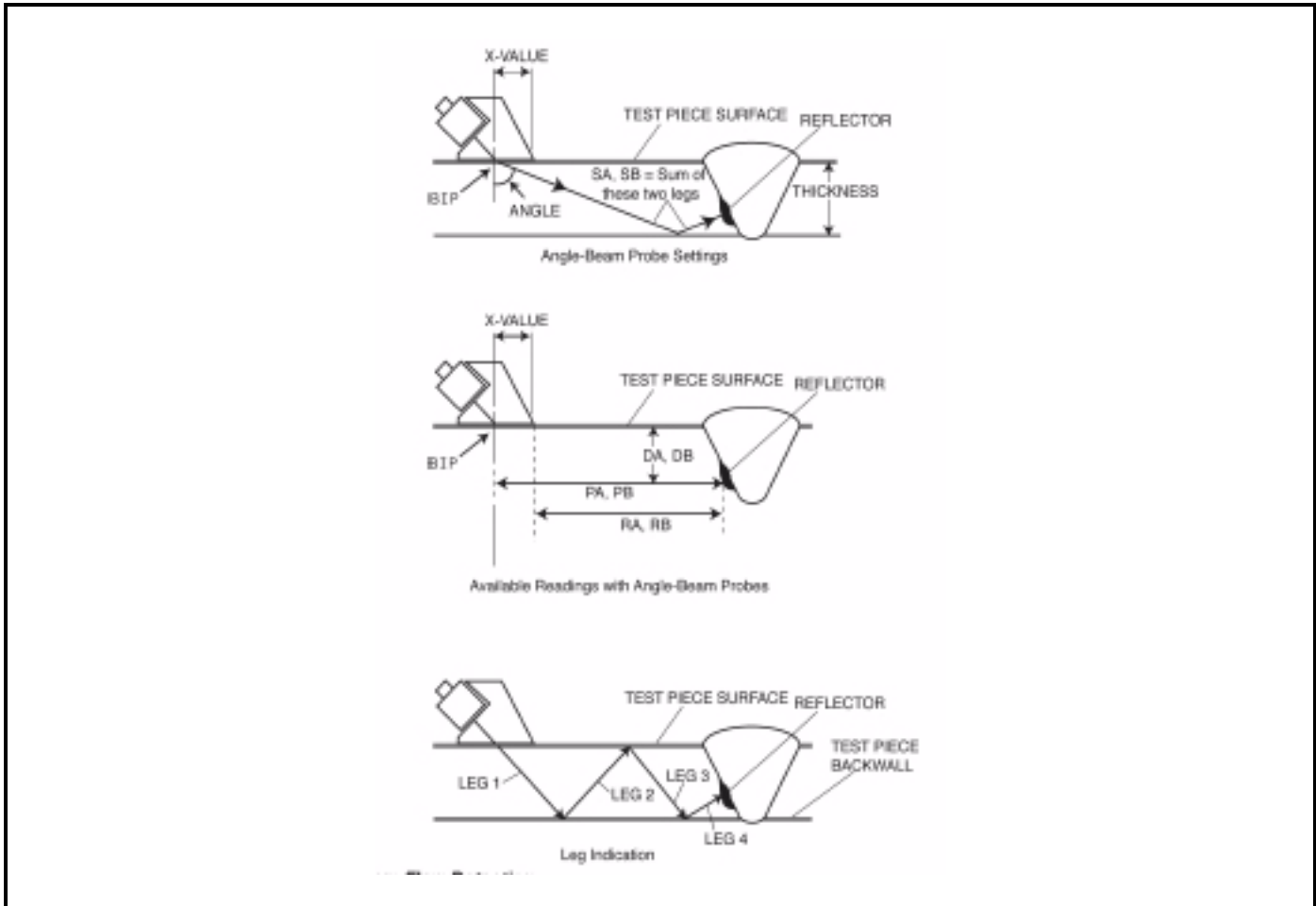

Figure 51: Angle Beam Flaw Detection

5.2.1 Setting Angle Beam Probe Characteristics

To configure the instrument for an angle-beam probe, follow this procedure

1. Activate the TRIG Submenu located in the EVAL menu.
2. Select the PROBE ANGLE function and input the angle for the probe you've installed. Surface evaluation is performed by installing the correct probe/wedge and setting this value above 89 degrees.
3. Select the THICKNESS function and input the thickness of the test piece. Note that the thickness of a solid rod is input as ONE-HALF of its diameter (which means that the THICKNESS value will equal one-half of the O DIAMETER value).
4. Select the X VALUE function and input the user-determined X value for the probe. When desired, this compensates for the distance from the BIP to the front of the probe's wedge.
5. Select the O DIAMETER function and input a curved test piece's outside diameter (from 50 to 2000 mm). When set to FLAT, curvature correction is not applied.

Note: Based on the values input for the TRIG functions (PROBE ANGLE, THICKNESS, X VALUE, and O DIAMETER), the instrument operates in one of five modes. Each of these modes are represented by an icon in the ICON BAR located near the screen's upper left corner. See Figure 41 on page 93 for interpretation of these icons.

5.2.2 Indicating Leg with Color

The leg in which a reflector is encountered, as identified in Figure 51 on the previous page, can be visually indicated on the instrument display using color. Setting the COLOR LEG function (located in the EVAL MODE submenu of the EVAL Menu) to ON will cause each ultrasonic time region to be displayed in a unique color.

5.3 Displaying Measured Results

The instrument is capable of displaying up to six measured readings at one time. The displayed readings are selected using the RESULTS Submenu located in the EVAL Menu. Parameters available for display include the following (availability depends on instrument configuration and operating mode):

- A%A—Amplitude (as a % of full-screen height) of the highest echo falling within the width of A-Gate
- A%B—Amplitude (as a % of full-screen height) of the highest echo falling within the width of B-Gate

Note: When S, D, P, or R readings are displayed, the Gate-Detection Mode (5.1.2) setting for the referenced gate (A or B) is indicated by a ^ (Peak Mode) or a / (Flank Mode).

- SA—Sound-Path distance or duration represented by the highest echo to cross A-Gate
- SB—Sound-Path distance or duration represented by the highest echo to cross B-Gate
- SBA—Sound-Path distance or duration from the highest echo in A-Gate to the echo in B-Gate. Reading is only available if B-Gate and A-Gate are on.
- DA—Material-thickness depth from the test-piece surface (the probe-contacted side) to the reflector represented by the echo in A-Gate. (see Figure 51 on page 112)
- DB—Material-thickness depth from the test-piece surface (the probe-contacted side) to the reflector represented by the echo in B-Gate. (see Figure 51 on page 112)
- LA—Leg number of the reflector represented by the echo in A-Gate. (see Figure 51 on page 112)
- LB—Leg number of the reflector represented by the echo in B-Gate. (see Figure 51 on page 112)
- PA—Projection distance from the probe's BIP to the reflector represented by the echo in A-Gate. (see Figure 51 on page 112)
- PB—Projection distance from the probe's BIP to the reflector represented by the echo in B-Gate. (see Figure 51 on page 112)
- RA—Projection distance from the probe's BIP to the reflector represented by the echo in A-Gate, *minus* the inputted X-VALUE. (see Figure 51 on page 112)
- RB—Projection distance from the probe's BIP to the reflector represented by the echo in B-Gate, *minus* the inputted X-VALUE. (see Figure 51 on page 112)
- A%rA—Amplitude of the signal crossing the A-Gate as a percentage of the active EVAL MODE's reference amplitude.
- dBrA—dB equivalent height *difference* between the signal crossing A-Gate and the active EVAL MODE's reference height.
- A%rB—Amplitude of the signal crossing the B-Gate as a percentage of the active EVAL MODE's reference amplitude (see below).
- dBrB—dB equivalent height difference between the signal crossing B-Gate and the active EVAL MODE's reference height (see below).

Reference results (identified with "r") Behavior Based on EVAL MODE

- DAC—% Amplitude or dB compared to corresponding DAC curve point
- TCG—% Amplitude or dB compared to TCG reference level
- dB REF—% Amplitude or dB compared to reference level
- DGS—% Amplitude or dB compared to curve/size selected
- JISDAC—% Amplitude or dB compared to JIS LINE (H, M, or L) set to BOLD
- NONE—% Amplitude or dB compared to gate threshold height
- CLS—JIS CLASS (I, II, III, or IV) available only when JISDAC evaluation mode is active.
- ERS—Evaluates the reflected echo (DGS Mode) and calculates the Equivalent Reflector Size
- Gt—DGS test gain, which initializes the DGS curve's max height at 80% FSH.
- Gr—DGS reference gain, which represents the instrument gain at which the reference echo's peak reaches 80% FSH.
- OFF—No reading will be displayed in the reading box.

The measured readings can be displayed in any of the up-to-six small reading boxes at the top of the display screen. Note that when four small results are shown, another result can be displayed in the large reading box (see Figure 52 on the next page).

The large result box can also be split into two smaller boxes, allowing up to six results to be displayed simultaneously:

1. Access the RESULTS2 Submenu (located in the GATES Menu).
2. Determine the configuration of the large display box by setting the MODE function to either LARGE (one parameter displayed) or SPLIT (two parameters displayed in smaller boxes).
3. Access and set the READING 5/LRG and READING 6 functions to select the desired result(s) to be displayed.

Also note that when time or thickness readings are displayed, the detection method selected for that gate is indicated with a ^ (representing PEAK) or / (representing FLANK or JFLANK). See Section 5.1.2 to select detection methods.

Note: Under certain conditions, while TCG reference points are being recorded, two measurement results boxes will be automatically set (if not already configured) to display SA and A%A values.

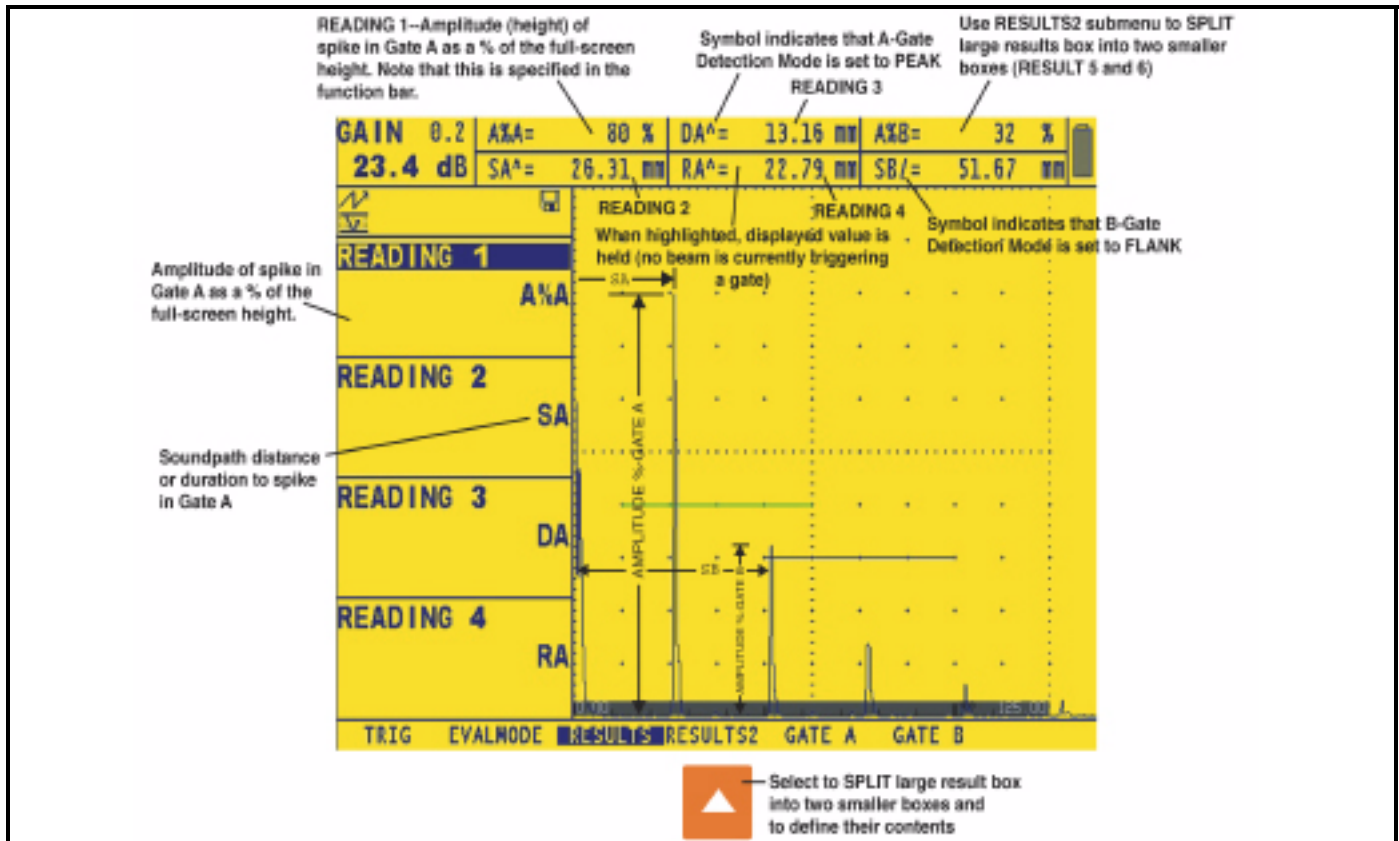

Figure 52: The RESULTS submenu is used to specify which measured values to display.

5.4 Saving the Instrument Configuration in a Data Set

Instrument settings can be stored as Data Sets. Those functional settings that are saved within a data set are shown in Section 6.1. When a stored data set is later recalled, all active functional settings are replaced with those settings contained in the data set, and the stored A-Scan (if stored with data set) is displayed and frozen on the display screen. Once a data set is recalled, the newly active functional settings may be modified. Anytime that data set is recalled, the functional settings will be returned to their initially stored values. The operating parameters of a stored/recalled data set can be modified by making the necessary changes after recalling, then selecting STORE DATASET under the ACTION function and activating, then confirming, the changes.

See Section 6.1.1 to create a data set file.

5.5 Locking the Gain Rotary Knob

The gain knob can be locked so that turning it has no effect on the instrument.

1. Continue pressing  while observing that the value of dB STEP (in the upper left-hand corner of the display) changes to various gain increment values. When the word LOCK appears as the dB STEP value, the gain knob is locked.
2. To unlock the knob, change the setting of dB STEP to some value other than LOCK.



Note: The gain knob is automatically locked whenever the knob emulator menu is activated by pressing .

5.6 Setting the Gain

Instrument gain, which increases and decreases the height of a displayed A-Scan, is adjusted with the Gain Knob. The instrument's gain can be adjusted while in any menu location except when the dB STEP feature is set to LOCK.



5.6.1 Changing the Gain-Adjustment Increment (dB STEP)

When adjusting the A-Scan gain, each click of the gain-adjustment knob increases or decreases the gain level by a dB increment equal to the dB STEP. Several values can be specified for dB STEP, including a user-specified gain step, known as the USER GAIN STEP, and a Gain knob adjustment LOCK, which prevents any gain adjustment. To select one of the existing dB STEP values:



1. Press .
2. Note that the dB STEP (gain-adjustment increment) value, as labeled in Figure 39 on page 87, changes as you continue to push . Available increments include: 0.2 dB, 0.5 dB, 1.0 dB, 2.0 dB, 6 dB, a user-defined Gain Step (if one has been defined), and LOCK. To specify a user-defined dB STEP value, see the next manual procedure. Note that setting the dB STEP to LOCK prevents adjustment of the instrument gain.
3. Once a dB STEP value has been selected, each click of the Gain Knob will increase or decrease the instrument's gain by the dB STEP increment.

5.6.2 Setting the User-Defined Gain Step (SETUP-GAIN-USER GAIN STEP)

When adjusting the A-Scan gain, each click of the gain-adjustment knob increases or decreases the gain level by the amount of the dB STEP (see above for adjusting the dB STEP). Several values can be selected for dB STEP, including a user-specified gain step, known as USER GAIN STEP. To input a user-specified gain step:

1. Activate the GAIN Submenu (located in the SETUP Menu) by pressing  below it. Functions will appear down the left side of the display screen.
2. Press  next to the selection titled USER GAIN STEP.
3. To set the USER GAIN STEP size, continue pressing  or turn the function knob.

5.7 Freezing the A-Scan Display

Whenever an A-Scan is active, pressing the freeze key () freezes the A-Scan display. The active A-Scan will remain as it appeared when  was pressed and the display will remain frozen until  is pressed again.

While the display is frozen, the displayed readings are based on the frozen echoes.

5.8 DAC/TCG Evaluation Mode

Note: Result-evaluating features, such as DAC/TCG, are first selected via the EVAL MODE function (located in the EVAL Menu). The selected evaluation feature's menu then appears in the HOME Menu.

Conventional measurements can be made using the Time Corrected Gain (TCG) and Distance Amplitude Correction (DAC) functions (Figure 53 below). These functions are accessed through the DAC/TCG Menu on the HOME Menu bar. Both the DAC and TCG functions operate based on a set of user-recorded data points. These points are recorded from the DAC/TCG menu as described below.

The TCG function displays reflectors of equal size at equal A-Scan amplitudes, regardless of the reflector's depth in the test material. This is accomplished by adjusting the gain at different locations in the A-scan display, corresponding to different material depths, to compensate for signal loss (or variation) due to attenuation, beam spread, or other factors.

When TCG is activated,  appears in the status bar near the top right-hand corner of the display.

The DAC function displays all echoes at their true amplitude (without depth compensation). However, when operating in DAC mode, a Distance Amplitude Correction curve is superimposed on the A-Scan display. The curve, like the one shown in Figure 53 below, represents constant reflector size at varying material depth.

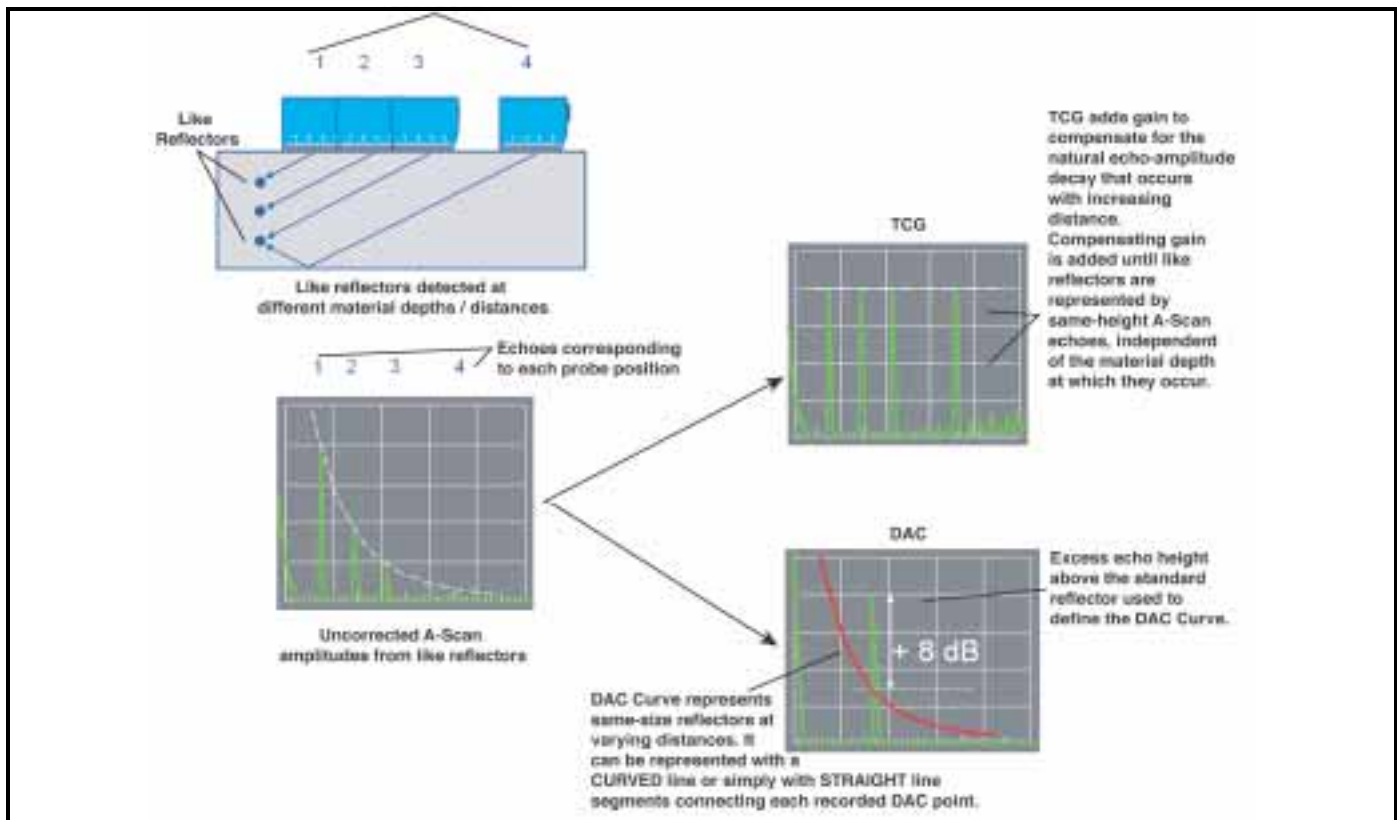

Figure 53: Distance/Time Compensation Features

5.9 Using DAC



When displayed, the DAC curve visually represents a line of constant reflector peaks over a range of material depths. Remember that in DAC mode, the only deviation from traditional display and operation is the appearance of the DAC curve. All A-Scan echoes are displayed at their non-compensated height. A DAC curve can be based on up to 15 data points (material depths).

A DAC curve is programmed using a series of same-reflector echoes at various depths covering the range of depths to be inspected in the test material. Because near field and beam spread vary according to transducer size and frequency, and materials vary in attenuation and velocity, DAC must be programmed differently for different applications.

The dynamic range of the DAC function is 60 dB. Maximum curve slope is 12 dB per microsecond. Successive data points do not have to decrease in amplitude. That is, the DAC/TCG curve does not have to have a constantly descending slope.

5.9.1 Recording the DAC Curve

DAC Curve points are typically recorded from a standard with equally sized reflectors (holes) located at various material depths. The primary echo from each of these points (for up to a total of 15 echoes) are recorded. When DAC is active, the instrument displays a line that represents echo peaks for constant reflectors at varying material depth. This line is drawn as either a curved (linear in gain) line based on a series of collected DAC points or a series of straight line segments that join these DAC points. Only one DAC curve can be stored at a time. To program the DAC Curve:

1. Access the DAC/TCG menu by pressing  below it. The RECORD Submenu will be selected.
2. Couple the probe to the first reference point and, using  next to GATE A START and A THRESHOLD, adjust the A-Gate so that it is broken by the primary echo. If necessary, use the Gain Knob to adjust the gain so that the echo crosses the A-Gate and the highest peak in gate A is at approximately 80% of full-screen height. The highest peak must not be higher than 100% full-screen height.

Note: The AUTO 80 function allows for automatic application of gain to set A-Gate's triggering echo to 80% of full screen height. Press  to select AUTO 80 (located in the RECORD Submenu), then press and hold it again.

This function can also be accessed at any time via the knob emulator menu (activated by pressing ).

3. While the Gate is lined up over the first reference echo, press  next to the RECORD function. When the value of the RECORD function changes from 0 to 1, you have recorded the first DAC Curve point. Note that the first DAC point is treated as the reference echo. The amplitude value at which this point is recorded becomes the "reference amplitude" value.

Note: When the first DAC reference point is stored, two measurement result boxes will be automatically set (if not already configured) to display SA and A%A values.

4. Continue to record additional Curve points, following steps 2 and 3, up to a maximum of 15 points (note that at least two DAC Curve points are required).
5. When complete, press  next to FINISH.
6. The DAC curve can appear as a series of straight line segments that join the stored DAC points or as a curved (linear in gain) line that's based on these points. Access the DAC TYPE function, located in the SETUP Submenu, to display the desired DAC curve type.

5.9.1 Recording the DAC Curve (cont.)

Note: Stored DAC Curve points can be edited as described in Section 5.1.

Note: The DAC curve and status (OFF, TCG, or DAC) will be stored with the data set. When recalled, curve status will be the same as when it was stored. For example, if DAC is active when a data set is stored, it will be active when that data set is recalled.

5.9.2 Working with DAC

In DAC mode, the instrument uses the user-input reference points to create a curve representing the amplitudes of echoes representing same-size reflectors at varying material depth (Figure 53 on the previous page). The recorded reference point data is stored until replaced or edited. To create a DAC curve and operate in DAC mode:

1. With the DAC/TCG Menu accessed, select the SETUP submenu.
2. Press  next to the TCG/DAC MODE function until DAC appears. The DAC Curve will appear whenever operating in DAC mode.
3. The DAC curve can appear as a series of straight line segments (Figure 54) joining the stored DAC points or as a curved (linear in gain – as shown in Figure 53) line that's based on these points. Access the DAC TYPE function, located in the SETUP Submenu, to display the desired DAC curve type.

Note: To operate in TCG/DAC mode, a DAC curve must first be generated. After the DAC curve is generated, the TCG feature can be accessed by setting the TCG/DAC function's value to TCG.

Note: When rectification is set to RF, reference lines are not displayed.

5.10 Using TCG

When the TCG function is in use, echoes from equally sized reflectors appear as the same height on the A-Scan display.

When operating in TCG mode, **T** will appear on the display screen. Before using the TCG function, do the following:

1. The instrument/probe combination has been calibrated and all instrument settings (PULSER, RECEIVER, etc.) have been made. Changing these settings after the TCG reference points are input will affect the accuracy of measurement.
2. TCG reference points (up to 15) must be recorded. This process allows the instrument to calculate and compensate for the effect on material depth on reflector-echo height. The dynamic range of the TCG function is 60 dB. Maximum curve slope is 6 dB per microsecond. Successive data points do not have to decrease in amplitude. That is, the DAC/TCG curve does not have to have a constantly descending slope.

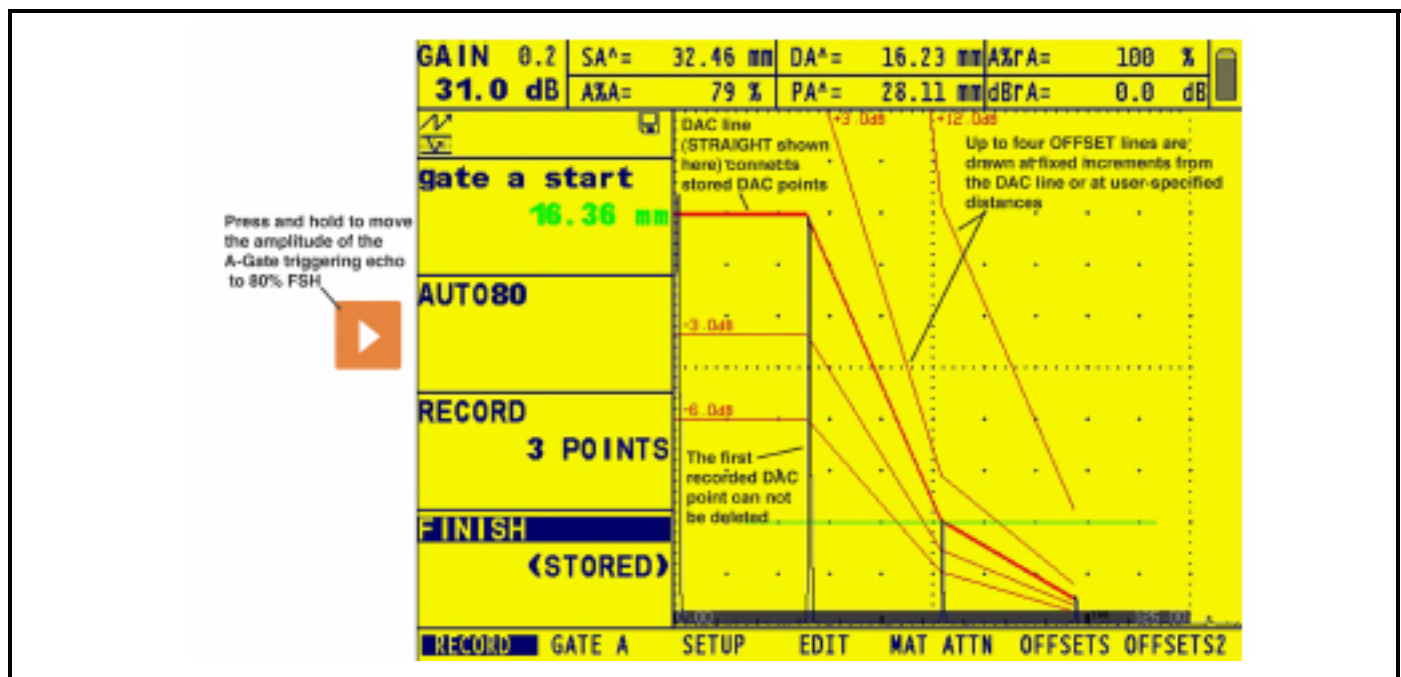

Figure 54: Storing at least two DAC points allows you to generate a curved or straight (shown here) DAC line and corresponding offset lines.



5.10.1 Generating the TCG Reference Curve

TCG reference points are derived from the points used to create the DAC curve. Points are typically taken from a standard with equally sized reflectors (holes) located at various material depths. The primary echo from each of these points (for up to a total of 15 echoes) are recorded. When TCG is active, the instrument compensates for different material thickness by applying a varying gain level to echoes at material depths other than the baseline depth. Only one DAC curve can be stored at a time.

Note: TCG reference points, curve, and status (OFF, TCG, OR DAC) will be stored with a data set. When recalled, curve status will be the same as when it was stored. For example, if TCG is active when a data set is stored, it will be active when that data set is recalled.

5.10.2 Working with TCG

In TCG mode the instrument uses the recorded reference points to calculate an amount of gain correction required to display each echo from same-size reflectors at the same amplitude (Figure 55 below). The recorded reference point data is stored until replaced or edited. To use the stored reference points and operate in TCG mode:

1. With the DAC/TCG Menu accessed, select the SETUP Submenu.
2. Press  next to the TCG/DAC MODE function until TCG appears ( will appear)
3. Press  next to the TCG DISPLAY function to turn this feature ON or OFF.

Note: The TCG curve begins at the first reference point recorded. It then proceeds horizontally from this amplitude of this first reference point to the depth (time position) of the last reference point recorded.

Note: When rectification is set to RF, reference lines are not displayed.

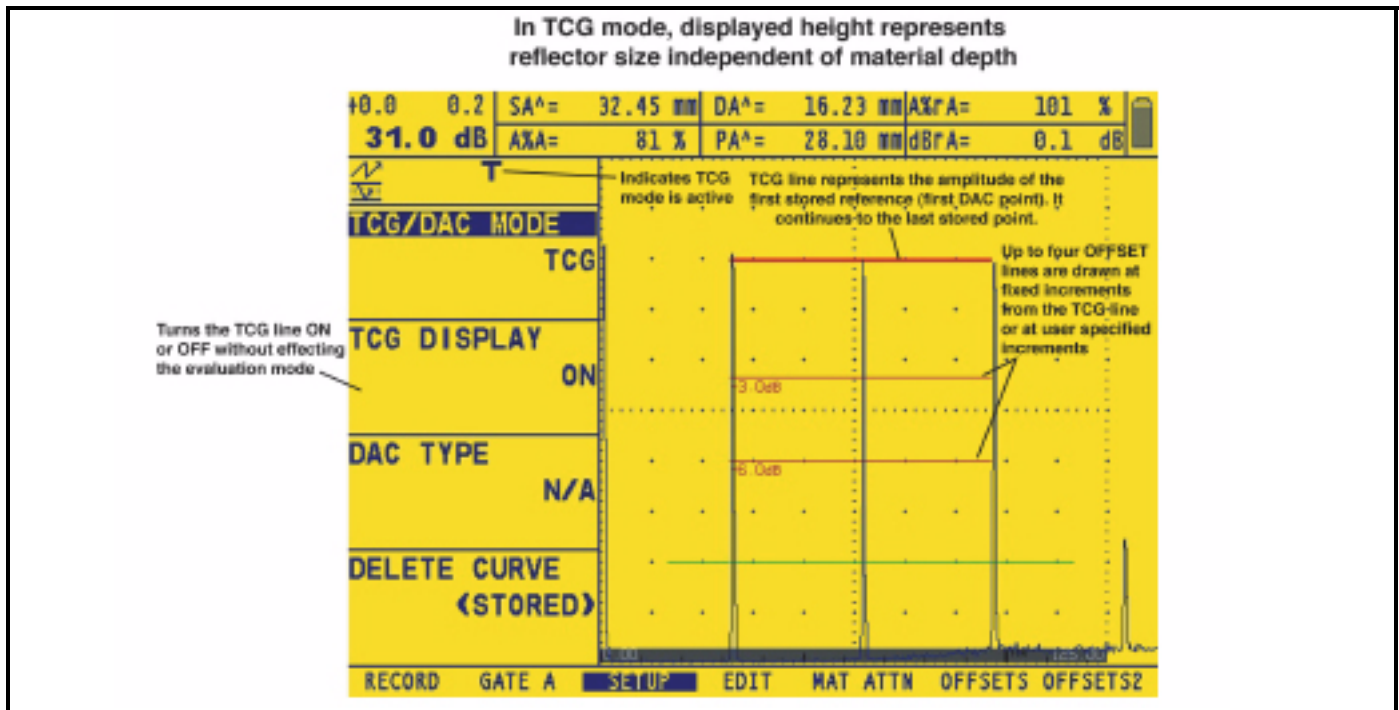

Figure 55: TCG Curve

5.11 Adjusting DAC or TCG Display and Adding Offsets

Once the DAC or TCG curves are displayed, the addition of guidelines offset from the reference line by a fixed or variable dB value, provides enhanced evaluating abilities. Similarly, the TRANSFER CORR function applies dB compensation for the difference in coupling conditions between the known standard and the test piece.

Defining DAC or TCG Curve Offsets (DAC/TCG-OFFSETS-MODE)

To add a series of guidelines, offset from the DAC or TCG curve by a definable dB increment (but not to exceed + or – 24 dB from the reference curve):

1. Access the OFFSETS Submenu (located in the DAC/TCG Menu).
2. Set the MODE function to FIXED (for evenly spaced offset lines) or CUSTOM for user-controlled offset line placement. Set this function to OFF to remove offset lines from the display.
3. If FIXED offset MODE is selected, set the OFFSET function to the dB increment at which offset lines are drawn above and below the DAC or TCG line (in Figure 5-8, a 3 dB fixed offset is specified).
4. If CUSTOM offset MODE is selected, access the OFFSETS2 Submenu and input the positive or negative offset at which each of up to four guidelines are drawn.

Setting Transfer Correction (DAC/TCG-MAT ATTN-TRANSFER CORR)







To adjust the dB compensation for differences in ultrasonic coupling between the standard and test piece:

1. Access the MAT ATTN Submenu (located in the DAC/TCG Menu).
2. Adjust the TRANSFER CORR function as required to compensate for coupling differences.

Note: While TRANSFER CORR is set to any value other than 0, the displayed gain value will appear in a contrasting color, indicating that the amount of applied gain differs from the listed “instrument” gain (the contrasting color does not appear when the display color is set to the high-contrast BLACK on WHITE).



5.12 Editing and Deleting DAC and TCG Reference Points

After reference points are recorded, they may be individually deleted, their values may be manually adjusted, or new points may be manually input (as long as the total number does not exceed 15 points). To edit points or input additional points:

1. With the DAC/TCG Menu accessed, select the EDIT submenu.
2. Press  next to the POINT function until the desired point number (or NEW if adding a new point) appears.
3. Press  next to the POINT POS. function to adjust (input for NEW points) the point’s horizontal position.
4. Press  next to the POINT GAIN function to adjust (input for NEW points) the point’s applied gain (vertical position). Note that this adjustment applies regardless of whether the point is used for TCG reference or a DAC Curve.
5. Press  next to the ENTER function to input the adjusted point values (or new point’s position). The DAC Curve or TCG reference function will be adjusted to match this edited input.
6. To delete any single DAC point, press and hold  next to the POINT, POINT POS, or POINT GAIN functions while the point to be deleted is active. Press , when prompted, to confirm the deletion. Note that the first point can not be deleted and that all DAC curves must contain at least two points. Therefore, if a curve has only two points stored, neither can be deleted. (see Section 5.13 to delete an entire set of DAC points).

5.13 Deleting a DAC Curve or TCG Reference Points

To delete a stored DAC curve or TCG reference points:

1. With the DAC/TCG Menu activated, select the SETUP submenu.
2. Press  next to the DELETE CURVE function (see [Figure 53](#) on page 118).
3. Press  next to the DELETE CURVE function a second time. Then press  to confirm your selection.
4. The statement in the function box will change to TCG/DAC MODE OFF.

5.14 DGS Evaluation Mode

Note: Result-evaluating features, such as DGS, are first selected by the user via the EVAL MODE function (located in the EVAL Menu). The selected evaluation feature's menu then appears in the HOME Menu.

The instrument's Distance Gain Sizing (DGS) feature is accessed through the DGS menu, which is located on the HOME menu bar. The DGS feature allows the user to use a particular probe to compare a reflector in a test piece with a known standard reflector.

The DGS feature relies on a reference curve based on a recorded reference point. The procedure for recording a reference point using the DGS Menu is described below.

Using the DGS feature (Distance Gain Size), you can compare the reflecting power of a natural flaw in the test object with that of a theoretical flaw (circular disk-shaped equivalent reflector) at the same depth.

Attention:

You are comparing the reflecting power of a natural flaw with that of a theoretical flaw. No definite conclusions may be drawn on the natural flaw (roughness, inclined position, etc.).

The so-called DGS diagram forms the basis for this comparison of the reflecting power. This diagram consists of a set of curves showing the connection of three influencing variables:

- Distance **D** between the probe and circular disk-shaped equivalent reflector
- Difference in gain **G** between various large circular disk-shaped equivalent reflectors and an infinitely large backwall
- Size **S** of the circular disk-shaped equivalent reflector. The influencing variable S always remains constant for one curve of the set of curves

The advantage of the DGS method lies in the fact that you can carry out reproducible evaluations of small discontinuities. The reproducibility is most of all important, for example, whenever you aim to carry out an acceptance test.

5.14 DGS Evaluation Mode (cont.)

Apart from the influencing variables already mentioned, there are other factors determining the curve shape:

- sound attenuation
- transfer losses
- amplitude correction value
- probe

The following probe parameters affect the curve shape:

- element or crystal diameter
- delay length
- delay velocity

You can adjust these parameters on the instrument in such a way that you can use the DGS method with many different probes and on different materials. When the DGS function is in use, echoes from equally sized reflectors located at varying depths appear to lie along the DGS Reference Curve. When operating in DGS mode, the DGS Reference Curve appears on the display screen. Before using the DGS function, do the following:

- Calibrate the instrument/probe combination
- Make all required instrument settings related to the pulser, receiver, and material-velocity settings.

The instrument will prevent changes to certain settings after the DGS Reference Echo has been recorded and DGS is turned ON.

5.14.1 Specifying a Probe and Preparing to Record the Reference Echo

Before using the DGS feature to evaluate reflectors in test pieces, the characteristics of the attached probe must be specified, certain characteristics of the reference standard must be input, and a reference echo must be stored. To specify the probe characteristics:

1. Press  below the DGS Menu on the HOME menu bar.
2. Select the SETUP Submenu, then the PROBE # function. Once activated, this function allows you to choose from the list of probe types in Table 2 on page 126. These are probes for which probe characteristics are already input in the instrument, with the exception of the user-defined probe (PROBE # 0):
3. If the user-defined probe type (PROBE #0) is selected, you can then select the PROBE NAME function. Then use the Gain and Function knobs (the Gain knob changes location within the name, the Function knob changes the character value) to input a new name. Note that selecting any PROBE # value other than 0 will prevent you from modifying the PROBE NAME or any of the other settings described in Step 4.
4. If the user-defined probe type (PROBE #0) is selected, you must then select the DGS PROBE submenu.

XTAL FREQUENCY—The probe's frequency rating

EFF. DIAMETER—The probe element's effective diameter rating

DELAY VELOCITY—User determined delay-line velocity

Note that these characteristics can't be changed for any probes other than PROBE #0.

5.14.1 Specifying a Probe and Preparing to Record the Reference Echo (cont.)

Table 2: DGS Probe Number Assignments

Instrument Setting	Probe Type	Instrument Setting	Probe Type
PROBE #0	User-defined	PROBE #20	WB60-1
PROBE #1	B1S	PROBE #21	WB70-1
PROBE #2	B2S	PROBE #22	WB45-2
PROBE #3	B4S	PROBE #23	WB60-2
PROBE #4	MB2S	PROBE #24	WB70-2
PROBE #5	MB4S	PROBE #25	MSEB-2
PROBE #6	MB5S	PROBE #26	MSEB-4
PROBE #7	MWB45-2	PROBE #27	MSEB-4 (roof angle)
PROBE #8	MWB60-2	PROBE #28	MSEB-5
PROBE #9	MWB70-2	PROBE #29	SEB-1
PROBE #10	MWB45-4	PROBE #30	SEB-2 KF5
PROBE #11	MWB60-4	PROBE #31	SEB-4 KF8
PROBE #12	MWB70-4	PROBE #32	SEB-2
PROBE #13	SWB45-2	PROBE #33	SEB-4
PROBE #14	SWB60-2	PROBE #34	MWB45-2 ^{tD} (45° 2 MHz) ¹
PROBE #15	SWB70-2	PROBE #35	MWB60-2 ^{tD} (60° 2 MHz) ¹
PROBE #16	SWB45-5	PROBE #36	MWB70-2 ^{tD} (70° 2 MHz) ¹
PROBE #17	SWB60-5	PROBE #37	MWB45-4 ^{tD} (45° 4 MHz) ¹
PROBE #18	SWB70-6	PROBE #38	MWB60-4 ^{tD} (60° 4MHz) ¹
PROBE #19	WB45-1	PROBE #39	MWB70-4 ^{tD} (70° 4 MHz) ¹

¹ On these probes, the user interface limits the material velocity to 3,255 km/s ± 5%.

5.14.2 Record the Reference Echo that Defines the DGS Curve

Prior to generating the DGS curve, a test standard with a known reflector must be used to define a reference point. Acceptable test standards include these reference types:

- BW—Backwall echo with reference defect size defined as infinity
- SDH—Side Drilled Hole with a reference defect size defined as the hole's diameter
- FBH—Flat Bottom Hole with a reference defect size equal to the hole's facial diameter

Follow these steps and Figure 56 on the next page to record a reference echo.

5.14.2 Record the Reference Echo that Defines the DGS Curve (cont.)

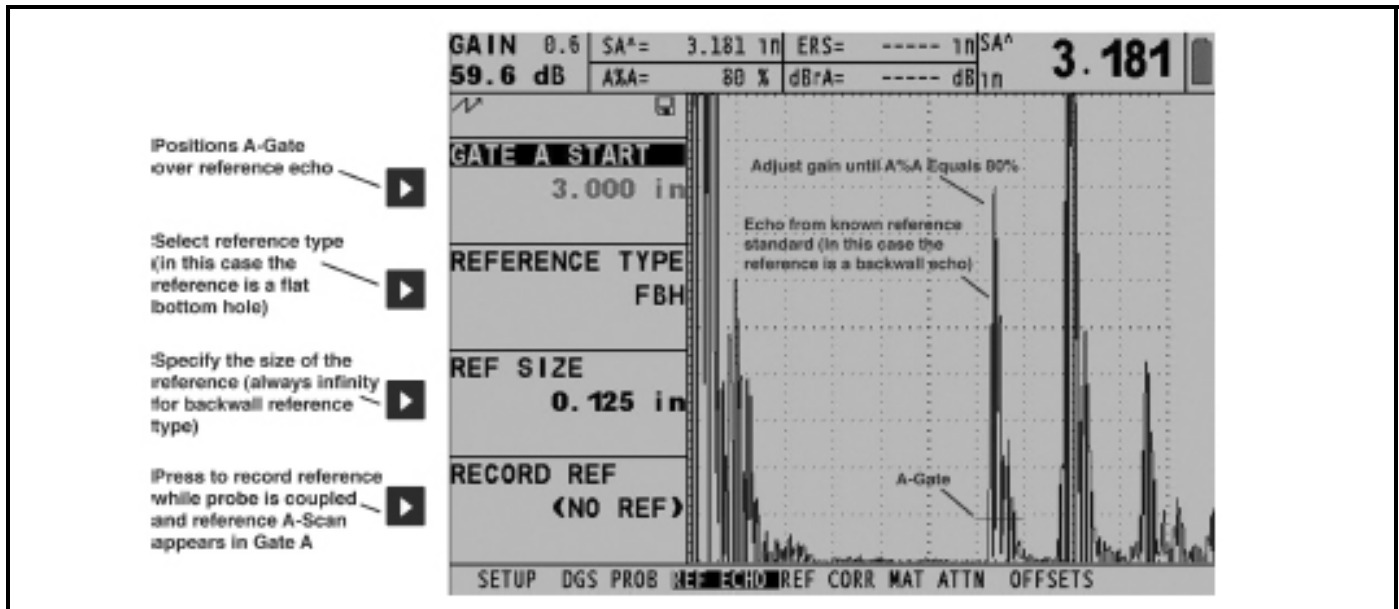





Figure 56: Recording a DGS reference point from which a DGS Curve will be generated.

1. Select the REF ECHO submenu, then the REFERENCE TYPE function. Once activated, this function allows you to select one of the three reference types described above, and specify the size of the known standard's reference flaw.
2. Couple the probe to the known standard, capture the reference flaw so that it's reflected echo is displayed on the instrument's A-Scan, and adjust the A-Gate's starting point to ensure that the resulting echo triggers the gate.
3. Adjust the gain knob until the reference flaw's A-Scan peak measures 80% of FSH ($A\%A = 80\%$).
4. With the probe coupled to the standard, and the reference flaw's echo captured by the A-Gate, press  next to the RECORD REF function to store a DGS reference echo.

Note: The AUTO 80 function allows for automatic application of gain to set A-Gate's triggering echo to 80% of full screen height. This function can be accessed at any time via the knob emulator menu (activated by pressing ).

Note: When a DGS reference echo is stored, the  will appear in the display's status bar (upper left corner). Only one DGS reference echo can be stored at a time. To delete the currently stored reference, access the REF CORR submenu, select DELETE REF, and follow the on-screen prompts.

Note: When a DGS reference echo is stored, two measurement result boxes will be automatically set (if not already configured) to display SA and A%A values.

These two adjustments should be made prior to recording a reference echo. Changing these values after the DGS curve is generated will cause the curve to be deleted.

REF ATTN (found in the REF CORR submenu)— Specify a sound attenuation value (in dB per inch or mm of material thickness) for the material from which the known standard is made.

AMPL CORRECT (found in the REF CORR submenu)— Correction required when using an angle-beam type probe. This value is specified on the probe's data sheet.

5.14.3 Display and Adjust the DGS Curve

Once a reference echo has been recorded, the DGS curve is displayed simply by selecting the SETUP submenu in the DGS menu, then setting the DGS MODE function to ON (Figure 57 below). Note that switching this value to OFF does not delete the curve — it simply removes the curve from the display and disables the DGS mode. Once the DGS Curve is displayed, it can be adjusted using one of these three functions:

TEST ATTN (found in the MAT ATTN submenu)— Specify a sound attenuation value (in dB per inch or mm of material thickness) for the material from which the test piece is made.

TRANSFER CORR. (found in the MAT ATTN Submenu) —dB compensation for difference in coupling conditions between the known standard and the test piece. Setting this to values other than zero will cause a “T” to be added to the DGS Icon and the displayed gain value to appear in a contrasting color, indicating that the amount of applied gain differs from the listed “instrument” gain (the contrasting color does not appear when the display color is set to the high-contrast BLACK on WHITE).

DGS CURVE (found in the SETUP submenu)—Positions the probe’s DGS Curve based on the size of the reflector (flaw) being tested. The setting will usually depend on the largest acceptable flaw size.

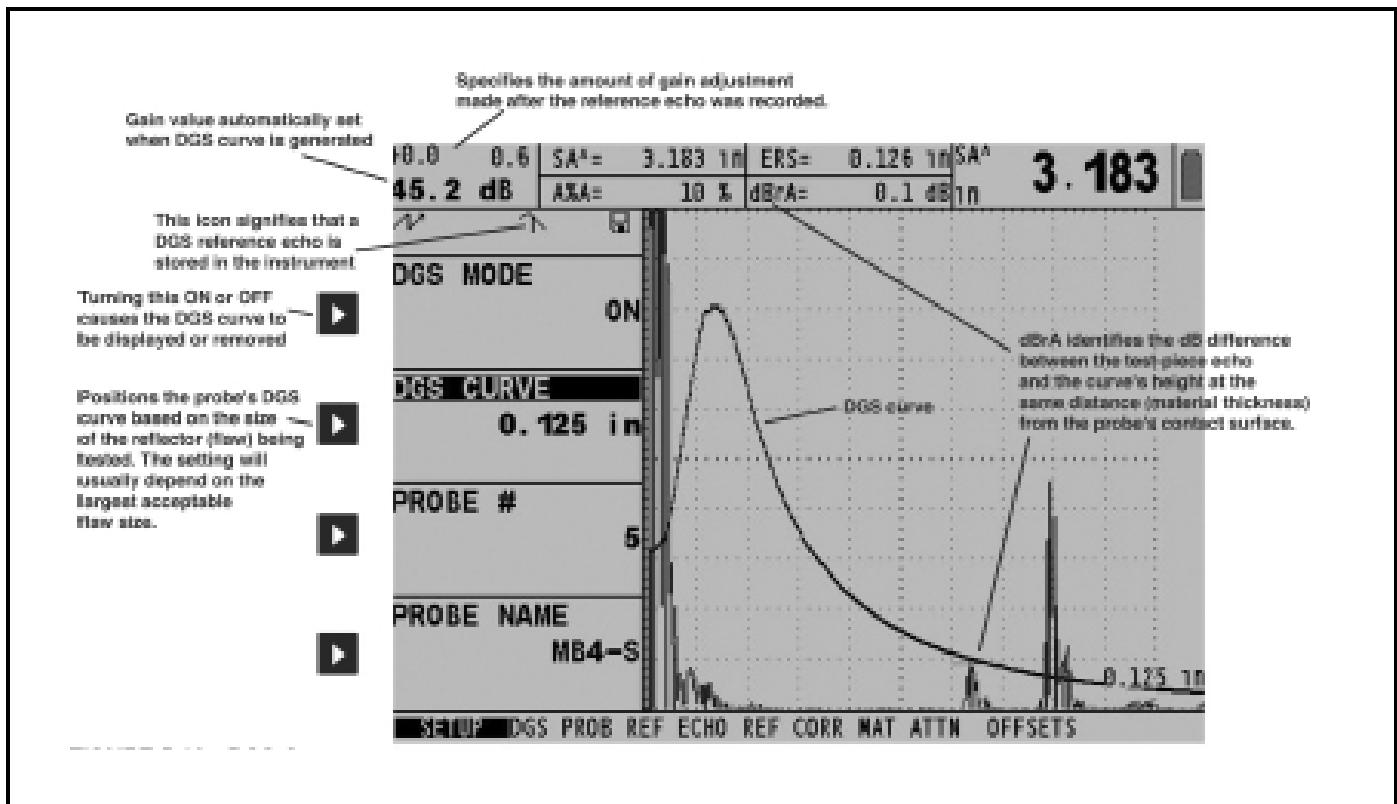

Figure 57: DGS Curve

5.14.4 Evaluating Results in DGS Mode

Once the DGS curve is recorded and displayed (by turning DGS MODE on), echoes are automatically compared to the recorded reference. There are three ways this comparison can be made and two additional DGS related results that can be displayed:

A%rA—Amplitude of the signal crossing the A-Gate as a percentage of the corresponding DGS curve amplitude.

dBrA—dB equivalent height difference between the signal crossing A-Gate and the corresponding DGS curve height. This value is shown in Figure 57 on the previous page.

ERS—Evaluates the reflected echo and calculates the Equivalent Reflector Size

Gt—DGS test gain, which initializes the DGS curve's max height at 80% FSH.

Gr—DGS reference gain, which represents the instrument gain at which the reference echo's peak reaches 80% FSH.

To aid in interpreting the DGS Mode's display, the instrument will display up to four curves representing fixed-gain offsets from the DGS curve. These curves are enabled and positioned (by specifying the dB-equivalent amount they are offset above or below the DGS curve) by accessing the OFFSETS submenu in the DGS menu.

5.14.5 Locks, Error Messages

As long as a valid reference echo is stored, no functions can be changed which could cause an incorrect DGS evaluation. If an attempt is made to change such a function, the following error message will appear:

“Function Locked—DGS Reference has been recorded”

The DGS evaluation must likewise be switched off and the reference echo deleted in the case of selecting a new probe, e.g., for a new test application.

5.14.6 Validity of the DGS Method





Echo amplitude evaluations according to the DGS method are only reliable and reproducible in cases when:

- The reference echo is received from the test object if possible. If this is not possible, it should be ensured that the reference block is made of the same material as the test object.
- The evaluation is carried out using the same probe which was also used for recording the reference echo. Another probe of the same type can be used after recording a new reference echo.
- Echo amplitudes for reflector distances smaller than half of the probe's near-field length are subject to heavy variation – for physical reasons due to interference phenomena effecting the area. Thus evaluation results may fluctuate more than the usually permissible +2 dB. An evaluation according to the DGS method is possible but not recommended for this case.

5.15 dB REF Evaluation Mode

Note: Result-evaluating features, such as dB REF, are first selected by the user via the EVAL MODE function (located in the EVAL Menu). The selected evaluation feature's menu then appears in the HOME Menu.

When dB REF is activated, the amplitude of the highest echo in A-Gate becomes the reference echo against which subsequent echo amplitudes are evaluated. At the time of dB REF activation, the gain setting also becomes a reference against which subsequent gain values are compared.

1. Access the SETUP Submenu (located in the dB REF Menu).
2. Locate the reference echo in A-Gate and adjust gain as required. Press  (two times) next to the RECORD function to record the reference echo. The function box will now indicate that a reference is stored (Figure 58 on the next page). Also note the following:
 - The instrument gain and the reference echo's amplitude now appear in the function box titled REFERENCE.
 - The instrument automatically switches the dB REF MODE function to ON and the  appears on the display.
 - Setting MODE to OFF allows you to disable the dB REF feature without deleting the reference echo.
 - Pressing  next to DELETE REF, then confirming by pressing , deletes the current reference.

It's important to remember that the highest echo in A-Gate and GAIN setting, when dB REF is selected, will become the reference amplitude and gain value for as long as dB REF is activated.

Note: The reference echo amplitude must not exceed 100% of full-screen height.

Once dB REF is activated, the Gain-Display Window lists both the Reference Gain and Incremental Gain levels.

Also, the icon will appear. The Reference Gain remains constant throughout the dB REF session while the Incremental Gain value changes as the Gain Knob is rotated (Figure 58 on the next page).

After dB REF is activated, any amplitude measurements are stated in relation to the reference echo amplitude. Available amplitude readings (see Section 5.3 to change display-box reading values) when operating in dB REF mode are

- dBrA—dB difference between the reference echo and the highest echo to cross A-Gate.
- A%rA—Amplitude of the signal crossing the A-Gate as a percentage of the reference amplitude.
- dBrB—dB difference between the reference echo and the highest echo to cross B-Gate.
- A%rB—Amplitude of the signal crossing the B-Gate as a percentage of the reference amplitude.

5.15 dB REF Evaluation Mode (cont.)

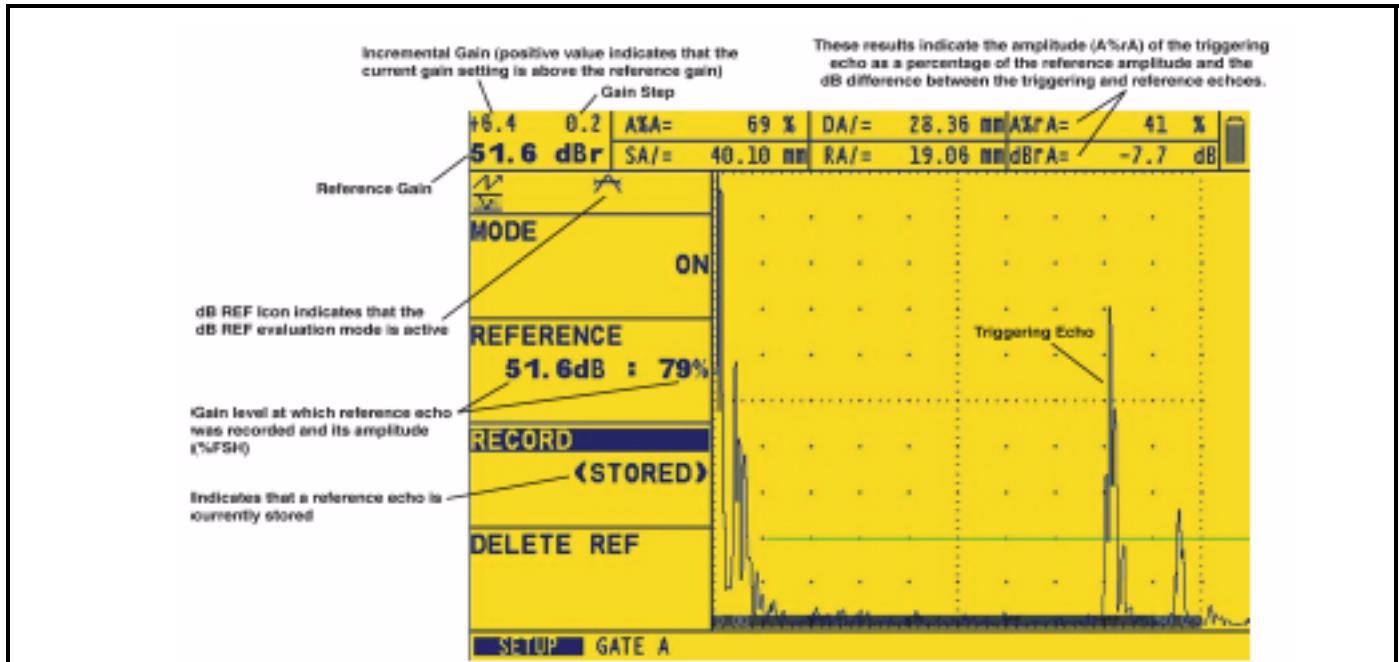

Figure 58: dB Ref capabilities

5.16 AWS D1.1 Weld Rating Evaluation Mode

Note: Result-evaluating features, such as AWS D1.1 / D1.5, are first selected by the user via the EVAL MODE function (located in the EVAL Menu). The selected evaluation feature's menu then appears in the HOME Menu.

This feature allows analysis of welds according to AWS specifications D1.1 or D1.5 and provides a D1.1 or D1.5 rating. The AWS D1.1 feature is accessed via the HOME Menu. The feature utilizes four AWS-specified variables including:

A INDICATION—Gain (in dB) required to position an A-Scan echo's peak (from the measured reflector) at an amplitude equal to the reference amplitude (between 10 and 90% of full screen height)

B REFERENCE—Gain (in dB) required to position an AScan echo's peak (from the reference reflector) at the user selected amplitude (between 10 and 90% of FSH)

C ATTENUATION—Determined by subtracting 1 inch from the sound-path distance to the discontinuity, using the equation (inch units): $C = (SA-1) \times 2$. This compensates for sound loss from material attenuation along the sound path to the discontinuity.

D D1.1 RATING—Calculated based on the AWS formula: $D = A-B-C$ (See NOTE).

5.16 AWS D1.1 Weld Rating Evaluation Mode (cont.)

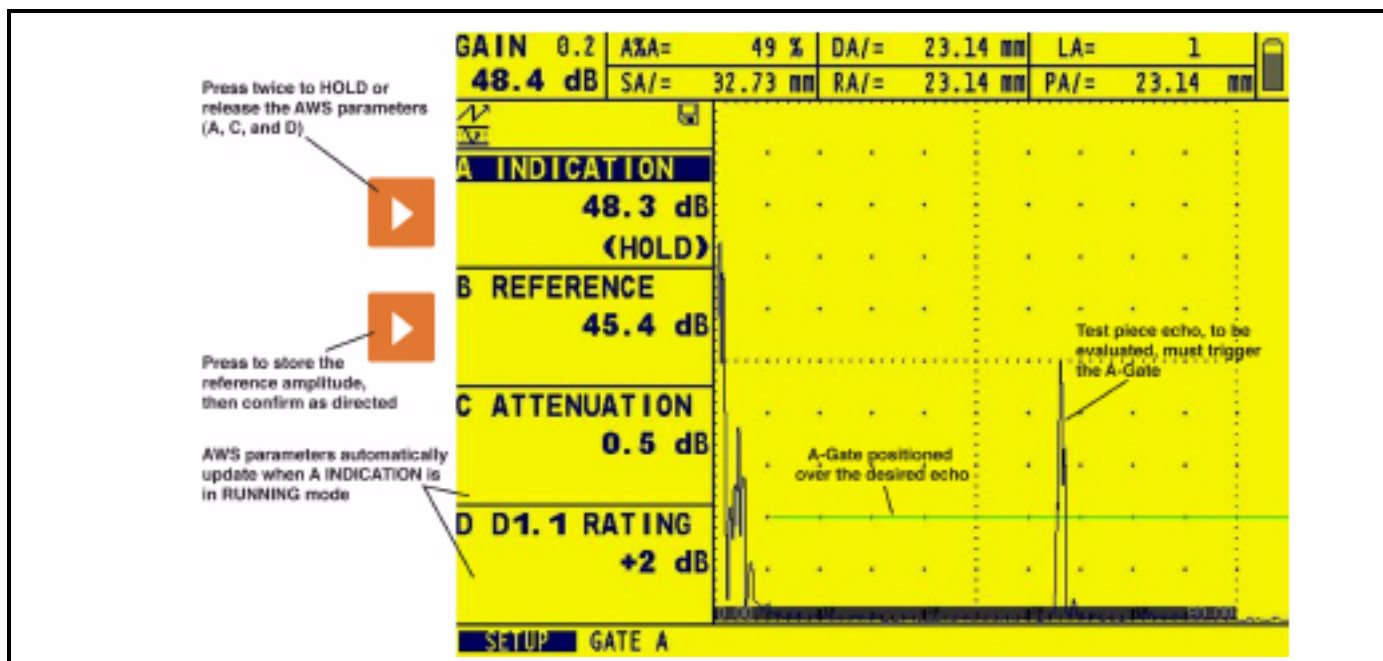





Figure 59: After adjusting the gain so that the reference echo's peak is between 20% and 90% of full screen height, record the reference dB. This reference value will be stored in the instrument until manually changed.

Note: The dB value of A-Indication will be automatically adjusted to match the amplitude of the B-Ref upon performing the dB rating calculation.

Before activating the AWS D1.1/D1.5 weld rating feature, be sure that all instrument settings are properly adjusted for the specific measurement application. Then access the AWS D1.1 Menu (via the HOME Menu) and follow this procedure:

1. Apply couplant and couple the probe to a suitable reference test standard.
2. Ensure that the A-Gate is positioned over the desired echo. Then adjust the gain until the peak of the desired reference echo reaches the desired amplitude as shown in Figure 59 on page 132. Note that if the echo's peak amplitude (A%A) does not fall between 10% and 90%, the inputted point will not be accepted.
3. Press  next to the B REFERENCE function (then  to confirm) to define the reference dB level.
4. To evaluate a reflector in a test piece, couple the probe to the test piece. Now adjust the A-Gate position, if required, so that it is over the desired echo as shown in Figure 59 on page 132.
5. Adjust the gain until the peak of the test-piece's echo reaches the desired screen height as shown in Figure 59 on page 132. The dB value that is recorded for A-Indication will be automatically adjusted based upon the amplitude difference between it and the value recorded for B-REF. It will usually NOT match the instrument's dB gain setting.
6. With the AWS D1.1 SETUP Submenu displayed, note that the A, C, and D parameters automatically update to match the A-Gate triggering echo. Press  (two times) next to A INDICATION to HOLD the current parameters until pressed again. Note that the displayed RESULTS continue to update while the A, C, and D parameters are held (press  to freeze the display and results).

5.17 JISDAC Evaluation Mode

Note: *Result-evaluating features, such as JISDAC, are first selected by the user via the EVAL MODE function (located in the EVAL Menu). The selected evaluation feature's menu then appears in the HOME Menu. While operating in JISDAC mode, the A-Gate TOF MODE must be set to PEAK or JFLANK (see Section 5.1.2).*

Conventional measurements can be made using the JIS Distance Amplitude Correction (JISDAC) function (Figure 60 on page 134). The function operates based on a set of user-recorded data points. These points are recorded from the JIS/DAC menu as described below.

The JISDAC function displays all echoes at their true amplitude. However, when operating in JISDAC mode, a Distance Amplitude Correction curve is superimposed on the A-Scan display. The curve, like the one shown in Figure 60 on page 134, represents constant reflector size at varying material depth.

When displayed, the JISDAC curve visually represents a line of constant reflector peaks over a range of material depths. Remember that in JISDAC mode, the only deviation from traditional display and operation is the appearance of the JISDAC curve and a series of OFFSET curves. All A-Scan echoes are displayed at their non-compensated height. A JISDAC curve can be based on up to 15 data points (material depths).

A JISDAC curve is programmed using a series of same-reflector echoes at various depths covering the range of depths to be inspected in the test material. Because near field and beam spread vary according to transducer size and frequency, and materials vary in attenuation and velocity, JISDAC must be programmed differently for different applications.

The dynamic range of the JISDAC function is 60 dB. Maximum curve slope is 12 dB per microsecond. Successive data points do not have to decrease in amplitude. That is, the JISDAC curve does not have to have a constantly descending slope.

5.17.1 Recording the JISDAC Curve

JISDAC Curve points are typically taken from a standard with equally sized reflectors (holes) located at various material depths. The primary echo from each of these points (for up to a total of 15 echoes) are recorded. When JISDAC is active, the instrument displays a line that represents echo peaks for constant reflectors at varying material depth. This line is drawn as either a curved (linear in gain) line based on a series of collected JISDAC points or a series of straight line segments that join these JISDAC points. Only one JISDAC curve can be stored at a time. To program the JISDAC Curve:

1. Access the JISDAC menu by pressing  below it. The RECORD Submenu will be selected (Figure 60 on page 134).
2. Couple the probe to the first reference point and adjust the A-Gate so that it is broken by the primary echo. If necessary, use the Gain Knob to adjust the gain so that the echo crosses the A-Gate and the highest peak in gate A is at approximately 80% of full-screen height. The highest peak must not be higher than 100% full-screen height.

Note: *The AUTO 80 function allows for automatic application of gain to set A-Gate's triggering echo to 80% of full screen height. Press  to select AUTO 80 (located in the RECORD Submenu), then press and hold it again.*

This function can also be accessed at any time via the knob emulator menu (activated by pressing .

3. While the Gate is lined up over the first reference echo, press  next to the RECORD function. When the value of the RECORD function changes from 0 to 1, you have recorded the first JISDAC Curve point. Note that the first JISDAC point is treated as the reference echo. The amplitude value at which this point is recorded becomes the "reference amplitude" value.

5.17.1 Recording the JISDAC Curve (cont.)

Note: When the first JISDAC reference point is stored, two measurement result boxes will be automatically set (if not already configured) to display SA and A%A values.

4. Continue to record additional Curve points, following steps 2 and 3, up to a maximum of 15 points (note that at least two JISDAC Curve points are required).
5. When complete, press  next to FINISH.

5.17.2 Working with DAC

In JISDAC mode the instrument uses the user-input reference points to create a curve representing the amplitudes of echoes representing same-size reflectors at varying material depth (Figure 60 below). To turn JISDAC evaluation mode ON or OFF:

1. With the JISDAC Menu accessed, select the SETUP submenu.
2. Press  next to the JISDAC function to select ON or OFF. The JISDAC Curve will appear whenever turned ON.

Interpreting JISDAC Lines and Classes

The JISDAC display contains a recorded reference line and five fixed offset lines. Three of the lines are labeled as follows:

- H Line – Connects the recorded reference points
- M Line – Fixed offset positioned 6 dB below the H line
- L Line – Fixed offset positioned 12 dB below the H line

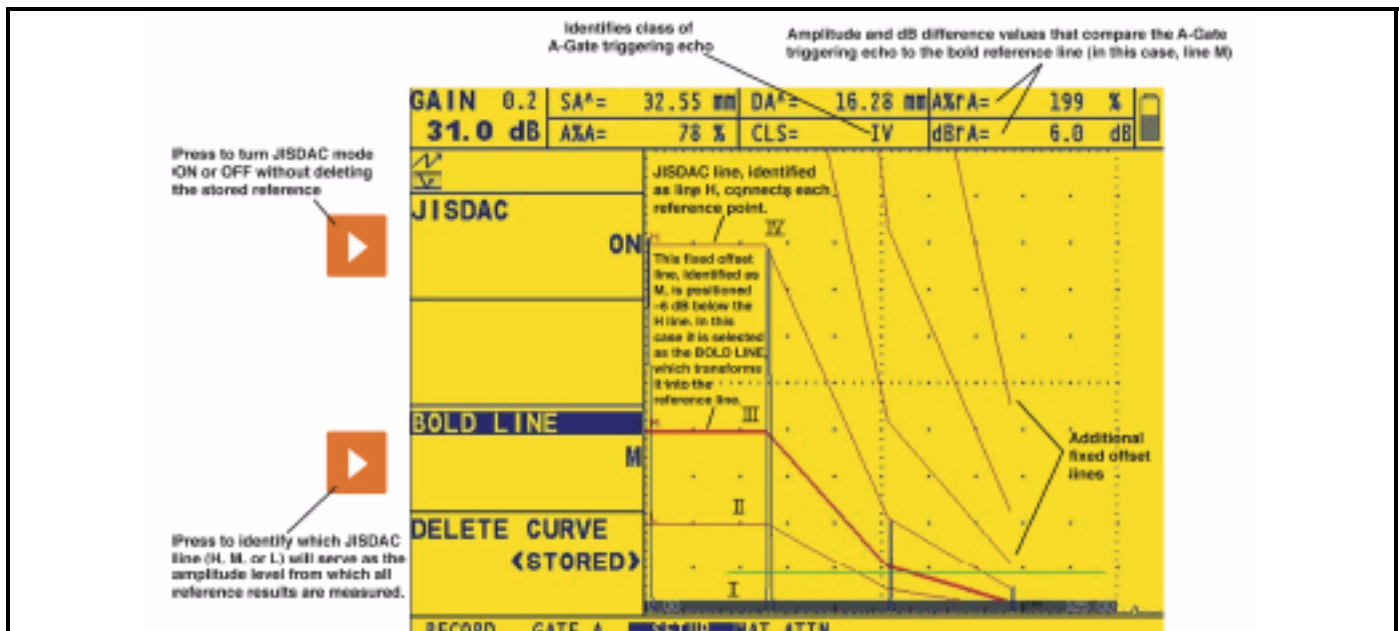



Figure 60: Storing at least two JISDAC points allows you to generate a recorded reference line (identified as H) and corresponding offset lines. Line H, M, or L can be chosen as the reference line from which measurements are based.

Any one of these three lines can be identified as the reference from which measurements are based (see the **BOLD LINE** function below). In addition, the remaining three offset lines are drawn at 6, 12, and 18 dB above the H line.

The regions of the A-Scan display bordered by the H, M, and L lines are identified with JIS Class numbers. These identifying numbers, shown in Figure 60 as Roman numerals, can also be displayed as results (see the CLS result in Figure 60). CLS reports the region that contains the peak of the A-Gate triggering echo.

Defining a BOLD LINE Measurement Reference (JISDAC-SETUP-BOLD LINE)

The user-defined measurement reference is selected as follows:

1. Access the SETUP Submenu (located in the JISDAC Menu).
2. Press  next to the BOLD LINE function to select the H, M, or L line.

Note: The selected line is now shown in bold on the A-Scan display. This line now serves as the reference level from which all reference measurements (such as A%rA or dBrB) are made.

Setting TRANSFER CORREction (JISDAC-MAT ATTN-TRANSFER CORR)



The TRANSFER CORR function applies dB compensation for the difference in coupling conditions between the known standard and the test piece.

1. Access the MAT ATTN Submenu (located in the JISDAC Menu).
2. Adjust the TRANSFER CORR function as required to compensate for coupling differences.

Note: While TRANSFER CORR is set to any value other than 0, the displayed gain value will appear in a contrasting color, indicating that the amount of applied gain differs from the listed “instrument” gain (the contrasting color does not appear when the display color is set to the high-contrast BLACK on WHITE).

5.17.3 Deleting a JISDAC Curve

To delete a stored JISDAC curve

1. With the JISDAC Menu activated, select the SETUP Submenu.
2. Press  next to the DELETE CURVE function (see Figure 53 on page 118).
3. Press  next to the DELETE CURVE function a second time. Then press  to confirm your selection.
4. The statement in the JISDAC function box will change to OFF.

[no content intended for this page - proceed to next page]

Chapter 6. Storing Data Sets and Generating Reports

Instrument settings can be stored as data sets. Most functional settings are saved within a data set. When a stored data set is later recalled, all active function settings will be modified to match those contained in the data set. The FILES Menu is used to create, recall, and delete data sets.

In this chapter, you'll learn how to work with all FILES Menu functions, including:

- CREATE and name new data set files (Section 6.1)
- SAVE EDITS to existing data sets (Section 6.1)
- RECALL existing data sets (Section 6.2)
- Delete (CLEAR) existing data sets (Section 6.3)
- Create and attach a MEMO to a data set (Section 6.4)
- Input REPORT-HEADER information (Section 6.5)
- Specify REPORT contents and generate reports (Section 6.6)

6.1 Data Set Files

Data set files are used to store a specific instrument-setup configuration. Instrument settings and the active A-Scan present when the data set file is created can be stored in the file. When the data set file is recalled, all instrument settings are modified to match the settings stored in the data set file.

*Note: Data sets stored on an SD card will include a frozen display image and related A-Scans. Data sets stored in the instrument's internal memory, will **not** include these images. When the data set is recalled, the stored (frozen) image will be displayed and its related A-Scans evaluated until the display is unfrozen.*

Note: Phased Array and conventional files are differentiated by their extensions (.pop and .cop respectively).

Once a data set file is opened, instrument settings may be modified from their data-set-file configurations. **However, these changes will only affect the data set if additional actions are taken to do so as described in “Editing Active Files” on page 139. Otherwise, the original file structure will remain as-saved.**

6.1 Data Set Files (cont.)

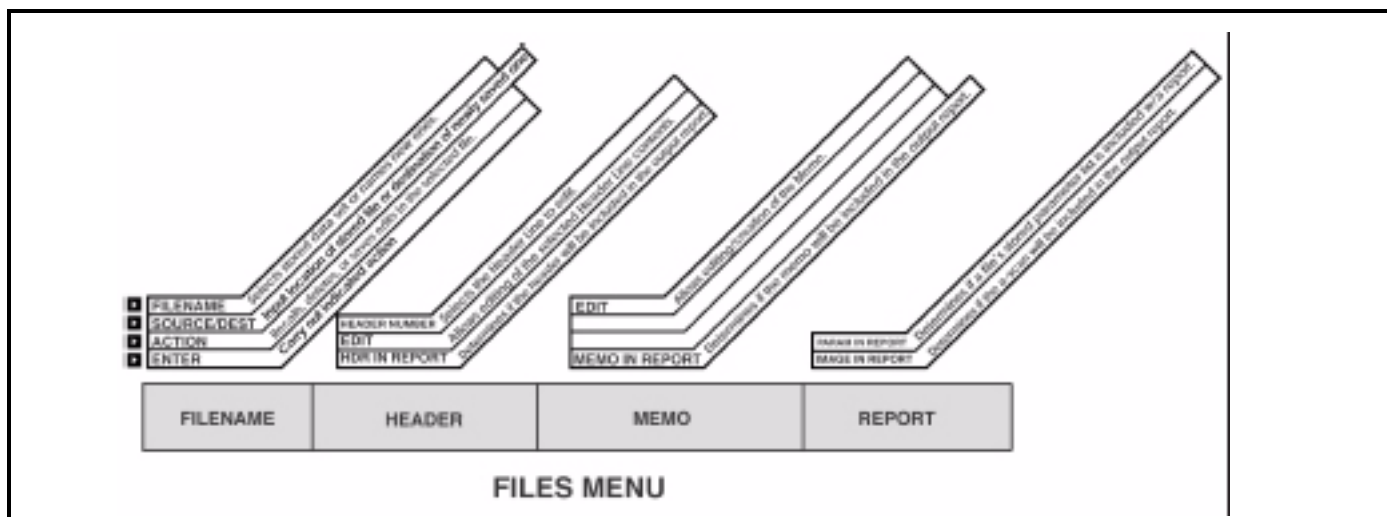







Figure 61: The Files Menu allows access to all data set and output functions.

6.1.1 Creating Data Set Files

To store instrument settings in a new data-set file, follow this procedure

1. Activate the FILES MENU.
2. Press  next to ACTION until STORE DATASET appears.
3. Press  twice next to FILENAME. Use the two knobs and the instrument's text-entry feature to input the data set's name (as shown in Figure 62 on page 139). Note that an “underscore” character is not available and can therefore *not* be included in data set file names.

Note: Press and hold  for three seconds to clear filename. Press  one more time to get the edit cursor.

4. Press  next to SOURCE/DEST until the desired file-saving destination appears. Choices include:
 - INT MEMORY* – A limited number of data sets can be stored in the instrument; however, these data sets will *not* include a stored image or related A-Scans.
 - SD CARD* – Primary destination for data sets, which will include a frozen display image and related A-Scans.
 - DIALOG PROBE (Phased Array only)* – Abbreviated data sets can be stored in connected phased-array dialog probes.
5. With the desired data set name input, press  next to ENTER to complete the data set creation process. The instrument's settings have been saved in the data set.

6.1.1 Creating Data Set Files (cont.)

Note: Pressing and holding  for three seconds causes a dataset to be stored or a report to be generated based on the ACTION specified in the FILENAME Submenu (in phased array mode). In conventional mode, this three-second press always results in a report being stored. The stored dataset will be assigned the name entered in the FILENAME function. This default name will increment by 1 the next time a new dataset is created (i.e., after the dataset name “TANKAF” is entered, the next dataset name will be automatically named

“TANKAF1”) when  is pressed and held unless another name is entered. This “auto-appending” naming feature also applies to reports.

6.1.2 Editing Active Files

Parameter settings stored in an existing data set can be edited anytime the file is active. To save these edits to any active file, do the following:

1. Recall the dataset and make all edits desired
2. Set the ACTION function (in the FILENAME submenu) to STORE DATASET.
3. Press  next to ENTER, then follow the on-screen instructions to make the edits to this file permanent.

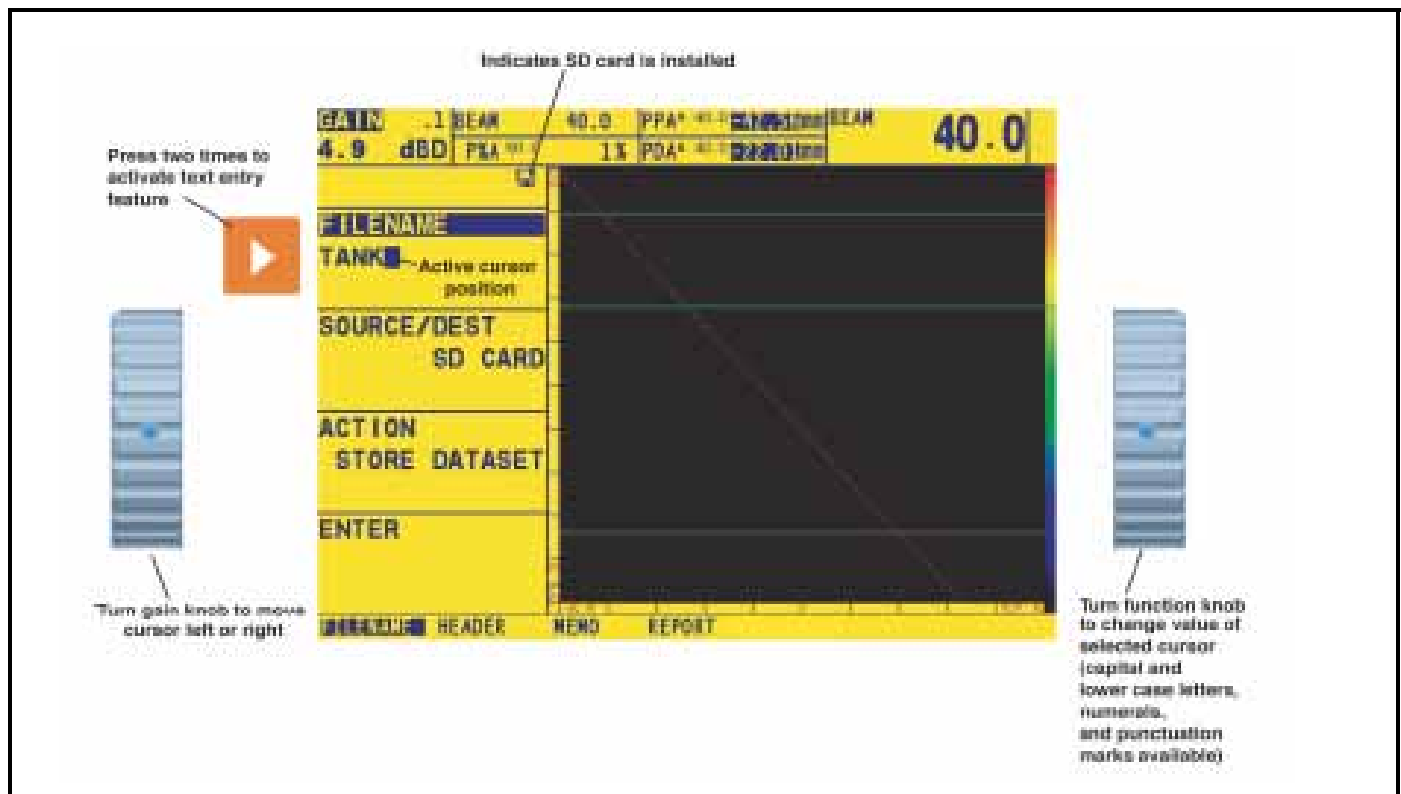





Figure 62: The Text-Entry display allows quick entering or editing of file names and other alphanumeric labels.

6.2 Recalling Existing Data Sets

Accessing an existing data-set file resets the current instrument setting to the stored data-set-file settings.







To access an existing file:

1. Activate the FILENAME submenu (in the FILES menu).
2. Press  next to SOURCE/DEST until the location of the desired data set appears.
3. Press  next to ACTION until RECALL DATASET appears.
4. Press  next to FILENAME. Turn the function knob to list the data set's stored in the designated location.
5. With the desired data set name visible, press  next to ENTER to complete the data set recall process. The instrument's settings have been modified to match those specified by the recalled data set. If the data set was stored on an SD card, the frozen image will now be displayed.

*Note: Data sets stored on an SD card will include a frozen display image and related A-Scans. Data sets stored in the instrument's internal memory, will **not** include these images. When the data set is recalled, the stored (frozen) image will be displayed and its related A-Scans evaluated until the display is unfrozen.*

6.3 Deleting (CLEARING) Existing Data Sets

Existing data files are deleted using this procedure:

1. Activate the FILENAME submenu (in the FILES menu).
2. Press  next to SOURCE/DEST until the location of the desired data set appears
3. Press  next to the ACTION function five, then turn the Function Knob until DELETE DATASET appears.
4. Press  next to the FILENAME function. Press  or turn the Function Knob until the desired filename name appears.
5. Press  next to the ENTER function. Follow the display-screen prompting and press  to confirm the file-delete command.
6. The deleted data set may not be retrieved.

6.4 Creating a Memo

Memos are attached to data set files at the time the files are stored or to Reports when they are generated. After a file is stored, the attached memo may be modified. To create or edit a memo:

1. Activate the MEMO Submenu (in the FILES menu).
2. Press  to set the EDIT function to YES. This allows you to create or edit a memo.
3. Note that the top of the display screen contains a five-line memo. The first character of the memo is now highlighted. Use the two knobs and the instrument's text-entry feature to input or edit the memo's contents (as shown in Figure 62 on page 139).

Including a File's Memo as Part of a Report

You can specify whether the memo attached to the active data file is included in a report. To add or remove an active file's memo from the stored report:

1. Activate the MEMO Submenu (in the FILES menu).
2. Press  next to the MEMO IN REPORT function. Choosing a value of YES indicates that the memo should be included in part of the report. Choosing NO omits the memo from the report.

6.5 Creating a Report Header

Report Headers are attached to data set files at the time the files are stored. After a file is stored, the attached Report Header may be edited. To create or edit a Report Header:

1. Activate the HEADER Submenu (in the FILES menu).
2. Press  to access and set the EDIT function to YES. This allows you to create or edit a Header.
3. Note that the top of the display screen contains a nine-entry report header. The first character of the header is now highlighted. Use the two knobs and the instrument's text-entry feature to input or edit the header's contents (as shown in Figure 62 on page 139).

Including a Report Header In a Generated Report

You can specify whether the report header is included in a report. To add or remove an active file's report header from the outputted report:



1. Activate the HEADER Submenu (in the FILES menu).
2. Press  next to the HDR IN REPORT function to set the value to YES. This indicates the header should be included in the report. Choosing NO omits the header from the report.

6.6 Generating a Report

Any report can be generated and stored on the SD card. The contents of a report are specified by the user. Several features of the active data file can be omitted from or included in the report as described below. Prior to creating a report for output, install the SD card.

- **Report Header** (FILE / HEADER / HDR IN REPORT)
- **Memo** (FILE / MEMO / MEMO IN REPORT)
- **A-Scan** (FILE / REPORT / IMAGE IN REPORT)
- **Listing of Data-Set Stored Instrument Settings** (FILE / REPORT / PARAM IN REPORT)

With the SD card installed and the desired data set active, to store a report you must:

1. Activate the FILENAME Submenu (located in the FILES Menus) and press  to set the ACTION Function to STORE REPORT.
2. Be sure that the SOURCE/DEST Function in the active submenu is set to SD CARD.
3. Press and hold  for three seconds to generate a report. Reports can only be stored on the SD card.

Note: The newly created report name automatically becomes the default report name. This default name will increment by 1 the next time a new report is created (i.e., after the report name "TANKAF" is entered, the next default report name will be "TANKAF1.") This feature functions only when the generated report's destination is the SD CARD.

6.6 Generating a Report (cont.)

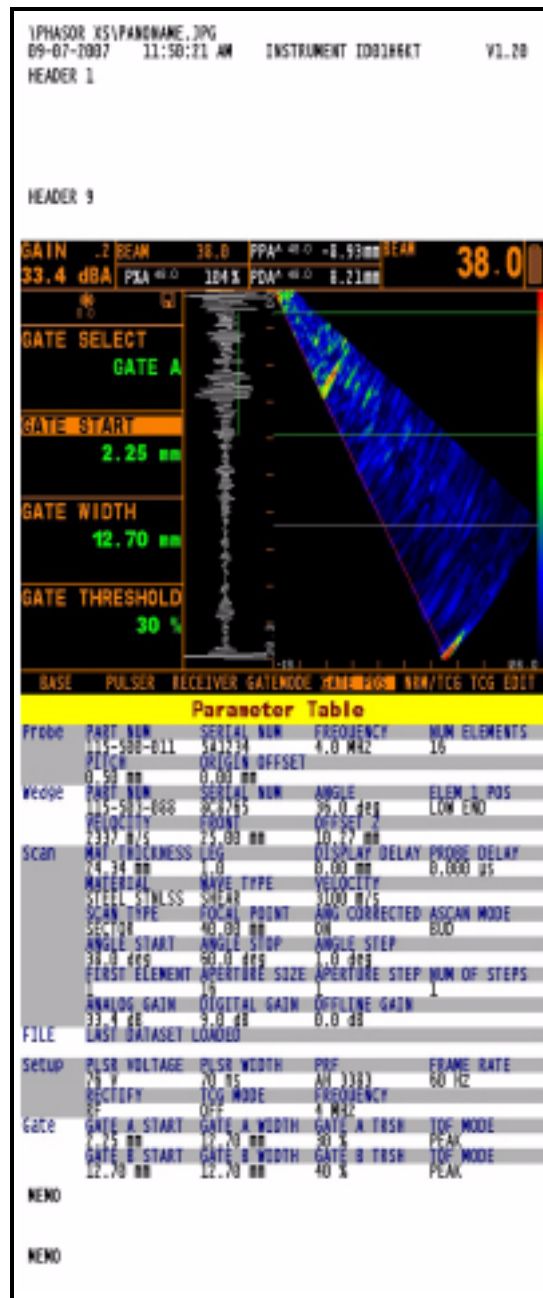

Figure 63: This phased array report includes a frozen display image.

[no content intended for this page - proceed to next page]

Chapter 7. Working in TOP View (Optional Feature)

The TOP View display option allows for scanning an area with a phased-array probe to acquire timed or positional data. The TOP View display represents the projection of reflectors from a region of interest from A- and B-Gate onto a viewable plane.

A TOP View display (initiated by setting the VIEW MODE Function in the VIEW Submenu to TOP) is generated with data collected from the A- and B-Gated region of a sector or linear scan. A frozen TOP View display provides access to buffered data for both time-of-flight (TOF) and echo amplitude. TOF and percent amplitude values are represented in the TOP View image by user-selectable color palettes. The buffered TOP View data (TOF and amplitude data from gates A and B) can be stored as part of a data set.

Note: During the scanning process, TOP View data is added to the instrument's buffer. The buffer serves only as temporary memory. To retain the data held in the buffer, it MUST be stored to a data set. Note that once the buffer is full, buffered data is automatically overwritten in TIMED CONTINUOUS mode. In TIMED mode, a full data buffer automatically stops the scanning process.

This chapter explains how to prepare for and operate in TOP View mode, which first requires that this *optional* feature be installed in your instrument. It includes instruction on how to:

- Configure the standard phased array (designated FRAME view) settings to provide the desired TOP View display (Section 7.1.1)
- Set up for TOP View during a continuous scan (see TIMED CONTINUOUS mode in Section 7.1.2)
- Set up for TOP View during an encoder-driven scan (Section 7.1.3)
- Acquire TOP View data during a continuous or encoder-driven scan (Section 7.2)
- Freeze the TOP View display and navigate through the buffered data (Section 7.3)
- Store the TOP View data in a data set (Section 7.4)
- Conduct a typical ENCODED data-acquisition session by following an application summary (Section 7.5)

Note: To avoid inadvertently deleting TOP View data before it can be stored in a data set or otherwise evaluated, refer to the various notes in Section 7.4.

7.1 Preparing for TOP View Operation

The TOP View display option allows for continuous scanning with a phased-array probe or scanning during a memory-limited session with the use of an encoder-equipped probe or in TIMED mode. The TOP View display is generated with data collected from the A- and B-gated region of a sector or linear scan.

7.1.1 Setting Up the Phased Array Prior to Displaying a TOP View

Prior to displaying a TOP View, the standard phased array views (designated as FRAME view) setup must be performed (Refer to Chapter 2). TOP View displays can be generated from either type of standard phased array scan (linear or sector). It is important to recognize that the TOP View image is based only on amplitude and TOF data recorded in Gates A and B. Further, when a data set is stored while operating in TOP View mode, amplitude and TOF data from A- and B-Gates (acquired and added to the data buffer) is stored; however, A-Scans and other results are not available.



To prepare for generating a TOP View display:

1. Be sure that the VIEW MODE Function (located in the VIEW Submenu of the DISPLAY Menu) is set to FRAME. This corresponds to standard phased array operation.
2. Set up either a linear or sector scan to match the installed probe, material type, and inspection requirements as described in Chapter 2. Calibrate the instrument/probe combination.
3. Adjust the A- and/or B-Gate starting point and width to capture the test-material region of interest (Figure 64 on page 147). Refer to Section 2.8.1 to position gates.
4. Access and adjust TOP View specific functions as described on the next page.

Note: The TOP View image is based on amplitude and TOF data recorded in Gates A and B. These gate(s) must be turned on and positioned to capture the test-material range of interest.

7.1.2 Setting Up TOP View for TIMED, or TIMED CONTINUOUS Operation

In TIMED CONT operation, the instrument continuously acquires scan data, which is added to the display's buffer. In TIMED mode, the instrument acquires data until the acquisition buffer is full. The time interval between data acquisition, which sets the TOP View display's "scrolling" speed, determines the duration of DISPLAY LENGTH. This calculated value represents the amount of scanning time represented on the TOP View display at any one time. Additional scanning data scrolls to the instrument's data buffer and is immediately viewable anytime the display is stopped (Section 7.3) or  is pressed. Refer to Figure 65 and follow these steps to configure the instrument for TOP View operation in TIMED mode. The resulting TOP View operation is shown in Figure 67 on page 151.

1. Activate the CLOCK Submenu (located in the SCAN Menu) by pressing  below it.
2. Press  to set the CLOCK Function to TIMED or TIMED CONT.
3. Press  and turn the Function Knob to set the duration (in hertz) of the SAMPLE INTRVL. The sample interval equates to the number of TOP View data lines acquired and displayed per second.
4. Note that the calculated value of DISPLAY LENGTH automatically updates. This calculated value represents the amount of scanning time represented on the TOP View display at any one time. While scanning a test piece, stopping the display (Section 7.3) allows the operator to scroll back through TOP View data that's held in the data buffer.

Note: While scanning in TIMED mode, TOP View data is first added to the display screen. When the screen is full, the initial data "scrolls" into the instrument's data buffer. Scrolling direction is defined in Step 5. In TIMED CONT Mode, when the buffer is full, acquiring new data automatically causes the oldest data in the buffer to be overwritten. At any time, the TOP View scanning process can be stopped, allowing on-screen and buffered data to be stored in a data set (Figure 64 below).

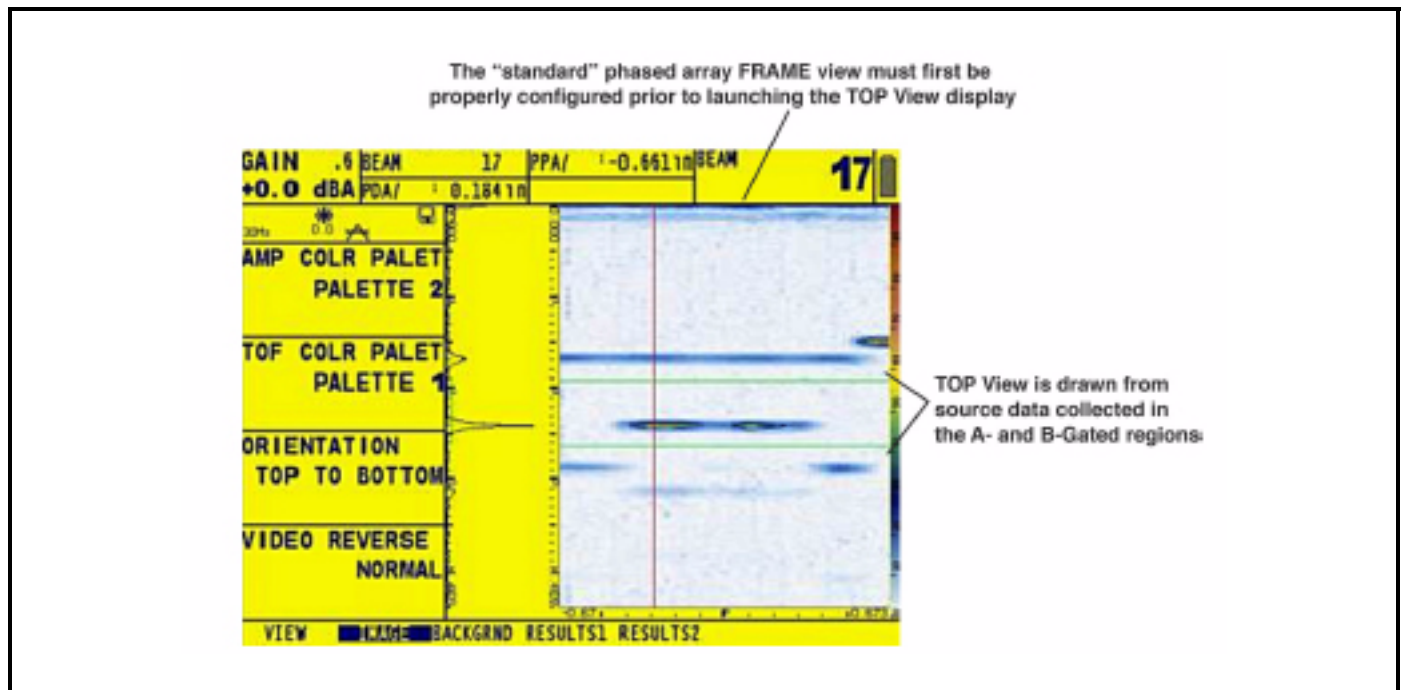







Figure 64: The A- and/or B-Gated regions in a sector or linear scan provide the data sources from which the TOP View display is generated.

7.1.2 Setting Up TOP View for TIMED, or TIMED CONTINUOUS Operation (cont.)

5. Press  to activate and set the NEW DATA Function in the IMAGE Submenu (located in the DISPLAY Menu). The selection sets the screen location (LEFT, RIGHT, TOP, or BOTTOM) at which newly acquired TOP VIEW data is added to the display screen. This function controls the display screen scrolling direction.
6. Press  to activate and set the AMP COLOR PALETTE in the IMAGE Submenu (located in the DISPLAY Menu). Select one of the four standard palettes to represent with various color scales the amplitude of echoes captured in A- or B-Gate. Alternatively, select CUSTOM to choose the user inputted, remotely generated, customized color palette.
7. Press  to activate and set the TOF COLOR PALETTE in the IMAGE Submenu (located in the DISPLAY Menu). Select one of the four standard palettes to represent with various color scales the time-of-flight measurement to the A- or B-Gate triggering echo. Alternatively, select CUSTOM to choose the user inputted, remotely generated, customized color palette.
8. Press  to activate and set the DATA SOURCE Function in the VIEW Submenu (located in the DISPLAY Menu). Select from four types of gated data to represent in the TOP View including:
 - AMP A – Amplitude of echoes captured in the A-Gate
 - AMP B – Amplitude of echoes captured in the B-Gate
 - TOF A – Time of flight duration to A-Gate triggering echoes
 - TOF B – Time of flight duration to B-Gate triggering echoes
9. Press  to activate TOP View by setting the VIEW MODE Function in the VIEW Submenu (located in the DISPLAY Menu) to TOP. The instrument will immediately begin acquiring data and filling the TOP View display.

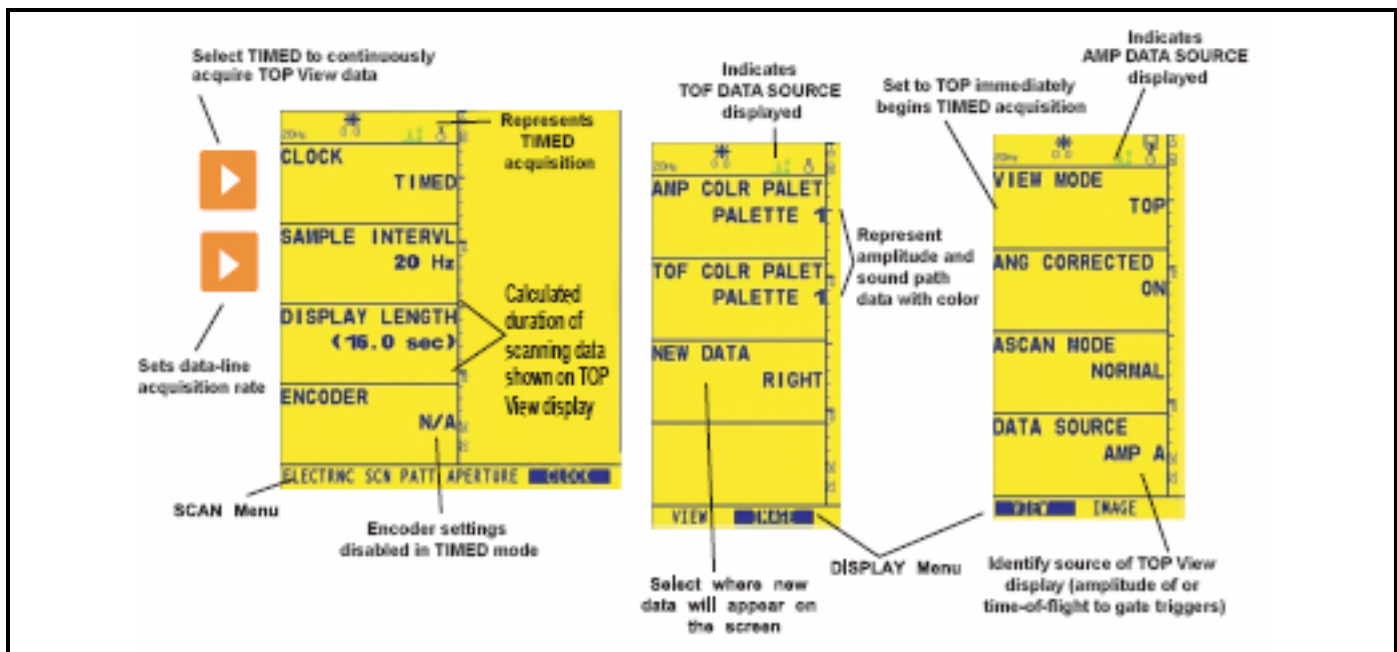

Figure 65: Make these settings for TIMED TOP View operation. Most TOP View specific settings are accessed from the CLOCK, VIEW, and IMAGE Submenus.

7.1.3 Setting Up TOP View for ENCODED Operation





Note: During TIMED TOP View operation, all functions can be accessed and changed.

In ENCODED operation (designated this because the probe operates in tandem with a single-axis quadrature encoder), the instrument acquires scan data whenever the encoder wheel is turning. The calculated DISPLAY LENGTH listed on the screen (when the CLOCK Submenu is activated) represents the approximate linear distance over which the probe can acquire data that is then represented on the TOP View display screen at one time. After the screen fills with data, and data continues to be acquired, the oldest data is added to the instrument's data buffer until the operator stops the process or the buffer is "full." This on-screen and buffered data is immediately viewable and can be stored to a data set.





Note: The TOP View quadrature encoder controls the collection of TOP View data in two ways. First, data is only collected while the encoder wheel is turning (i.e., while the probe is moving over the test piece). Second, the encoder allows data to be overwritten when its direction of travel is reversed. For instance, moving the probe and encoder forward over a distance of 10 cm, then reversing the probe's movement by 2 cm, will cause the last 2 cm of forward-moving data to be replaced by the 2 cm of reverse-moving TOP View data.

Refer to Figure 66 on page 150 and follow these steps to configure the instrument for TOP View operation in ENCODED mode. The resulting TOP View operation is shown in Figure 68 on page 154.

Note: While scanning in ENCODED mode, TOP View data is first added to the display screen. When the screen is full, the initial data "scrolls" into the instrument's data buffer. Scrolling direction is defined in Step 5. **When the buffer is full the scanning process automatically stops**, requiring the operator to take action before the buffer is overwritten. At any time, the TOP View scanning process can be stopped, allowing on-screen and buffered data to be stored in a data set (Section 7.4).

1. Press  to activate the VIEW MODE Function in the VIEW Submenu (located in the DISPLAY Menu). Set its value to FRAME.
2. Press  to activate and set the NEW DATA Function in the IMAGE Submenu (located in the DISPLAY Menu). The selection sets the screen location (LEFT, RIGHT, TOP, or BOTTOM) at which newly acquired TOP VIEW data is added to the display screen. This function controls the display screen scrolling direction.
3. Press  to activate and set the AMP COLOR PALETTE in the IMAGE Submenu (located in the DISPLAY Menu). Select one of the four standard palettes to represent with various color scales the amplitude of echoes captured in A- or B-Gate. Alternatively, select CUSTOM to choose the user inputted, remotely generated, customized color palette.
4. Press  to activate and set the TOF COLOR PALETTE in the IMAGE Submenu (located in the DISPLAY Menu). Select one of the four standard palettes to represent with various color scales the time-of-flight measurement to the A- or B-Gate triggering echo. Alternatively, select CUSTOM to choose the user inputted, remotely generated, customized color palette.
5. Press  to activate and set the DATA SOURCE Function in the VIEW Submenu (located in the DISPLAY Menu). Select from four types of gated data to represent in the TOP View including:
 - AMP A – Amplitude of echoes captured in the A-Gate
 - AMP B – Amplitude of echoes captured in the B-Gate
 - TOF A – Time of flight duration to A-Gate triggering echoes
 - TOF B – Time of flight duration to B-Gate triggering echoes

7.1.3 Setting Up TOP View for ENCODED Operation (cont.)

6. Activate the CLOCK Submenu (located in the SCAN Menu) by pressing  below it.
7. Press  to set the CLOCK Function to ENCODED. Input the operating characteristic (inches or mm per encoder “tick”) of the attached encoder using the ENCODER Function.
8. Press  and turn the Function Knob to set the SAMPLE INTERVL (in mm or inches). This equates to the distance traveled by the probe’s encoder wheel between lines of acquired data.
9. Note that the calculated value of DISPLAY LENGTH automatically updates. This represents the approximate linear distance over which an encoded scan can be acquired and represented on the TOP View display at the same time. While scanning a test piece, stopping the display (Section 7.3) allows the operator to scroll back through the acquired TOP View data.
10. Press  to activate TOP View by setting the VIEW MODE Function to TOP.

Note: The instrument will only update the data display while the encoder’s wheel turns.

7.1.4 Encoder Calibration

To ensure proper setup of the encoder/wheel combination it is recommended to perform an encoder calibration over a known distance. Encoder calibration can only be performed while the instrument is in ENCODED TOP VIEW mode.

1. Activate ENCODER Top View
2. In the SCAN-ENC CAL menu, set CAL SCAN LEN value to the distance over which the encoder calibration will be performed.
3. Position the probe/encoder at the start position of the calibration distance.
4. Press the START parameter. Move the probe/encoder to the end of the calibration distance.
5. Press the FINISH parameter. The encoder resolution will be set automatically.

Note: No image data will be displayed while performing an encoder calibration. Any data in the top view buffer will be lost once an encoder calibration is started.

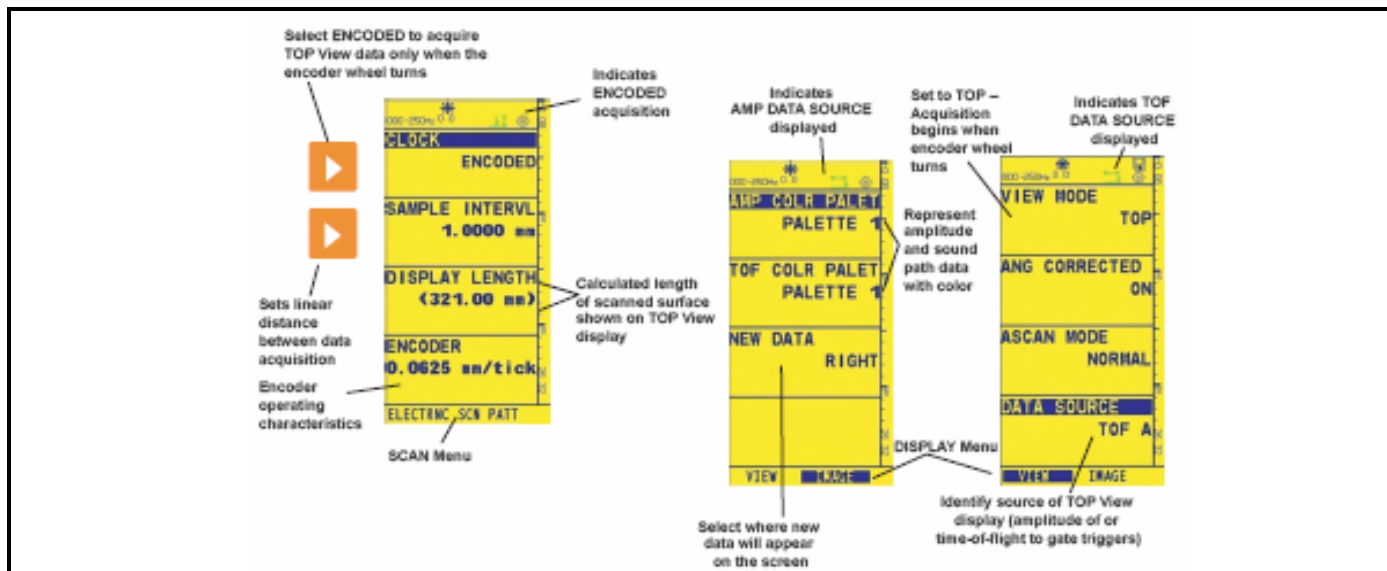

Figure 66: Make these settings for TOP View operation with an encoder. Most TOP View specific settings are accessed from the CLOCK, VIEW, and IMAGE Submenus.

7.2 Creating a TOP View

Whether in TIMED or ENCODED operating mode, the TOP View feature allows the user to acquire data over a period of time while scanning an area of interest. One of four data-viewing options (identified as DATA SOURCES in the VIEW Menu) is displayed as it is acquired. The remaining DATA SOURCES are automatically added to the instrument's data buffer from which they can be retrieved and viewed at any time (during TIMED mode) or when the instrument is STOPped (Section 7.3) in ENCODED mode. While acquiring TOP View data, the KNOB EMULATOR / TOP View Control Menu (identified in Figure 68 on page 154) includes controls that affect the scanning process; however, only the STOP operation is enabled while acquiring data in ENCODED mode.

Note: During TIMED TOP View operation, all functions can be accessed and changed. However, during ENCODED acquisition, most functions are blocked from change. Therefore, most instrument settings that are specific to TOP View must be adjusted in TIMED mode prior to switching to ENCODED mode.

Acquiring TOP View Data in TIMED Mode

After the instrument is configured as described in Section 7.1.1 and Section 7.1.2, the TOP View display is immediately active when the VIEW MODE Function (in the VIEW Submenu) is set to TOP. TIMED operation is shown in Figure 67 on page 151

Note: While scanning in TIMED CONTINUOUS mode TOP View data is first added to the display screen, which contains approximately the duration of data listed in the DISPLAY LENGTH Function box. When the screen is full the initial data "scrolls" into the instrument's data buffer. **New data automatically causes the oldest data in the buffer to be overwritten in TIMED CONTINUOUS.** At any time, the TOP View scanning process can be stopped, allowing on-screen and buffered data to be stored in a data set (Section 7.4). Storing data in a data set or generating a report clears the data buffer. Therefore, if immediate data analysis is desired, this should be performed before the file ACTION is taken. Alternatively, the stored data set can later be RECALLED to allow for analysis.

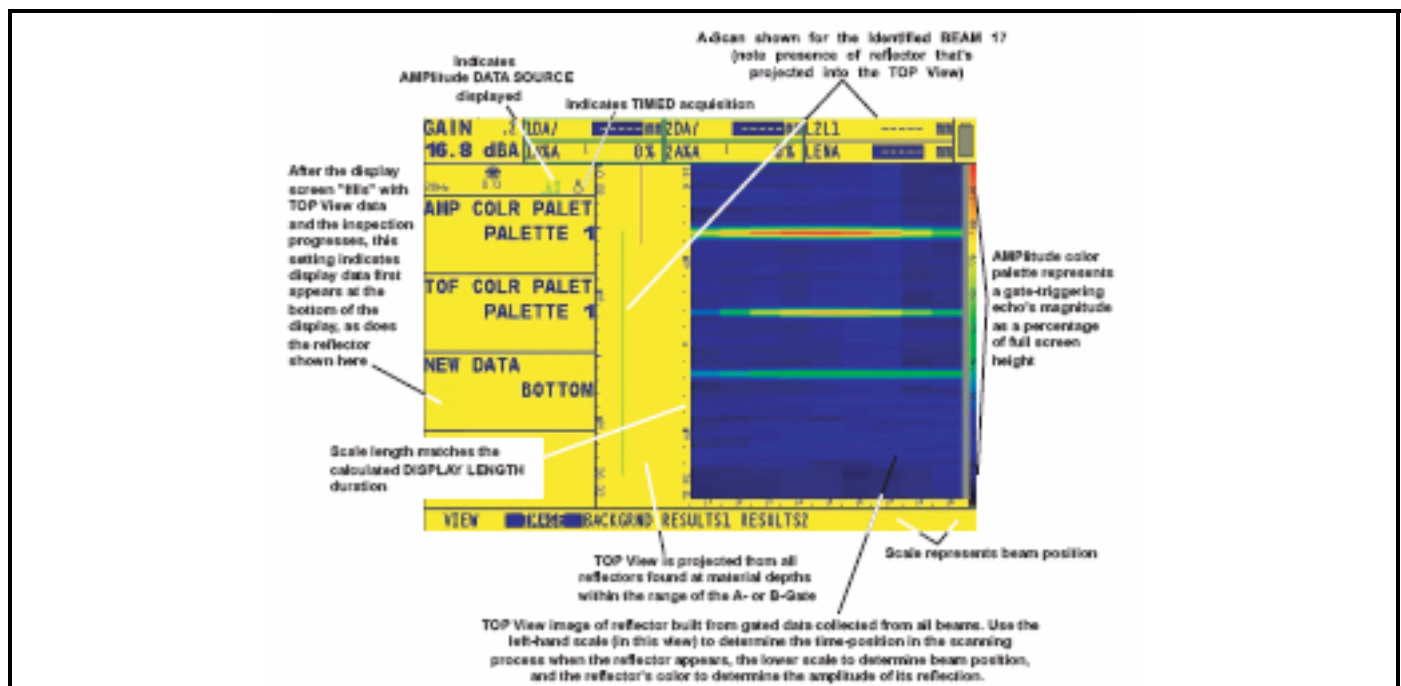

Figure 67: TOP View display data, in this case acquired in TIMED mode, represents the projection of reflectors from a region of interest (defined by the A- or B-Gate) onto a viewable plane. The TOP View display's detailed on-screen graticule and scale aids in determining a reflector's size and depth within the test piece.



Acquiring TOP View Data in ENCODED Mode



After the instrument is configured as described in Section 7.1.1 and Section 7.1.3, the TOP View display is *not* immediately active when the VIEW MODE Function (in the VIEW Submenu) is set to TOP. Instead, the instrument acquires data *only* while the encoder’s wheel is turning. This feature limits collection of TOP View data to only those time periods during which the probe is moving over the test piece surface. ENCODED operation is shown in Figure 68 on page 154.

Note: *While scanning in ENCODED or TIMED mode, TOP View data is first added to the display screen, which contains data acquired while the scanning the approximate distance listed in the DISPLAY LENGTH Function box. When the screen is full, as it is in Figure 68, the initial data “scrolls” into the instrument’s data buffer. When the buffer is full the scanning process automatically stops, requiring the operator to take action before the data is overwritten. At any time, the TOP View scanning process can be stopped, allowing on-screen and buffered data to be stored. Storing the data in a data set erases the data buffer. Therefore, if analysis and review of acquired data is to be performed directly on the instrument, it should be accomplished before the data set is stored (Section 7.4).*

Note: *The TOP View quadrature encoder controls the collection of TOP View data in two ways. First, data is only collected while the encoder wheel is turning (i.e., while the probe is moving over the test piece). Second, the encoder allows data to be overwritten when its direction of travel is reversed. For instance, moving the probe and encoder forward over a distance of 10 cm, then reversing the probe’s movement by 2 cm, will cause the last 2 cm of forward-moving data to be replaced by the 2 cm of reverse-moving TOP View data.*

Accessing the TOP View Control Menu

When TOP View mode is initiated, the Knob Emulator/ TOP View Control Menu is displayed. While this menu is displayed, the knobs are disabled. In TIMED mode, parameters can be adjusted by pressing  below KNOB+ or KNOB-. Pressing any other non-menu key (such as ) enables the knobs and “hides” the TOP View Control Menu. While acquiring data in ENCODED mode, only the  key below STOP is enabled.

While operating in TOP View mode, pressing  switches the display’s menu bar from any currently active menu to the Knob Emulator/TOP View Control Menu. This menu, shown in Figure 68 on page 154, allows the screen to be frozen by pressing  below STOP, or (in TIMED mode only) cleared by pressing  below CLEAR. It also allows the display to be cleared and restarted or to resume data collection from the point at which it was stopped. See Section 7.3 to work with a frozen TOP View Display or Section 7.4 to store the acquired TOP View data in a data set.

Selecting the TOP View DATA SOURCE

At any time when operating in TIMED mode (or when the display is frozen in ENCODED mode), the displayed TOP View data can be modified using the DATA SOURCE Function (accessed via the VIEW Submenu in the DISPLAY Menu). Note that options include:

- AMP A – Amplitude of A-Scan echo triggering A-Gate
- AMP B – Amplitude of A-Scan echo triggering B-Gate
- TOF A – Sound path distance to A-Gate triggering echo
- TOF B – Sound path distance to B-Gate triggering echo

Refer to Figure 68 on page 154 to see the icons used to indicate whether TOP View is operating in amplitude or TOF mode. These four data sources are also the only data related to the TOP View display that can be accessed from a frozen display (Section 7.3) or stored in a data set (Section 7.4).

7.2 Creating a TOP View (cont.)

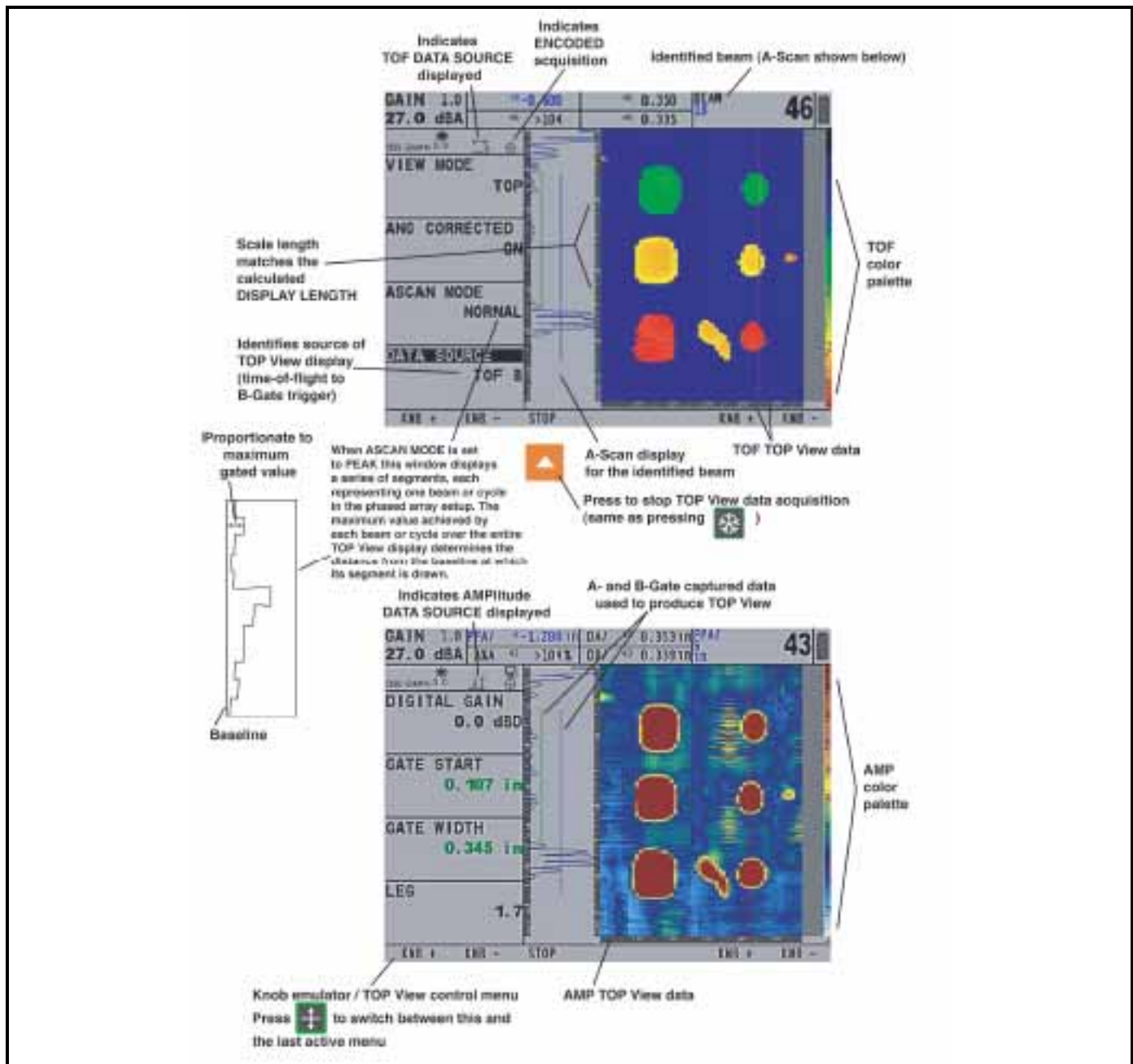



Figure 68: TOP View data, acquired in ENCODED mode, can be viewed as an amplitude or sound-path-distance to trigger (TOF) in A- or B-Gate.

Adding or Removing the A-Scan from the TOP View Display

While acquiring TOP View data, the A-Scan representing a selected beam can be displayed on the screen, along with the TOP View image. Note that if acquiring data in ENCODED mode, this function must first be set in TIMED mode before activating ENCODED mode. Press  to select the desired display view from:

- A-Scan and TOP View
- TOP View only

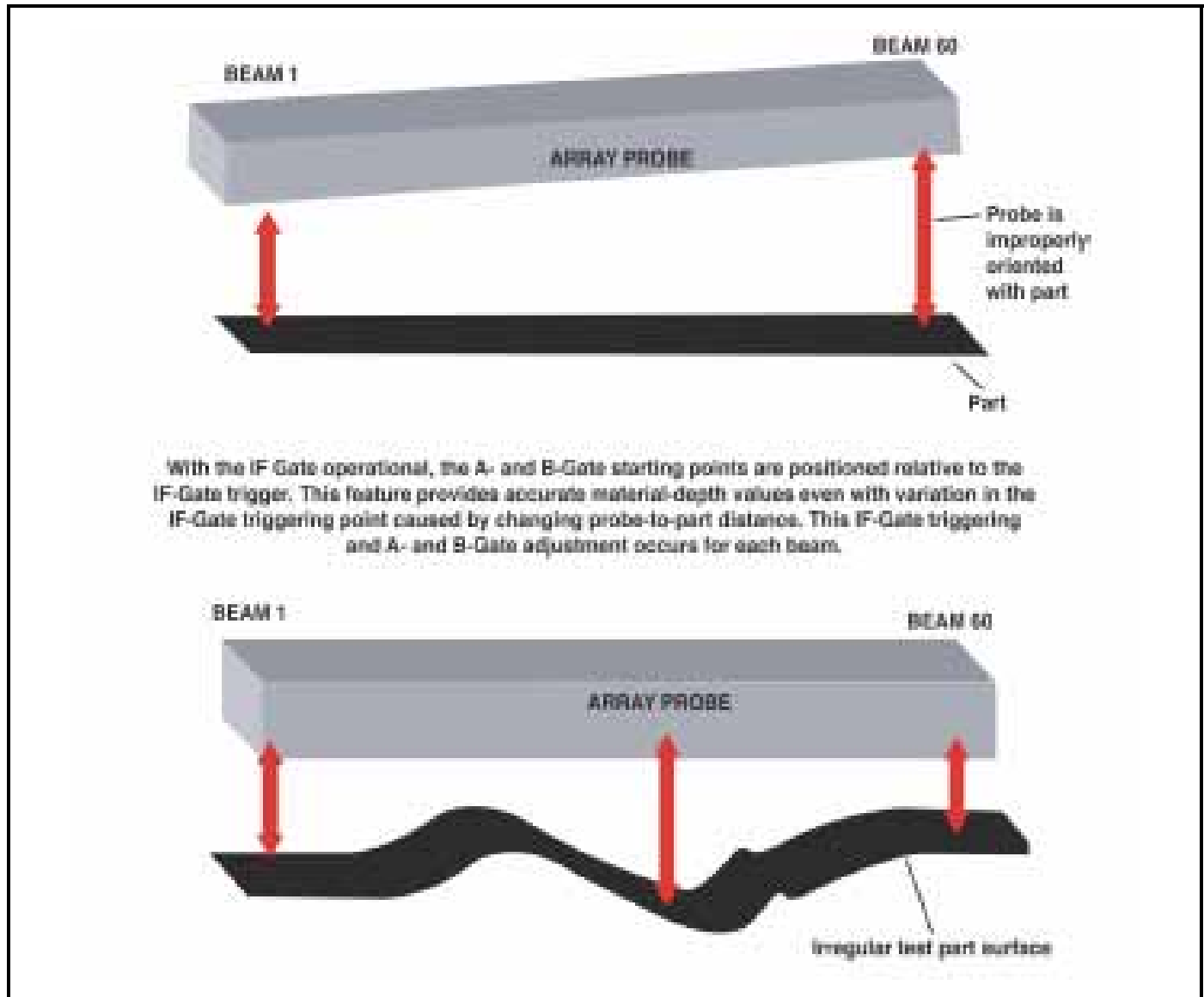

Figure 69: A and B-Gate Starting Points for Beams

Using the IF GATE in TOP View Mode

The interface (IF) GATE's primary function is to compensate for varying probe-to-test-piece distance by adjusting the A- and B-GATE starting points.

Variations of this distance occur either because of miss-orientation of the part relative to the probe or because the surface of the part is irregular. These variations are possible when a water gap is employed for coupling or when soft material is used.

Note: While highly infrequent, extreme temperature variation will change this probe-to-test-piece distance by altering ultrasonic velocity through the delay material.

Phased-array probes typically produce multiple beams, each of which can produce a slightly different reflector distance. Therefore, an IF-, A-, and B-Gate triggering occurs for each beam. GATE positions for each beam determine the test-piece area evaluated for transfer to the TOP View display. If improperly oriented probes or surface irregularities were not accounted for by adjusting the A- and B-Gate starting points, the material depth of interest may not be evaluated.

With the Interface GATE display switched to ON, A- and B-Gate's starting positions are automatically based on the occurrence of an IF-Gate triggering. This occurrence becomes the zero point from which A- and B-Gate starting values are measured (Figure 69 on page 155).

For example if A-Gate's START is set to 1 inch, the gate will start the equivalent of 1 inch from the IF-Gate trigger for each BEAM. If the probe-to-part distance changes, the A-Gate START point will automatically adjust accordingly. In addition, this adjustment will take place independently for each beam. This positions the A-Gate, in this case, at a fixed distance from the sound entry surface in the test piece, insuring the desired material depth is being evaluated.



IF loss can occur from loss of coupling, or when the distance from the probe to the part exceeds an acceptable limit. Limits are established to insure the phased array delay law calculations remain valid for the beam. The variations described effect this Phased Array delay law calculation, for both angle steering and focal depth. Delay law calculations are based on an assumed "Z" distance (Section 2.3.3).

Note: When operating in TOP View mode with the IF-Gate turned on, a loss of the interface signal will prevent the the offending beam from recording data to the TOP View. Instead, the operator is alerted to the condition with the application of a special IF LOSS color to the TOP VIEW Image.







Note: Turing ON the IF-Gate also impacts control of the DISPLAY START function. Refer to Section 2.6.3 to define the display's starting point with and without the IF Gate on.

Additionally, there is a DISPLAY START control related to the IF GATE. The choices are IF, IP and MATERIAL.



7.3 Freezing the Display and Navigating Data in TOP View



While operating in TIMED TOP View mode, the Knob Emulator/TOP View Control Menu can be turned on or off by pressing . As shown in Figure 70 on page 158, this menu pauses, clears, and restarts the TOP View data acquisition process. Pressing  below STOP (this is the only menu selection that's also active in ENCODED mode) has the same effect as pressing : the display is frozen and available for analysis or storage in a data set. To navigate and evaluate a frozen TOP View display, follow the steps below and refer to Figure 70:

Note: *While scanning in ENCODED mode, TOP View data is first added to the display screen, then scrolled into the instrument's data buffer. When the buffer is full the scanning process automatically stops, activating the Frozen TOP View Menu (Figure 70) and requiring the operator to take action before the data is overwritten. Saving this data to a data set file, generating a report, or otherwise carrying out an ACTION indicated in the FILES Menu clears the buffer.*

Note: *The TOP View Control Menu is activated and deactivated by pressing . When the Control Menu is active, the function keys and both knobs are disabled, but pressing  or  (in TIMED MODE) provides immediate access to various HOME-Menu functions. Similarly, when acquiring data in ENCODED mode (during which no function adjustments are allowed), pressing  below STOP and pressing  or  provides access to several functions that require recalculation of instrument parameters. As this recalculation will result in a clearing of unsaved TOP View data, the operator is asked to confirm this action before proceeding.*

Note: *Stopping the data acquisition process and saving this data to a data set file, generating a report, or otherwise carrying out an ACTION indicated in the FILES Menu clears the buffer.*

Note: *Pressing  below CLEAR (TIMED mode only), while the TOP View is acquiring data, immediately eliminates all unsaved TOP View data and restarts the display acquisition process. When the TOP View display is STOPped (or frozen), pressing  below START also eliminates all unsaved TOP View data and restarts the display acquisition process while RESUME (not displayed when the ENCODED mode buffer is full) allows the acquisition to continue from its position when STOP was selected.*

1. With TOP View operating and the TOP View Control Menu displayed (Figure 70), press  below STOP to freeze the TOP View display (pressing  has the same effect).

2. The Frozen TOP View Menu appears (Figure 70). Choose from the following menu selections:



CURSORS – Allows for left and right knob control of cursor 1 or cursor 2. All measurement of displayed TOP View data is made according to these two cursors

VIEW – Chose for display one of the four TOP View DATA SOURCES. Shows all acquired TOP View data on one screen or reverts to the scale used during data acquisition. Scrolling is only enabled when the VIEW WINDOW is set to AS ACQUIRED.



MEAS 1 and MEAS 2 – Select up to six measurement options that correspond to the two values specified by cursor 1's and cursor 2's position.

FILENAME – Sets the data set- and report-saving parameters, then stores data sets or generates reports. Note that pressing and holding  for approximately three seconds will cause a REPORT to generate or a DATA SET to be stored based on the ACTION setting.

7.3 Freezing the Display and Navigating Data in TOP View (cont.)

- Press  at any time to access the TOP View Control Menu. Press  below START to eliminate all unsaved TOP View data and restart the display acquisition process. Alternatively, press  below RESUME (if displayed) to continue the acquisition process from the point at which it was STOPped.

Note: When the TOP View display is frozen, switching the acquisition mode from TIMED to ENCODED (or vice versa) will result in a loss of data. Data to be retained must be stored in a data set prior to changing the CLOCK setting. Similarly, selecting and altering functions that require a recalculation of instrument parameters will result in loss of unsaved TOP View data.

Note: Pressing  below CLEAR, while the TOP View is acquiring data in TIMED mode, immediately eliminates all unsaved TOP View data and restarts the display acquisition process. When the TOP View display is STOPped (or frozen), pressing  below START also eliminates all unsaved TOP View data and restarts the display acquisition process. Pressing  below RESUME (if displayed) continues the acquisition process from the point at which it was STOPped.

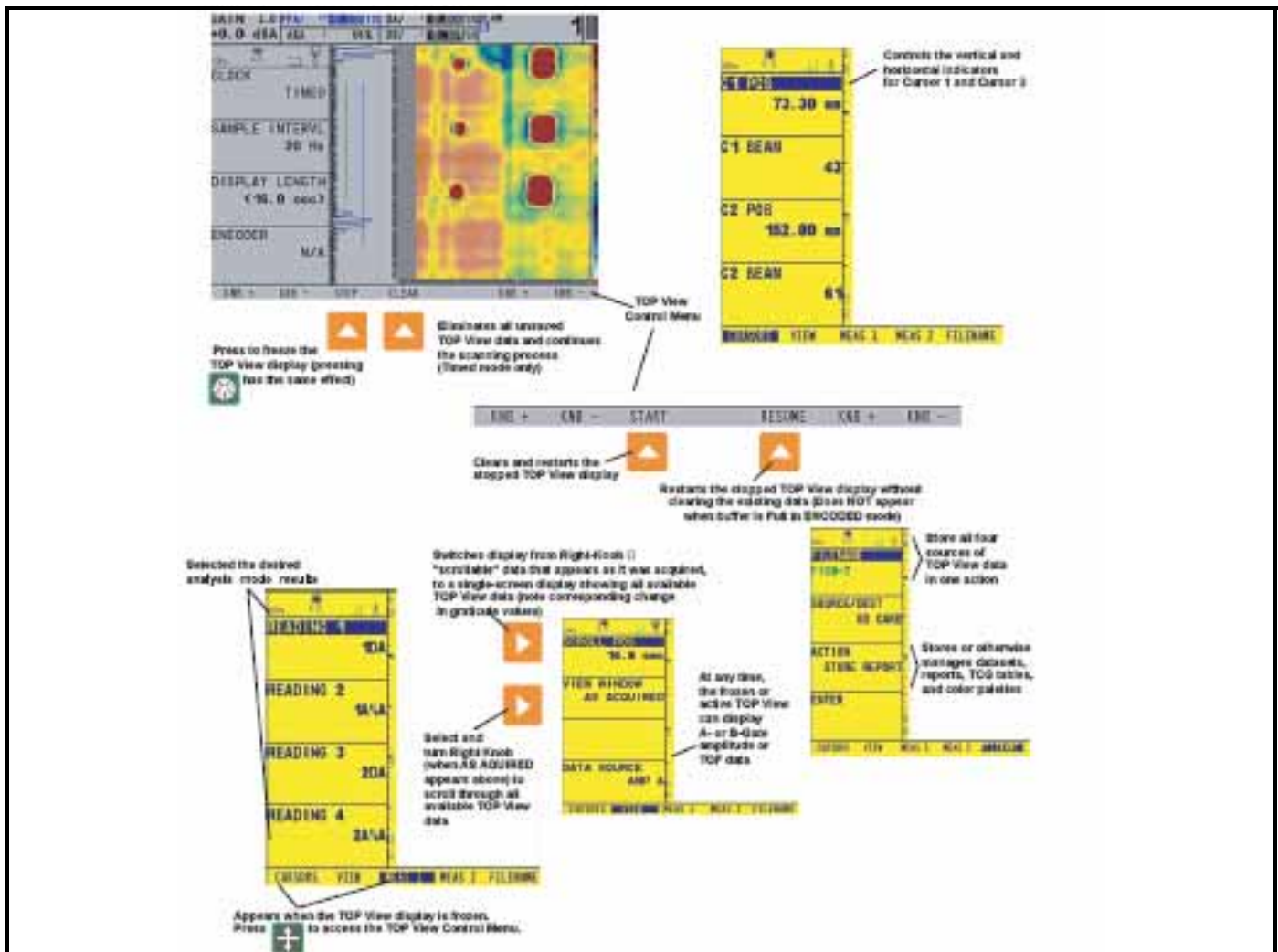

Figure 70: TOP View data can be viewed as an amplitude or sound-path-distance to trigger (TOF) in A- or B-Gate. Note that in ENCODED mode, DATA SOURCE changes can only be made when the display is frozen.

GATE A - Readings for all beams

- 1A%A, 2A%A Amplitude (as a % of full-screen height) of the echo in gate A for the data sample selected by cursor 1 or 2 respectively. 1SA, 2SA Soundpath of the echo in gate A for the data sample selected by cursor 1 or 2 respectively.
- 1DA, 2DA The volume corrected depth of the reflector in gate A for the data sample selected by cursor or 2 respectively.
- 1PA, 2PA Project distance from the specified origin of the reflector in gate A for the data sample selected by cursor 1 or 2 respectively
- 1ZA, 2ZA Uncorrected depth of the reflector in gate A for the data sample selected by cursor 1 or 2 respectively.
- OTA Percentage over gate A threshold for all samples in the top view scan
- OTPA Percentage over gate A threshold for samples between position cursors
- OTCA Percentage over gate A threshold for samples between both position and beam cursors
- C21_B2B1 Distance between beams. Available for probe scans of straight beam (0-degree) linear scans.

GATE B - Readings for all beams

- 1A%B, 2A%B Amplitude (as a % of full-screen height) of the echo in gate B for the data sample selected by cursor 1 or 2 respectively.
- 1SB, 2SB Soundpath of the echo in gate B for the data sample selected by cursor 1 or 2 respectively.
- 1DB, 2DB The volume corrected depth of the reflector in gate B for the data sample selected by cursor 1 or 2 respectively.
- 1PB, 2PB Project distance from the specified origin of the reflector in gate B for the data sample selected by cursor 1 or 2 respectively
- 1ZB, 2ZB Uncorrected depth of the reflector in gate B for the data sample selected by cursor 1 or 2 respectively.
- OTB Percentage over gate B threshold for all samples in the top view scan
- OTPB Percentage over gate B threshold for samples between position cursors
- OTCB Percentage over gate B threshold for samples between both position and beam cursors

GATE A - Readings for selected beam

- L2L1 The distance between the position of cursor 1 and cursor 2 along the scan axis. The value is displayed as time or distance depending on the clock mode.
- DPA The difference between the 1PA and 2PA results.
- DDA The difference between the 1DA and 2DA results.
- DPB The difference between the 1PB and 2PB results.
- DDB The difference between the 1DB and 2DB results.
- LENA The distance through the three dimensional ultrasonic data space from the indicator in gate. A selected by cursor 1 and the indicator in gate A selected by cursor 2. This value is only displayed for encoded top view data.

7.3 Freezing the Display and Navigating Data in TOP View (cont.)

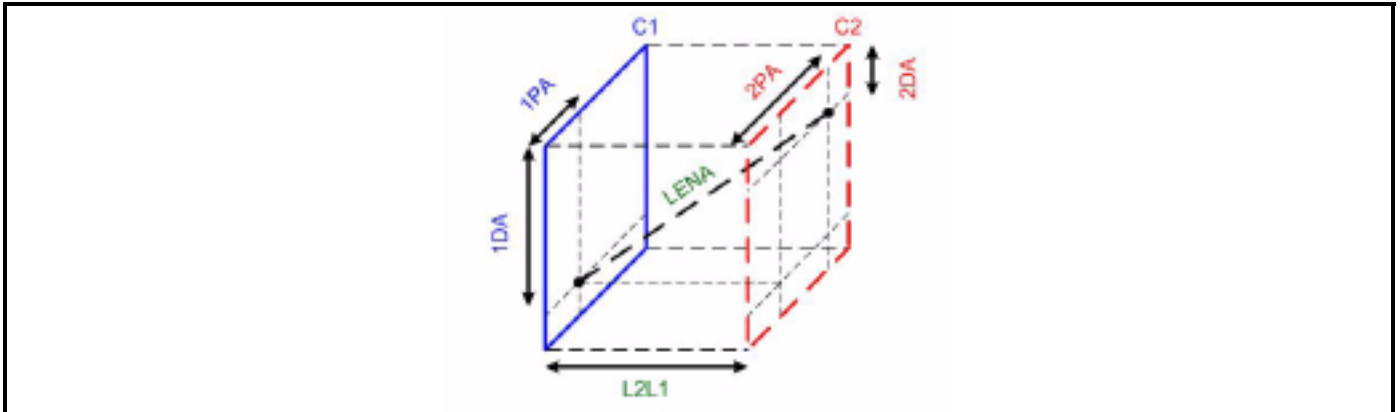

Figure 71: LENA, the distance through the three dimensional ultrasonic data space from the indicator in gate.

The End of the scan

The scan will stop at the press of the **+** FREEZE key. If in the Test menu, pressing STOP will end the scan. In ENCODED or TIMED clock mode when the data buffer is full, the scan will stop automatically.

The VIEW WINDOW is AS ACQUIRED and the SCROLL POS is set to the end of the scan (minus the image width).

The position cursors (C1 POS and C2 POS) are set at the same position—in the middle of the data that is on screen.

The beam cursors (C1 BEAM and C2 BEAM) are set on the same beam--the selected beam of the scan.

To Review all Data and Size Defects

1. Select the VIEW menu and change VIEW WINDOW to VIEW ALL.
2. To size a defect, return to CURSORS menu and set C1 POS and C2 POS at each end of the defect.
3. To make sure the cursors are positioned exactly, change VIEW WINDOW to AS ACQUIRED.
4. The instrument automatically sets the SCROLL POS so that the C1 POS cursor will appear centered on the image.
5. To make a fine adjustment of C1 POS, place the cursor at the edge of the defect.
6. If the other end of the defect (the C2 POS end) is off screen, go to the VIEW menu and adjust SCROLL POS to scroll to the other end of the defect where C2 POS is located.
7. Make the fine adjustment of C2 POS necessary to place the cursor at the edge of the defect.

Alternative Defect Sizing Approach

Use this technique if the end of the defect is on screen at the end of the scan.

1. Position the C2 POS cursor at the end of the defect on the screen.
2. Position C1 POS cursor at the start of the defect by moving the cursor toward the start of the data. If the start of the defect is off-screen, the data window will scroll with the movement of the cursor.

Cursor Behavior when the View Window is AS ACQUIRED

The C1 POS will scroll the window similar to the SCROLL POS functions.



The C2 POS cursor may only be positioned in the current image area.

When the cursor is off-screen, the cursor is not shown. Both the position and beam cursor lines are hidden.



When a cursor is off-screen, a change to the position value (C1 POS or C2 POS) will cause the cursor to snap to the side of the image closest to the previous cursor position. To avoid this, use the SCROLL POSITION in the VIEW menu to move the data window to bring the cursor on screen.

7.4 Storing the TOP View Data

TOP View data can be stored directly in a data set. All four TOP View DATA SOURCES are held in the data set. When retrieved, all data analysis described in Section 7.3 can be conducted on the TOP View data. Note that the stored data set will not include A-Scans.

While TOP View mode is active, press  or press  below STOP to freeze the display. This activates the Frozen TOP View menu (shown in Figure 70 on page 158). Set the ACTION Function (located in the FILE Menu) to STORE DATA SET and continue the data set storing process (as described in Section 6.1). Alternatively, after the ACTION Function is set to STORE DATA SET, press and hold  (at any time) for three seconds to store the data set.

Similarly, setting the function to STORE REPORT and holding  generates a report. This storing process automatically increments the data set's or reports filename. Note that the data acquisition process is interrupted while carrying out this ACTION and the TOP View data buffer is cleared.

Note: Pressing  below CLEAR, while the TOP View is acquiring data, immediately eliminates all unsaved TOP View data and restarts the display acquisition process. When the TOP View display is STOPped (or frozen), pressing  below START also eliminates all unsaved TOP View data and restarts the display acquisition process. Pressing  below RESUME (when displayed) continues the acquisition of additional data.

Note: When the TOP View display is frozen, switching the acquisition mode from TIMED to ENCODED (or vice versa) will result in a loss of data. Data to be retained must be stored in a data set prior to changing the CLOCK setting. Similarly, selecting and altering functions that require a recalculation of instrument parameters will result in loss of unsaved TOP View data.

7.5 Using TOP View's ENCODED Mode – User Application Summary

A typical TOP View data-acquisition session may be conducted in the following manner:

- A probe is selected to cover an area of test material with multiple straight beams. Suitable coupling is chosen and an appropriate ultrasonic setup is performed on the instrument.
- While the instrument is still in FRAME VIEW mode, ENCODER details are supplied to the Phasor in the CLOCK menu and the gates are positioned to identify the area of interest to be displayed on the TOP View.
- The CLOCK Function (in the SCAN Menu) is set to TIMED, and TOP View selected. A trial test is performed to satisfy the operator that settings result in the desired TOP View. *If* this is not the case, the operator can return to FRAME view and make adjustments. Alternatively, some adjustments can be made during this TIMED TOP View session including gate, gate position, TCG band pass controls, and others.
- After all adjustment are made, the operator then switches to encoded mode, presumably with the intent of storing the acquired data.
- The test piece is scanned until the area is covered or the buffer is filled, whichever comes first.
- If the scan is completed before the buffer is full, the operator selects STOP or presses .
- At this point, acquired data can be analyzed, immediately stored to, or discarded.
- If the data is stored in a data set, it can *not* be immediately analyzed the data at that time, and must instead be analyzed after a recalling of the data set.
- From the TOP View Control Menus, the operator can select START to begin a new acquisition session, or change back to FRAME view for closer inspection of a selected region, or select TIMED mode to adjust settings prior to creating a new image.

[no content intended for this page - proceed to next page]

Chapter 8. Making Custom Corrosion Measurements

For Phasor XS users, depth measurement (DM) is a custom application supported through the use of specific POP files designed for use with dual linear corrosion array probes. To support custom applications, the Phasor XS must include a “Custom” option; users who purchase special probes that require the custom option, such as the dual linear corrosion array probes, will have this option enabled. To determine if the option is enabled on your instrument, look for the entry “Custom” in the CONFIGURATION list on the startup splash screen or the “CUSTOM” selection in the Welcome menu.

8.1 Doubling

Ultrasonic thickness gauges will, under certain conditions, display readings which are twice (or, in some cases, three times) the actual material thickness being measured. This effect, commonly known as “doubling,” can occur below the minimum specified range of the transducer. If the transducer being used is worn, doubling is possible at a thickness greater than the minimum of the specified range.

When using a new transducer, any reading which is less than twice the minimum specified range of the transducer may be a “doubled” reading, and the thickness of the material being tested should be verified by the use of other methods. If the transducer shows any sign of wear, doubling may occur at a second echo or other echo signal combinations may produce a readable signal. The instrument reading and apparent thickness are up to about twice the actual value, resulting in a thickness greater than twice the minimum of the specified range. This thickness should be determined by calibrating the instrument/transducer combination on reference blocks that represent the complete range of possible thicknesses that may be encountered in testing. This is particularly important when the test piece is being ultrasonically measured for the first time or in any case where the history of thickness of the test specimen is unknown.

8.2 Calibrating a Custom Instrument/Probe Combination

Calibrating the linear array supplied for thickness measurement begins by loading the custom file associated with the probe to be used. Each probe has an operating file named according to the order code of the probe. For example, the file “115-000-765.5 EL” drives the probe with 5 elements in each shot. A corresponding file for this probe ends with “3 EL”; this file drives a 3 element group.

***IMPORTANT:** The Phasor XS may fail if a user removes or attaches the probe while the instrument is running. If this occurs, the user will lose any unsaved settings. To protect against this failure, GE recommends that the user power OFF the instrument before attaching or replacing a probe.*

After a user chooses CUSTOM on the Welcome screen, the Phasor XS will present a special File menu. The custom application File menu offers four commands:

- FILENAME to allow the user to scroll through the list of files available on the source drive.
- SOURCE/DEST to allow the user to choose INT MEMORY, DIALOG PROBE or SD CARD. The default SOURCE/DEST will always be “DIALOG PROBE”
- ACTION fixed to RECALL DATASET
- ENTER to execute the command

Load the file associated with the probe attached by using the **RECALL DATASET** command in the Files menu. The file is delivered either on an SD card or on the probe itself.

8.2 Calibrating a Custom Instrument/Probe Combination (cont.)

Select the appropriate SOURCE/DEST for this file (SD card or Dialog probe) and recall the file.

After the file is successfully recalled and the unit is active, you must perform a calibration to obtain correct thickness readings.

Adjust the GAIN so that the delay tip echo appears on the image as a faint blue line.

Note: Display of this delay tip echo is intended as an indication of PROBE wear. If this line is not visible, the probe may be worn past its usable limits. As the probe wears, this line will migrate off screen.

Recalling the original probe DATASET supplied with the probe should make the line visible again as PROBE DELAY value supplied (5.5 microseconds) shows available wear tolerance. If the line is not visible after recalling DATA SET for the probe, contact your service representative.

Adjust PROBE DELAY until the blue line is at the TOP of the screen, so that it is barely visible on the image.

Then proceed to “Two-Point Calibration for Probe Zero and Material Velocity” on page 167.

8.3 Two-Point Calibration for Probe Zero and Material Velocity

Two options are available for D-CAL: 2-POINT and 1-POINT.

- 2-POINT calculates material velocity and probe delay
- 1-POINT calculates probe delay only and should only be used after a 2-POINT has been performed (to re-adjust probe delay) or when the material velocity is known and has been entered.

8.3.1 2-POINT D-CAL

For recording of the 2-point calibration, use the 118-540-985 (inches) or 118-540-985 (metric) calibration block (sold separately by GE). GE recommends calibrating the instrument using these blocks. For recording the two points, place the probe on the thin and thick sample as shown in Figure 72 below. Each beam should “see” a reflection from the chosen thin reflector and the thick reflector.



Figure 72: Calibration Probes on 0.1-inch block and 0.5-inch block

Note: *If the wide block is not available, an alternate 2 point calibration technique calls for sliding the probe across a section of the required material, or for placement on a special calibration sample with sufficient area for reflections from the given thickness displayed by each beam, as shown in Figure 73 below. Each beam of the array must “see” a reflection from both the chosen thin reflector and the thick reflector. However, sliding the probe is not necessary if a sufficient area of thickness can be “seen” by all beams.*



Figure 73: Sliding the Probe Across the Sample Material

8.3.1 2-POINT D-CAL (cont.)

1. Press HOME, PART, D-CAL, 2-PT twice.
2. Input D-REF1 and D-REF2 (Figure 74 below).



Figure 74: D-REF1 and 2

3. Couple to the D-REF1 standard, and adjust the gain so that all beams break threshold but are not saturated (approximately 80% amplitude). Each beam must record a signal above gate threshold and not saturated for each point. If any beam does not record valid amplitude, a message will appear at the bottom of the screen. To achieve successful recording of the entire peak envelope on the display, raise the GAIN so that the PEAK goes above full screen height, then lower the gain until all beams are back on screen in the peak envelope. This procedure ensures that the first positive half wave amplitude is the one recorded for the calibration.

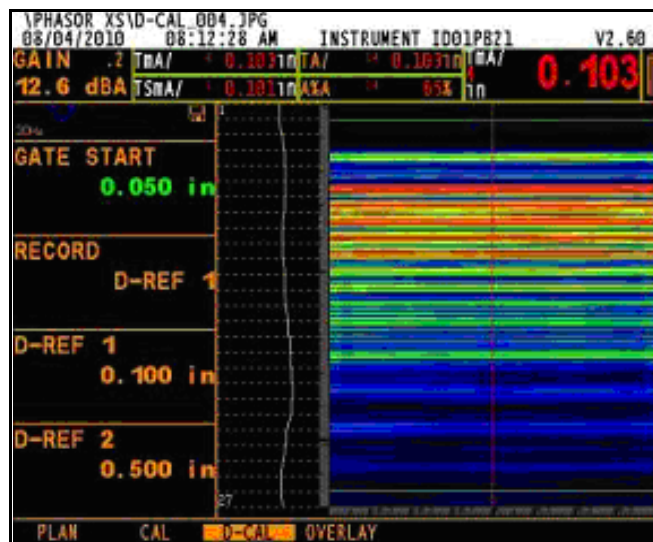

Figure 75: Adjusting the Gain for D-REF1 Standard

8.3.1 2-POINT D-CAL (cont.)

4. Press RECORD twice.
5. Couple to the D-REF2 standard, and adjust the gain so that all beams break threshold but are not saturated (approximately 80% amplitude). Each beam must record a signal above gate threshold and not saturated for each point. If any beam does not record valid amplitude, a message will appear at the bottom of the screen. To achieve successful recording of the entire peak envelope on the display, raise the GAIN so that the PEAK goes above full screen height, then lower the gain until all beams are back on screen in the peak envelope. This procedure ensures that the first positive half wave amplitude is the one recorded for the calibration.



Figure 76: Adjusting the Gain for D-REF2 Standard

6. Press RECORD twice. The D-CAL icon (Figure 77 below) will appear when the procedure is successfully completed.

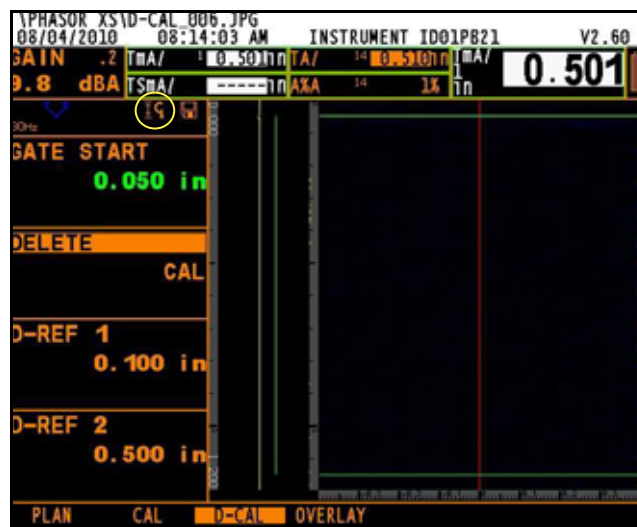

Figure 77: Selecting the D-CAL Icon

8.3.2 1-POINT D-CAL (Probe Delay or Probe Zero)

1. Press HOME, PART, and check the material velocity to be correct for the REF block (if not, input the velocity or perform a 2-POINT D-CAL first).
2. Press D-CAL.

Note: If D-CAL is already active, you must select DELETE (Figure 78 below) to deactivate the current D-CAL.



Figure 78: Delete Selection

3. Select 1-Point twice.
4. Input D-REF1.
5. Couple to the D-REF1 standard, and adjust the gain so that all beams break threshold but are not saturated (approximately 80% amplitude). Each beam must record a signal above gate threshold and not saturated for each point. If any beam does not record valid amplitude, a message will appear at the bottom of the screen. To achieve successful recording of the entire peak envelope on the display, raise the GAIN so that the PEAK goes above full screen height, then lower the gain until all beams are back on screen in the peak envelope. This procedure ensures that the first positive half wave amplitude is the one recorded for the calibration.

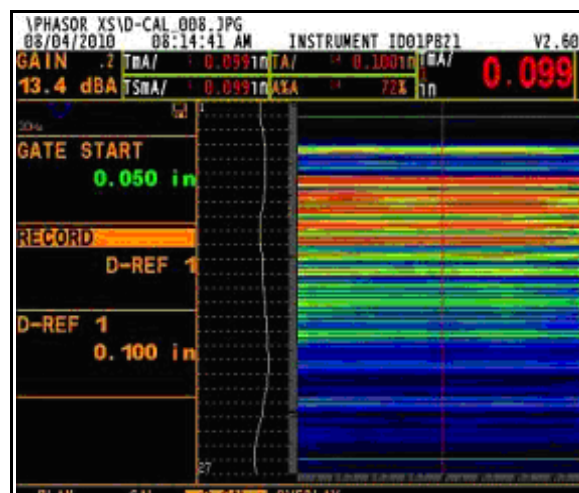

Figure 79: Adjusting Gain

8.3.2 1-POINT D-CAL (Probe Delay or Probe Zero) (cont.)

6. Press RECORD twice. The D-CAL Icon will appear when the procedure is successfully completed.

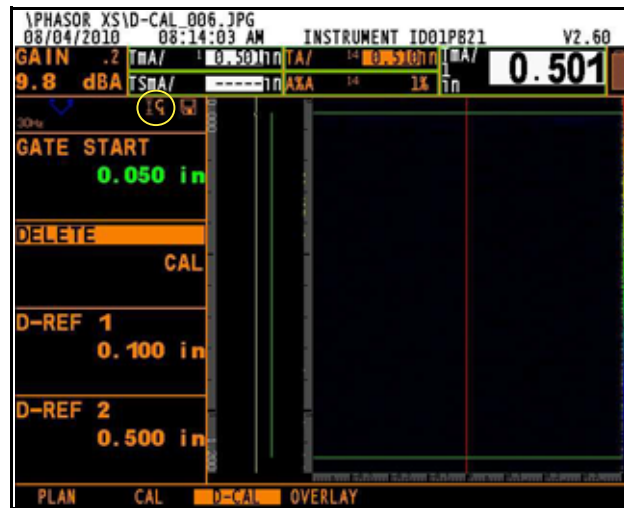

Figure 80: D-CAL Icon

8.4 Saving the Data to a Microsoft Excel™ File

Once you have taken the corrosion measurements, you can export the top view data to a file format that the user can load into Microsoft Excel or other tools.

8.4.1 Procedure

During custom measurement, users operate in Frame View mode (viewing the B-scan image), watching either the image or the minimum thickness results. If users see an area of concern, they locate the area of concern on the part, switch to encoded top view mode, scan the part, press **Stop**, and name and save the dataset to a POP file in the FILENAME menu. Users can then either continue scanning, or export the thickness readings to a log file immediately. After completing their measurements, if users did not already export the data, they may recall the dataset and export the data to a log file.

8.4.2 Setup

The DATA LOG menu in the FILES menu will allow the user to set some of the file attributes.

FILENAME	HEADER	MEMO	REPORT	DATA LOG
Filename	Header Number	Edit	Image in Report	Log Range
Source/Dest	Edit		Param in Report	Reading
Action	Hdr in Report			
Enter		Memo in Report		

8.4.3 Storing A Log File

To save the selected Top View data, users enter the Data Log menu to define the range and reading of the data, and then select “STORE DATA LOG” in the ACTION function of the FILENAME menu. The instrument will attempt to save the log file to the filename in the FILENAME field with the extension “.CSV”. If the file already exists, the Phasor will prompt the user to overwrite the file, or to press the HOME key to cancel saving.

Note: Users can only select SD CARD as the SOURCE/DEST; otherwise, the Phasor XS will display an error message.

Note: Once ACTION is set to “STORE DATA LOG” and SOURCE/DEST is set to “SD CARD”, a press and hold of the Freeze key will stop the top view scan (if not already stopped) and generate a log file with the same name as the dataset. Each subsequent press and hold of the Freeze key will automatically generate a numbered log file.

Within the Data Log menu, the LOG RANGE option defines how much data to export to the log file. Users can choose:

- **CURSOR RANGE**—exports the selected reading for only the scan positions between (and including) the CUR 1 POS and CUR 2 POS.
- **ALL DATA**—exports the selected reading for all scan positions within the Top View scan.

8.4.3 Storing A Log File (cont.)

For the option “CURSOR RANGE”, the user:

1. Adjusts the cursors to select a region of interest,
2. Sets the data logger parameter DATA REGION to “CURSOR RANGE”, and
3. Sets ACTION to “STORE DATA LOG” in the FILENAME menu to save the data to the CSV file.
4. Press and hold the Freeze key to save the file name with an autonumber sequence (from 0001 to 9999).

For the option “ALL DATA”, the user:

1. Sets the data logger parameter DATA REGION to “ALL DATA”, and
2. Sets ACTION to “STORE DATA LOG” in the FILENAME menu to save the data to the CSV file.
3. Press and hold the Freeze key to save the file name with an autonumber sequence (from 0001 to 9999)

The READING option defines which value to export to the log file. Users can select:

TA	TA for all beams, for each scan position in LOG RANGE
TB	TB for all beams, for each scan position in LOG RANGE
TBA	Difference between TB and TA for all beams, for each scan position in LOG RANGE
TA & TB	TA and TB for all beams, for each scan position in LOG RANGE

[no content intended for this page - proceed to next page]

Chapter 9. DGS in Phased Array Mode

For Phasor XS users, Distance Gain Sizing (DGS) evaluation in phased array is a custom application supported through the use of specific POP files programmed into the Phasor or into specific dialog probes. To support this application, the Phasor XS must include a “Custom” option. To determine if the option is enabled on your instrument, look for the entry “PA-DGS” on the startup splash screen.

Note: For a basic explanation of DGS, refer to Section 5.14.

9.1 Setting Up DGS Evaluation

To perform DGS evaluation:

1. From the Welcome menu, select CUSTOM (on startup or by pressing the MODE SELECT key .
2. At the custom file load menu, select and load a DGS setup file, either one already programmed into the dialog, or a user-created file.

When the user loads a PA DGS setup file (from the dialog probe only):

- The instrument will load the PROBEDEF.SYS file to set the probe-specific information (probe part number, serial number, frequency, number of elements, etc.) into the probe parameters. The software thus ensures that the probe part number and serial number are properly configured.
- The instrument will not verify that the probe part number of the setup file matches that of the PROBEDEF.SYS. The user must maintain proper setup files with dialog probes.
- The instrument will not load the PROBEDEF.SYS file when loading a POP file from the SD card. The user can manually load the PROBEDEF.SYS file by navigating to the PROBE→PRB DAT menu and choosing the DIALOG PROBE LOAD DEF action.

If you selected an existing DGS setup file, you can begin calibration and measurement.

If you have selected a new setup, the instrument will initialize all settings and provide the full angle range as programmed into the PROBEDEF.SYS file. You must adjust the range, gates, etc. for the desired inspection. You may also choose a different angle range for the sector scan, with restrictions (described later).

9.2 Dialog Probe Settings and POP Setup File

The PA DGS option will not contain a fixed table for each known probe as is available in the Conventional Channel. Instead, the probe information for the connected probe will come from the dialog memory device located in the probe connector.

In the PA DGS probe, the file PROBEDEF.SYS will contain the basic probe settings. The dialog probe will also contain a POP setup file that the user can load from the dialog from the Welcome screen. The POP file will contain settings to configure:

- Wedge Settings
- Cycle Settings, including
 - Angle
 - Pulser and receiver delay values
 - Physical and Virtual Wedge Delay and Geometry Information as currently calculated
 - DGS Settings specific to the cycle
 - Near Field Length (N_{DGS}), in mm
 - Effective Diameter ($D_{straight}$), in mm
 - DGS Delay (DEL_{DGS}) used to shift the DGS diagram only, in mm.
 - Index Shift—the shift from the nominal angle part entry point along the X-axis (similar to the part entry point calculated by the DLC), in mm.
 - Transducer Width, in mm
 - Transducer Length, in mm
- Full Angle Range setup (ANGLE START, ANGLE STOP and ANGLE STEP).

A user cannot overwrite or delete the PROBEDEF.SYS file. After constructing this file with the probe part number, serial number and data, GE Inspection Technologies programs the dialog device with this file after probe validation.

The PROBEDEF.SYS contains the settings to configure the instrument for DGS for the first time. Once users define the instrument settings that work for the inspection, they can save the full instrument setup (POP) file back to the dialog probe.

The user may save additional setup “POP” files to the dialog probe if desired (and if there is enough free memory). In order to overwrite a POP file on the dialog probe, the user must first delete the file and then save the current settings as the file of the same name. Two values in the setup file indicate to the Phasor XS code that the PA DGS application should be implemented:

- PROBE TYPE: LF_DGS (linear flat DGS)
- APPLICATION TYPE: PLATE.

9.3 DGS Curve Interpolation

The user will select a beam (angle) to perform the reference recording. The DGS record mode then operates in a manner similar to conventional channel DGS recording.

Once the reference is recorded for the selected beam, when the user turns DGS on, the instrument will interpolate the curve for all beams. This interpolation is an internal calculation that the user cannot control except by deleting the curve and recording a new curve. Figure 81 below shows an example of two angle beam responses to backwall. The ΔV (delta V) value represents the gain difference between two beams at the given sound-path.

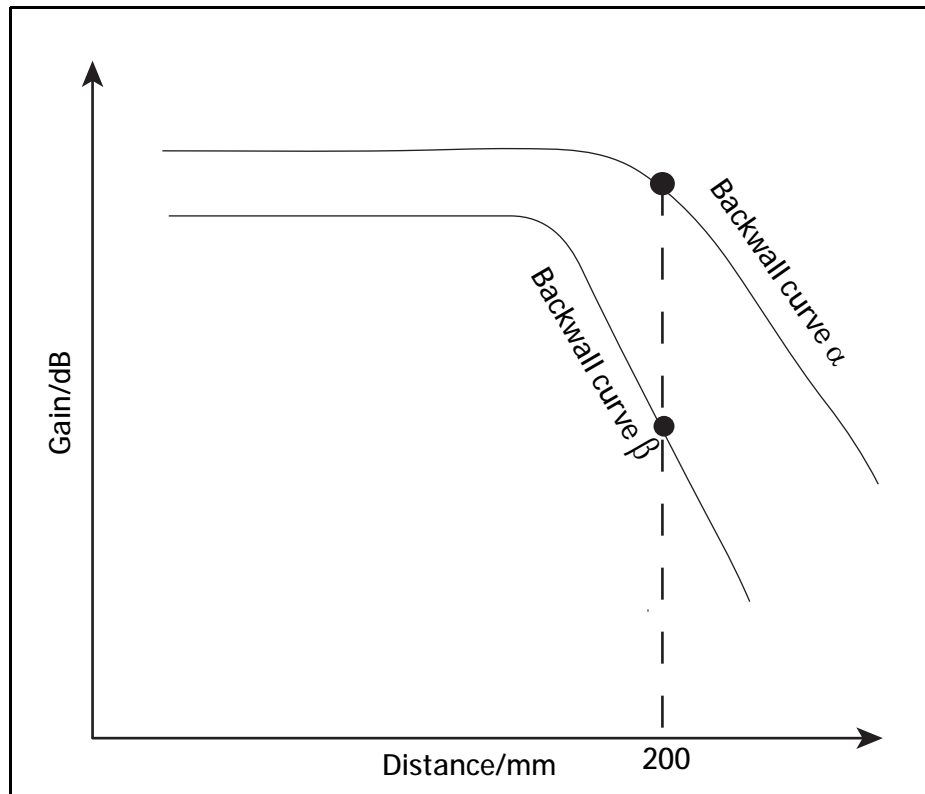

Figure 81: DGS Backwall Curves for Two Angles

9.3 DGS Curve Interpolation (cont.)

For any two angles, the difference between the two gain response values represents the ΔV for the beam response. The interpolation algorithm will provide a method to calculate the ΔV for each beam in the scan, given the user's specified reflector size and the recorded sound path.

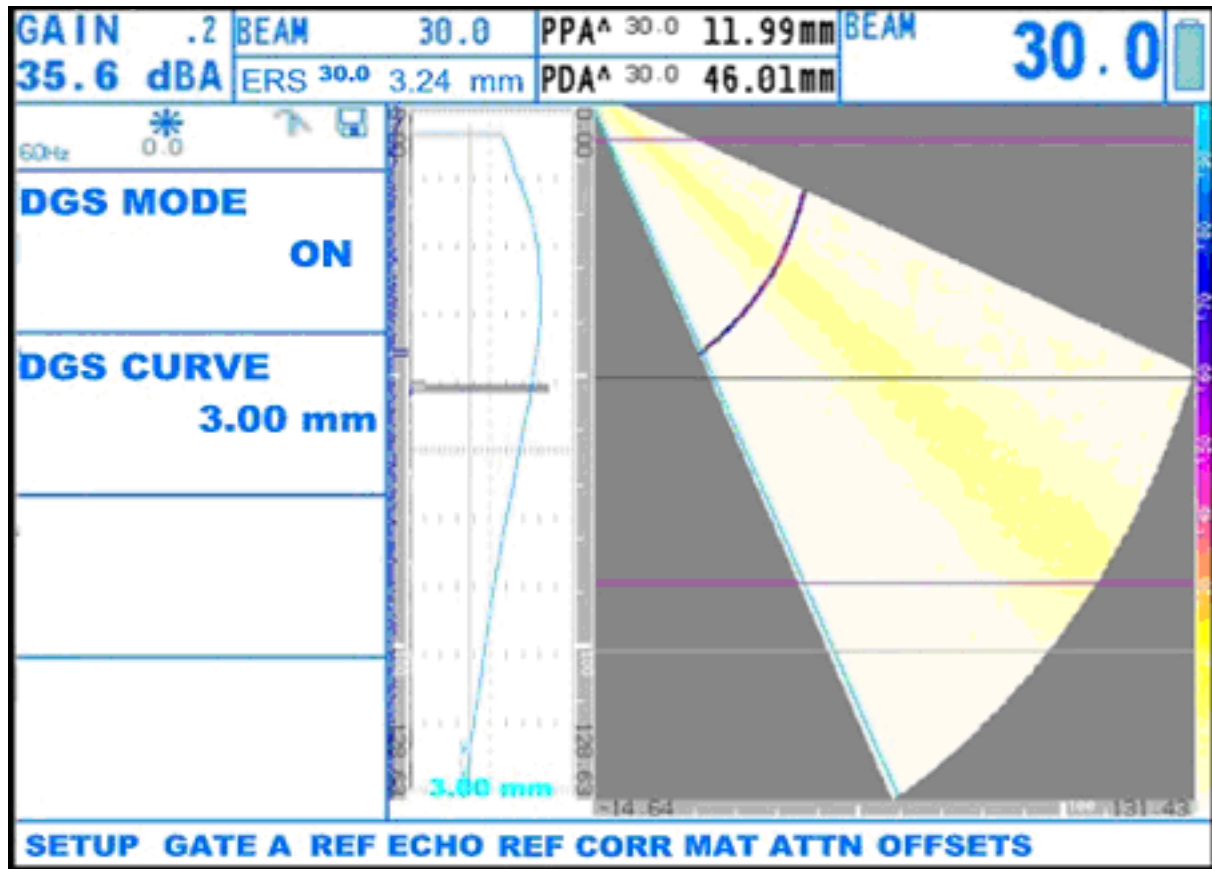

Figure 82: DGS Curve on Selected Beam

Changes to the gain will cause the curve(s) to be drawn at the corresponding level. As the beam cursor changes, the Phasor will draw the curve if the selected beam has a DGS curve calculated for it. If DGS references were not recorded on beams that bound the selected beam, no DGS curve was calculated and therefore no curve will be drawn.

Most codes require two to three legs. Draw the curve to the maximum sound path available on the screen. Use the 100xNF as in CV, and be aware of the end of instrument range. The DGS curve will only be drawn to the end of the second leg in time on the selected beam. The Phasor does not calculate/report DGS results when detected past the second leg.

9.4 Gain Control and Display

In typical use, the gain window resembles Figure 83 below, depending on the gain adjust mode selected.

Analog gain active	Digital gain active
GAIN .2	.1
14.2 dBA	1.8 dBD

Figure 83: Phasor XS Gain Window

For beams that have no DGS curve calculated, the gain window will appear shown in Figure 2 above.

While DGS is ON, the gain window display (shown in Figure 84 below) will be active when a beam is selected where a DGS curve has been calculated.

Analog gain active	Digital gain active
38.2dB -6.1dB	38.2dB -6.1dB
14.2 dBA .2	1.8 .1

Figure 84: Phasor XS Gain Window with DGS On

The font size will shrink to include the necessary information in the window. The gain displayed in upper-left position is total test gain (sum of digital and analog) that would put DGS curve peak to 80% SH for the selected beam.

Evaluation gain delta, in the upper-right position, is equal to the current total gain (digital and analog) — total test gain for the selected beam. When the Phasor XS applies transfer correction, the evaluation gain delta will be displayed in RED, or another contrasting color based on the color scheme, to draw attention to the fact that transfer correction is active. The presence of transfer correction limits gain controls.

9.5 Parameter Limit/Block

Table 3 below lists parameters that are locked or limited when there is no reference recorded, reference is recorded but DGS is OFF, and when DGS is ON.

Table 3: Parameter Limit and Block Table

Parameter ID	DGS OFF	DGS OFF	DGS ON
	NO REFERENCE	REFERENCE	REFERENCE
PAPID_DGS_REFTYPE		LOCK	LOCK
PAPID_DGS_REFSIZE		LOCK	LOCK
PAPID_MAT_THICKNESS		LOCK	LOCK
PAPID_PROBE_TYPE	LOCK	LOCK	LOCK
PAPID_PROBE_PART_NUM	LOCK	LOCK	LOCK
PAPID_PROBE_FREQUENCY	LOCK	LOCK	LOCK
PAPID_NUM_ELEMENTS	LOCK	LOCK	LOCK
PAPID_PROBE_PITCH	LOCK	LOCK	LOCK
PAPID_PROBE_ELEVATION	LOCK	LOCK	LOCK
PAPID_ELEMENT_1_POS	LOCK	LOCK	LOCK
PAPID_WEDGE_PART_NUM	LOCK	LOCK	LOCK
PAPID_WEDGE_VELOCITY	LOCK	LOCK	LOCK
PAPID_WEDGE_FRONT	LOCK	LOCK	LOCK
PAPID_WEDGE_OFFSET_Z	LOCK	LOCK	LOCK
PAPID_WEDGE_ANGLE	LOCK	LOCK	LOCK
PAPID_MATERIAL	LOCK	LOCK	LOCK
PAPID_SCAN_TYPE	LOCK	LOCK	LOCK
PAPID_FOCAL_POINT	LOCK	LOCK	LOCK
PAPID_WAVE_TYPE	LOCK	LOCK	LOCK
PAPID_ANGLE_START	LIMIT	LOCK	LOCK
PAPID_ANGLE_STOP	LIMIT	LOCK	LOCK
PAPID_ANGLE_STEP	LIMIT	LOCK	LOCK
PAPID_NUM_OF_STEPS	LOCK	LOCK	LOCK
PAPID_FIRST_ELEMENT	LOCK	LOCK	LOCK
PAPID_APERTURE_SIZE	LOCK	LOCK	LOCK
PAPID_APERTURE_STEP	LOCK	LOCK	LOCK
PAPID_PULSER_WIDTH		LOCK	LOCK
PAPID_PULSER_VOLTAGE		LOCK	LOCK
PAPID_RECEIVER_FREQ		LOCK	LOCK
PAPID_ASCAN_RECT		LOCK	LOCK
PAPID_GATE_TOF_MODE		LOCK	LOCK
PAPID_DGS_REF_ATTN	(lock for recorded beam)	LOCK	LOCK
PAPID_DGS_REF_AMPCORR	(lock for recorded beam)	LOCK	LOCK
PAPID_PROBE_DELAY		(LIMIT for calibrations)	LOCK
PAPID_MAT_VELOCITY_L	(LIMIT for calibrations)	(LIMIT for calibrations)	LOCK
PAPID_MAT_VELOCITY_S	(LIMIT for calibrations)	(LIMIT for calibrations)	LOCK
PAPID_CAL_VELOCITY	(LIMIT for calibrations)	(LIMIT for calibrations)	LOCK

9.5 Parameter Limit/Block (cont.)

A parameter that is locked, “(READ ONLY)” will appear in the third line of the parameter window. The sector scan angle range parameters will be limited to the range provided in the custom POP file.

- **ANGLE START:** The instrument will only allow ANGLE START to be changed to one of the angles in the range of angles of the custom POP file.
- **ANGLE STEP:**
The ANGLE STEP from the POP file is the smallest step increment that the user may set, and the value will change in multiples of this value. For example, if the step size of the POP file is 0.5 degrees, the will limit the step size to one of: 0.5, 1.0, 1.5, etc. In this example, the user will not have the ability to select an invalid step size (such as 0.8). The maximum step size will be (ANGLE STOP – ANGLE START).
- **ANGLE STOP:** The instrument will only allow ANGLE STOP to be changed to one of the angles in the range of angles of the custom POP file *and* will increment in multiples of ANGLE STEP, relative to ANGLE START. For example, if ANGLE START is 31.0 and ANGLE STEP is 10.0 and the current value of ANGLE STOP is 55.0.
 - A positive increment of ANGLE STOP will change ANGLE STOP to 61.0.
 - A negative increment of ANGLE STOP will change ANGLE STOP to 51.0.
- When the user performs a calculate, the instrument will:
 - Verify that the ANGLE START, ANGLE STOP and ANGLE STEP are valid. The instrument will display the message “INVALID ANGLE RANGE” and abort. This can happen if the user changes one of ANGLE START or ANGLE STEP parameters without changing ANGLE STOP to a valid range setting.
 - Copy (do not use the internal delay law calculator) the cycle information (element delays, etc.) for each angle in the user’s selected angle range to the cycle table.
 - Calculate the mapping table for the user’s selected angle range.

If an attempt to change a parameter listed as “LIMIT for calibration” a numeric limit will be applied with respect to the value of the parameter when the first reference was recorded for the scan. When a limit is reached the following error message will be displayed.

“LIMIT REACHED. DGS REFERENCE RECORDED.”

The parameters that have special limits once a DGS Reference is recorded are:

- Probe delay = ± 1.000 us from reference probe delay time
- Velocity = $\pm 5\%$ of the reference velocity

Disable the recalculate requirement, since these values will have negligible impact on the image, and the delay laws are fixed. This velocity change will have negligible impact on the delay laws.

9.6 DGS Evaluation Menus

With the DGS option for phased array, the DGS evaluation menu appears in the UT menu. Instead of the NRM/TCG and TCG EDIT menus, the DGS menu appears.

A new POP file setting, EVAL MODE, includes the following values:

- TCG—appears after reset or when the user loads a non-DGS file.
- DGS—available when DGS is enabled and user loaded a DGS file.

The evaluation mode parameter value will be saved and recalled with new POP files. When non-DGS dataset files are loaded, the evaluation mode will be set to TCG mode—whether EVAL MODE exists in the POP file or not. For example, version 2.25 POP files do not have the EVAL MODE parameter. If a version 2.25 POP file is loaded, the EVAL MODE parameter will be set to TCG. This parameter can be used internally, if necessary, to trigger or block certain functionality.

9.6.1 DGS Top Level Menu

When a user selects the DGS menu, the Phasor XS displays an entire submenu, shown below:

SETUP	GATE A	REF ECHO	REF CORR	MAT ATTN	OFFSETS	
-------	--------	----------	----------	----------	---------	--

These submenus and their parameters are explained in their individual sections.

9.6.1a DGS Setup Menu

In this menu, a user can turn on DGS, set the evaluation curve and change the beam cursor. The Setup menu contains three parameters: DGS Mode, DGS Curve and Beam Cursor.

The setup menu contains three parameters:

- DGS MODE
- DGS CURVE
- BEAM CURSOR

DGS Mode

The DGS mode parameter controls if the DGS mode is on or off. The parameter options are:

- OFF (default)
- ON

Users can turn DGS on *only* if valid references have been recorded and all plausibilities have been met. If the user attempts to turn DGS on without references, the following error message appears in the menu bar area:

“DGS CANNOT BE TURNED ON. DGS REFERENCES INCOMPLETE”

If another plausibility error occurs while calculating DGS curve information, the following message appears:

“DGS ERROR: {plausibility parameter} INVALID”, where the {plausibility parameter} indicates the cause of the error. The DGS mode can be turned off at any time. This parameter is stored and recalled with POP data files.

DGS Curve

The parameter specifies the circular disk-shaped equivalent reflector diameter used for displaying the DGS curve. This value is the threshold/reference for echo evaluations while DGS is on. It is displayed in the distance units active in the instrument (mm for metric or in for imperial).

Value range:

- Min 0.01 * the largest effective crystal diameter of the scan specified. (0.01 is the smallest normalized ERS in the DGS table)
- Max 1.0 * the smallest effective crystal diameter of the scan specified. (1.0 is the largest normalized ERS in the DGS table)
- Default 3.00 mm

Any time the DGS probe setting is changed, the value range must be checked and updated if its limits are exceeded. This value may be changed in any mode. If DGS is on the curve(s) drawn, the a-scan window will be updated. This parameter will be stored and recalled with a POP data file.

Beam Cursor

This is a repeat of the beam cursor control, so the user may adjust the selected beam without leaving the DGS menu. When the beam cursor is changed with DGS on, the ERS curve draw on the A-scan will be updated accordingly. The gain window will be updated accordingly when the beam cursor is changed and DGS is ON.

9.6.1b DGS Gate A Menu

This menu will repeat the Gate A Start, Width, Threshold and TOF mode for the PA channel. It will be independent of the selected gate controls currently implemented.

9.6.1c DGS Reference Echo Menu

This menu is where users can define the reference type and size and control the reference record and deletion. The Reference Echo menu contains three parameters.

- REFERENCE TYPE
- REF SIZE
- BEAM CURSOR
- RECORD/DELETE

Reference Type

This parameter defines the reference reflector type and specifies the reference type. The following options are available:

Choice	Description
BW (default)	Backwall
FBH	Flat-bottom Hole
SDH	Side-drilled Hole

This parameter cannot be changed once a reference has been recorded in the scan. All references in the scan must be deleted before the parameter can be changed. If the user attempts to change the parameter after a reference is recorded, the following message appears:

“FUNCTION BLOCKED - DGS REFERENCE HAS BEEN RECORDED.”

As the reference type is changed, the reference size parameter may need to be updated accordingly based on the minimum/maximum allowed reference sizes. This value is stored and recalled with POP files.

Reference Size

The reference size parameter defines the size of a FBH or SDH reflector. When a BW type reflector is specified, dashes are displayed (----) as the reference size.

This parameter cannot be changed once a reference has been recorded in the scan. All references in the scan must be deleted before the parameter can be changed. If the user attempts to change the parameter after a reference is recorded, the following message appears:

“FUNCTION BLOCKED - DGS REFERENCE HAS BEEN RECORDED.”

The parameter always displays dashes “----” when the BW reflector type is active. The user cannot change this setting. When the FBH or SDH reflector type is active, the size of the reflector is adjustable across the range of sizes:

- FBH: Minimum diameter: 0.3 X wavelength (λ) of probe frequency
- SDH: Minimum diameter: 1.5 X wavelength (λ) of probe frequency. The SP distance must be greater than 0.7 X NF length.

This parameter is stored and recalled with POP data files.

Beam Cursor

This parameter, a repeat of the beam cursor control found in other menus, offers additional functionality. When the beam cursor is changed, the status of the reference for the selected beam will be indicated under the “Record / Delete” parameter. The active beam indicates the beam that a reference can be recorded or deleted.

Record / Delete

This parameter will indicate the status of the DGS reference for the selected beam. It will be either:

- (NO REF), or
- (RECORDED)

If no reference is recorded, pressing this function will record the echo in the gate as the reference for the selected beam. If the echo TOF and amplitude detected do not meet certain criteria based on the reference type and size, the reference will not be recorded and an error message will be displayed. While DGS is ON, the software blocks recording and deletion operations. The following message appears:

“FUNCTION BLOCKED. DGS EVALUATION IS ON.”

If a reference is recorded, a quick press and release will display the following message for 3 seconds.

“REFERENCE WILL BE DELETED. PRESS HOME TO CONFIRM.”

If the user presses **Home** within three seconds, the reference on the current beam will be deleted. Any other key press will have no effect on the recorded reference.

If a reference is recorded, pressing and holding this function for 1 second will display the following message for 3 seconds.

“ALL REFERENCES WILL BE DELETED. PRESS HOME TO CONFIRM.”

If the user presses **Home** within three seconds, all recorded references in the scan will be deleted. Any other key press will have no effect on the recorded references.

All recorded references will be stored and recalled with POP data files, along with the velocity and probe delay at first reference record operation.

See the section on parameter limiting / blocking for details on the effect a recorded reference has on the remainder of the Phasor XS PA parameters.

9.6.2 DGS Reference Correction Menu

The reference correction menu contains parameters that allow for adjustments due to conditions of how the reference is recorded. The two parameters of this menu are:

- REF ATTEN
- AMPL CORRECT

9.6.2a Reference Attenuation

The reference attenuation parameter allows the user to specify the attenuation property of the reference reflector material. The units are dB/m when in metric units or dB/in when in imperial units. The value range is 0 - 100.0 dB/m with 0.1 dB/m steps.

If the user attempts to change this parameter after a reference has been recorded, the following error message will be displayed:

“FUNCTION BLOCKED - DGS REFERENCE HAS BEEN RECORDED.”

The default value is 0.0 dB/m. This parameter applies to all references recorded on the scan.

9.6.2b Amplitude Correction

This parameter allows users to apply a correction to the amplitude of the reference echo during the record process. The units are in dB. The range of the value is -20.0 to +20.0 dB in 0.2 dB steps.

If the user attempts to change this parameter after a reference has been recorded, the following error message will be displayed:

“FUNCTION BLOCKED - DGS REFERENCE HAS BEEN RECORDED.”

Default value 0.0 db.

This parameter applies to all references recorded on the scan.

9.6.3 DGS Material Attenuation Menu

The material attenuation menu allows the user to specify corrections that apply to the test material.

The two parameters of this menu are:

- TEST ATTEN
- dBA TRANS CORR

Test Attenuation

This parameter specifies the attenuation of the test material in dB/m or db/in. The range extends from 0.0 to 100.0 dB/m in 0.1 dB steps. This parameter may be changed at any time, and will recalculate the DGS curve displayed in order to consider the influence of the material's attenuation. The default value is 0.0 dB/m.

Transfer Correction

This parameter allows for corrections to the gain to compensate for coupling conditions and other factors that effect gain in the test material. The dynamic range of the amplifier and the current gain value of the instrument limit the range of the analog gain values. Resolution is in 0.2 dB steps. This parameter may be changed at any time, and will change the instrument's gain correspondingly, but keeps the position of the DGS curve unchanged. The default value is 0.0 dB.

When transfer correction is not 0.0 dB, the “T” version of the DGS icon will be displayed in the icon line and its color will contrast against the background. (See “DGS Icon” on page 188.).

DGS Offsets Menu

Offset curves will be drawn only in the A-Scan view mode. The offset curve will be drawn only on the A-scan window, offset from the active DGS reference curve.

The Offsets menu allows the user to turn off and on and set the value of offset lines from the reference curve. The four parameters of this menu are:

- OFFSET 1
- OFFSET 2
- OFFSET 3
- OFFSET 4

You can use the knob to change each offset's value across the supported range. The value of 0.0 is displayed as OFF. To set the offset value to OFF, press and hold the parameter select button for 3 seconds.

When the offset value is on, a numeric gain value is displayed in signed dB units. The user may change the gain value across the range of -24.0 dB to +24.0 dB in 0.5 dB steps. The default value for all offsets is OFF.

9.7 DGS Icon

When a DGS reference exists on the scan, the DGS icon  (same as conventional channel) will be displayed in the ICON line in the same position as the TCG icon would appear. The icon is displayed independent of the state of the DSG mode setting, on or off.

When transfer correction is present, the icon will change appearance to include the letter “T” (same as conventional channel) and the color will be RED or another contrasting color, depending on the color scheme, to highlight that transfer correction is applied in evaluation.

9.8 PA Results

The following results will be added to the existing list when DGS is operating in phased array mode:

- LA Selected Beam Gate A echo detected - LEG number
- LB Selected Beam Gate B echo detected - LEG number
- DBrA Selected Beam Gate A echo - dB to reference result
- DBrB Selected Beam Gate B echo - dB to reference result
- A%rA Selected Beam Gate A echo - % of reference result (-6dB = 50%, +6dB = 200%)
- A%rB Selected Beam Gate B echo - % of reference result (-6dB = 50%, +6dB = 200%)
- ERSB Selected beam Gate B ERS

Any time that results are invalid due to a plausibility limitation or limits applied to input data, dashes will appear as the result (as they would with conventional channel).

9.9 JPEG Reports

When the evaluation mode is set to DGS, the following parameter section will be part of the PA JPEG reports when parameters are included in the report.

DGS	DGS MODE	DGS CURVE	MIN EFF DIAM	
	REF SIZE	REF ATTEN	AMPL CORRECT	NUM OF REFS
	TEST ATTEN	TRANSFER CORR		
	OFFSET 1	OFFSET 2	OFFSET 3	OFFSET 4

The NUM OF REFS will indicate the number of beams for which reference points are recorded. The "Min Eff Diam" is the smallest effective diameter of all of the beams in the scan. All other parameters are reported from their respective user interface parameter.

9.10 Validation

Validating the performance requires the use of a signal generator and step attenuators to more accurately induce a signal at a given sound path and amplitude. Using the DGS curve data, construct an Excel spreadsheet to calculate the necessary setup information for each probe:

1. For each reference recorded (each of 1 x NF, 5 x NF and 10 x NF), verify the signal at each sound path distance in the table for amplitude:
 - On the curve
 - 6dB below the curve
 - 6dB above the curve

Then verify the signal at three locations between points in the DGS table for amplitude:

- On the curve
- 6 dB below the curve
- 6 dB above the curve

The full validation plan must include verification of error messages for references that are taken at the wrong sound path distances.

9.11 Data Storage and Recall

All non-calculated fields and not-fixed-table data of the DGS system will be stored and recalled with POP dataset files. This includes, but is not limited to:

- Reference TOF, Amplitude and gain on each beam a reference was recorded
- Probe Delay and velocity when first reference was recorded
- Reference size
- Reference amplitude correction
- Reference attenuation
- Transfer corrections (dBD and dBA)

[no content intended for this page - proceed to next page]

Appendix A. Technical Specifications

A.1 Physical Specifications

On-Board Memory	Set-Up Files
Transportable Memory	On SD Card for report and set-up files
Documentation Format	JPEG
Weight	3.8 kg (8.2 lbs) with battery
Dimensions	282 mm W x 171 mm H x 159 mm D (11.1 in. W x 6.8 in. H x 6.3 in. D)
Battery	Custom Li Ion Battery Pack -356P configuration
Battery life	6 hrs. minimum
Battery Charging	External charger
External Power Supply	Universal Input 85 to 260 V/50 to 60 Hz
Probe Connectors	Conventional - 00 lemo/BNC adapters provided - Phased Array - Custom ZIF
VGA Output	Yes
Dialog Languages	Chinese, English, French, German, Japanese, Spanish, Polish, Romanian, Russian, and Czechoslovakian
Display Size	165 mm (6.5 in.) diagonal
Display Resolution	VGA color TFT 640H x 480V pixel
Internal Capacity	Capacity: 127 kB Maximum Number of Dataset Files: 24 (combined phased array and conventional)
SD Card Specification	File System Format: FAT16 Maximum Capacity: 1.0 GB WARNING: The Phasor XS can not read/write to SD cards of greater than 1.0 GB.

A.2 Phased Array/Conventional Channel Specifications

Feature	Conventional	Phased Array
Pulser	Spike	Bi-Polar Square Wave
Pulse Repetition Frequency	15 to 2000 Hz	≤100V: 20 to 7000 Hz >100V: 20 to 2800 Hz
Pulser Voltage	300 V max ±	25 V to ± 75 V (bi-polar)
Pulser Energy	Low/High	
Pulser Rise Time	< 15 nsec	< 15 nsec
Damping	50 and 1000 ohms	
Dual Mode	Off/On	
Receiver Input Capacitance	< 50 pF	
Receiver Input Resistance	1000 ohms in dual mode	220 ohms
Maximum Input Voltage	40 V peak-to-peak	200 mV peak-to-peak
Bandwidth/Amplifier Band-aids	0.3 to 15 MHz @ -3dB	0.6 - 6.5 MHz
Filter Selection	1.0, 2.0, 2.25, 4.0, 5.0, 10 and 13 MHz + BB	2.0, 3.0, 4.0, 5.0 MHz, Low Pass 4 MHz, High Pass 5 MHz and Broadband (0.6 to 6.5 MHz)
Rectification	Pos HW, Neg HW, FW, and RF	Pos HW, Neg HW, FW, and RF
Analog Gain	0 to 110 dB	0 to 40 dB
Max. Digital Gain		0 to 50 dB Custom: 15.8 to 39.9 dB (depending on aperture size)
Focal Laws		User selectable - 128 max
Physical Probe		1 to 64
Virtual Probe		1 to 16
Number of Cycles		1 to 128
Pulser Width @ 1/2 Cycle		40 to 500 nsec
Pulser Delay		0 to 10.24 μsec
Receiver Delay		0 to 10.24 μsec
Acoustic Velocity	1000 to 16000 m/s 0.0393 to 0.6299 in./μsec	1000 to 15000 m/s 0.0393 to 0.5905 in./μsec
Measurement Range	14 m @ 5900 m/s	1.8 m @ 5900 m/s
Display Delay	10 m @ 5900 m/s	1.8 m @ 5900 m/s

Auto Timebase Calibration	Yes	
Feature	Conventional	Phased Array
Reject	0 to 80%	
TCG	15 points @ 6 dB/?-sec	16 points @ 6 dB/ μ sec
Gates	A and B	A, B and IF
Gate Threshold	5 to 95%	5 to 95%
Gate Start	0 mm to full range	0.1 mm to 1 m
Gate Width	1 mm to full range	0.1 mm to 1 m
Gate Modes	Off, Positive, and Negative Off, Coincidence, and Anticoincidence	Off, Positive, and Negative Off, Coincidence, and Anticoincidence
TOF Modes	Flank/Peak/JFlank	Flank/Peak
Scan Type		Linear and Sector
Available Views	A-Scan	A-Scan, Image, and Both
Displayed Readings	Amplitude, Sound Path, and Trig	Amplitude, Sound Path, Trig, and Peak Mode
Measurement Resolution	5 nsec	5 nsec
Displayed Units of Measurement	mm and inch	mm and inch

A.3 Environmental Tests

Per Mil-Std-810F	
Cold Storage	-20°C for 72 hrs, 502.4 Procedure I
Cold Operation	0°C for 16 hrs, 502.4 Procedure II
Heat Storage	+70°C for 48 hrs, 501.4 Procedure I
Heat Operation	+50°C for 16 hrs, 501.4 Procedure II
Damp Heat / Humidity (storage)	10 Cycles: 10hrs at +65°C down to +30°C, 10 hrs at +30°C up to +65°C, Transition within 2 hrs, 507.4
Temperature Shock	3 Cycles: 4 hrs at -20°C up to +70°C, 4 hrs at +70°C, Transitions within 5 mins. 503.4 Procedure II
Vibration	514.5-5 Procedure I, Annex C, Figure 6, General exposure: 1hr each axis
Shock	6 cycles each axis, 15g, 11ms half sine, 516.5 Procedure I
Loose Cargo	514.5 Procedure II
Transit Drop (for shipment)	516.5 Procedure IV, 26 drops
IP54 / IEC529 ... Dust Proof / dripping water proof as per IEC 529 specifications for IP54 classification	

A.4 Phased Array Probes

Product Code	Frequency MHz	Element							Cable Length	
		Count	Aperture		Elevation		Pitch		m	ft
			mm ²	inch ²	mm	inch	mm	inch		
L8U84	2	8	8 x 9	.31 x .35	9	.35	1	.039	2	6.5
L8U96	4	16	8 x 9	.31 x .35	9	.35	0.5	.020	2	6.5
EUN75	5	32	16 x 10	.63 x .39	10	.39	0.5	.020	2	6.5
L99HK	5	16	16 x 10	.63 x .39	10	.39	1	.039	2	6.5
L99KO	2.25	16	16 x 13	.63 x .51	13	.51	1	.039	2	6.5
L99LQ	2.25	16	24 x 19	.94 x .75	19	.75	1.5	.059	2	6.5
L99JM	5	32	32 x 10	.2.5 x .39	10	.39	1	.039	2	6.5

GE Inspection Technologies: productivity through inspection solutions. GE Inspection Technologies provides technology-driven inspection solutions that deliver productivity, quality and safety. We design, manufacture and service Ultrasonic, Remote Visual, Radiographic and Eddy Current equipment and systems, offering specialized solutions that will help you improve productivity in your applications in the Aerospace, Power Generation, Oil & Gas, Automotive or Metals Industry. Contact your GE Inspection Technologies representative or visit www.ge.com/inspectiontechnologies for more information.

A.5 RS-232 Serial Port Connector

The serial port of a PC can connect with the instrument via the RS-232 serial port located at the upper-rear corner of the instrument shown in Figure 85.

You must connect the instrument to the PC using a seven-pin LEMO to PC serial cable. The serial port connector pin assignments are shown in Figure 86 on the next page.

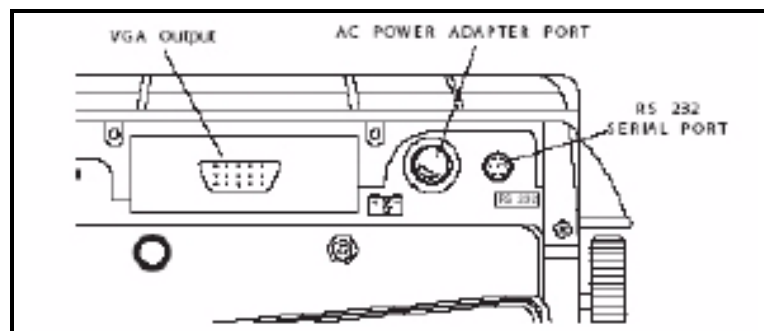

Figure 85: Serial Port Connector Location

A.5 RS-232 Serial Port Connector (cont.)

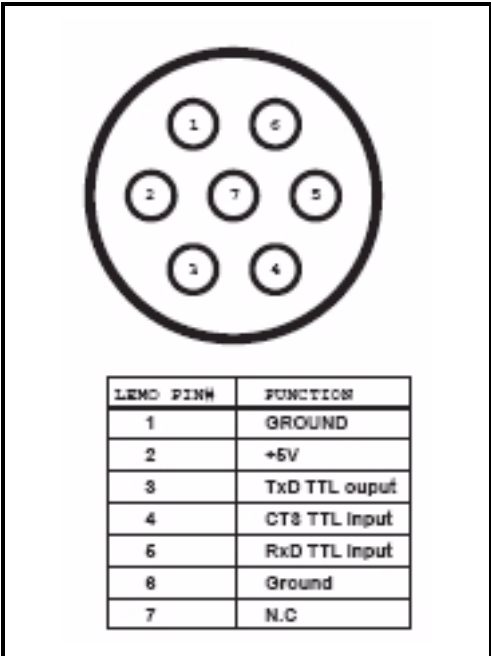

Figure 86: Serial Port Connector

A.6 SAP/TTL Output Connector

The output control connector is a seven-pin LEMO connector located on the side of the instrument (above the Right Function Knob shown in Figure 87 below). This connector can be used to:

- Monitor the TTL Alarm output
- Monitor Beam SAP or scan SAP
- Connect a 5-volt bidirectional encoder

The connector's pin assignments are shown in Figure 88 below.

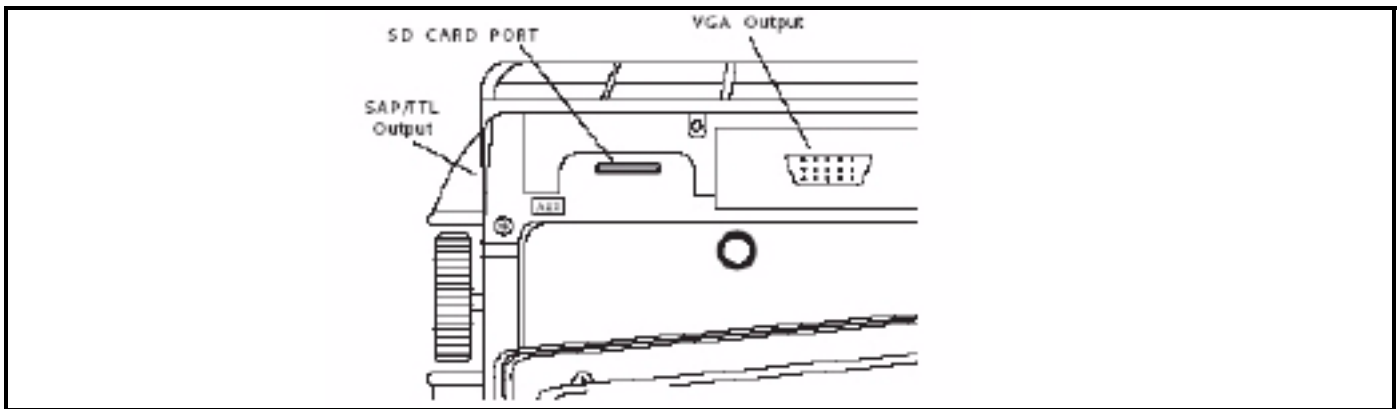

Figure 87: Output Control Connector Location

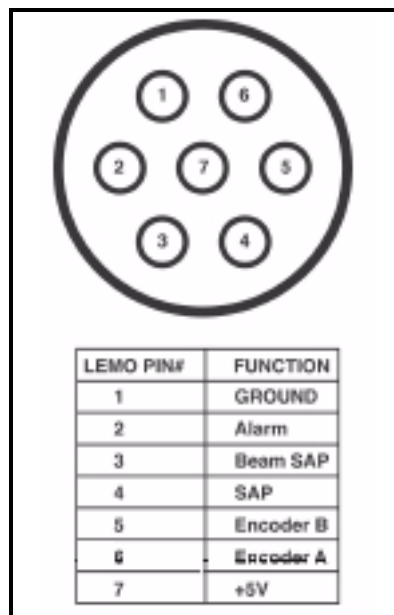

Figure 88: Output Control Connector

Numerics		
1.....	3, 57, 64, 97, 114, 125	
1, CURSOR	63	
2, CURSOR	63	
A		
A Gate	108	
A%A	55, 57, 114	
A%B	56, 114	
A%I	56	
ACTION.....	138	
activation code	105	
alarm	104	
Alarms	111	
AMP COLOR PALET	20	
AMP COLOR PALETTE.....	148	
AMPL CORRECT	127, 128	
ANGLE	25	
Angle Beam Probes	112	
ANGLE START	32	
ANGULAR CORRECTED VIEW	32	
APERATURE	32	
AS AQUIRED	157	
A-Scan (Conventional)	102	
ASCAN COLOR.....	96	
A-SCAN MODE.....	62	
A-Scan Range	102	
A-Scan REJECT Level	101	
AUTO 80	127, 133	
AUTOCAL.....	104	
AWS D1.1 / D1.5	131	
axes	54	
B		
BACKGROUND.....	20	
battery pack	2	
BEAM	56	
BEAM CURSOR	73, 74	
Beam Cursor.....	55	
BEAM GROUP.....	71	
Beam Ultrasonic Depth	62	
B-Gate	108	
BIP.....	112	
BOLD LINE.....	135	
BRIGHTNESS	20, 95	
buffer	145	
C		
CALALARM Submenu	104	
CALIBRAT.....	43	
Calibrating	103	
CLEAR	158	
CLOCK	147	
CLS	135	
CODE Submenu	105	
COLOR	20, 95	
COLOR ASCAN.....	20	
COLOR LEG	33, 113	
CONFIG Submenu	83	
Conventional operation Home Menu.....	82	
conventional probe	97	
conventional ultrasonic mode.....	77	
CURSOR 1.....	63, 157	
CURSOR 2.....	63	
CYC GAIN CNTL	71	
cyclic gain control.....	71	
D		
DA.....	56	
DA^	55	
DAC.....	119	
DAC Curve.....	119, 120, 133, 134	
DAC TYPE.....	119	
DAMPING	98	
Data Set Files	137, 138, 139	
DATA SOURCE	148	
DATE.....	19, 94	
DATE FORMAT	18, 94	
dB REF.	66, 130	
dB STEP.....	117	
DB^	56	
DB/	56	
dBA (analog gain).....	66	
dBD (digital gain)	66	
DELAY VELOCITY.....	125	
DELETE CURVE	74	

DGS	124	GATE POS	39
DGS Reference Curve	125	GATE SELECT	40
DIALOG PROBE	138	GATE START	40, 109
DISPLAY	20, 95	GATE THRESHOLD	40, 109
DISPLAY DELAY	33, 102	GATE WIDTH	40, 109
DISPLAY LENGTH	147, 149, 150	Gate-Alarm Logic	111
display screen	13	GATEMODE	39
DISPLAY START	34	GATES	108
DISPLAY-COLOR	95	Gates Menu	108
DISPLAY-GRID	95	Gr.	129
Distance Gain Sizing	124		
DUAL	97		
		H	
E		H Line	134
EFF. DIAMETER	125	HDR IN REPORT	142
ELEM 1 POS	26	HEADER	142
ENCODER	150	HIGH END	26
encoder	149	Home Key	3, 79
ENERGY	101		
environmental compliance	203	I	
		Icons	92
F		IF Gate	40
FBH	129	IF START	34
FILENAME	139, 157	IMAGE	20
FILES Menu	137	INCH	95
FLANK	41, 110	INT MEMORY	138
FOCAL POINT	30	IP START	34
FRAME	146		
Freeze Key	3, 79	J	
Freeze Menu	63	JFLANK	110
Freeze Mode (Phased Array)	63, 64, 65	JIS Class	135
FREQUENCY	24, 37, 98	JISDAC	133
FULLWAVE	37, 100		
Function Rotary Knob	3, 79	K	
		Knob	3
G		Knob Emulator Key	3, 79
Gain	117		
Gain (Phased Array)	66	L	
Gain Increment Key	3, 79	L Line	134
Gain Rotary Knob	79, 116	LANGUAGE	18, 94
Gain Step	117	LARGE	115
GATE DISPLAY	40	large reading box	115
Gate Magnify Key	79	LEG	33
		LINEAR SCAN TYPE	30
		Lithium battery pack	1

READING	61	SDH	126
READING 5/LRG	115	SECTOR SCAN TYPE	30
reading boxes	115	SERIAL NUMBER	23
Recall	139	serial number	105
RECEIVER	97, 100	SOURCE/DEST	138
Receiver	36	SPLIT	115
receiver frequency	37	S-REF1	104
RECEIVER-FREQUENCY	98	S-REF2	104
Rectification	37	START	158
Rectification Mode	100	STARTUP	18, 93
RECTIFY	37, 38, 100	STEP	32
recycling	203	STOP	158
REF ATTEN	127	STORE DATASET	138, 139
REF CORR	127	submenus	4
REF ECHO	127	SYNCH	34
Reference Echo	125		
REFERENCE TYPE	127	T	
REGIONAL	18, 94	TCG	121
REJECT	101	TCG EDIT	73
REMINDER	104	TCG Mode (Phased Array)	68
Report	142, 143	TCG ReferencePoints	121
Report Header	142	TEST ATTEN	128
RESULTS	114	THICKNESS	113
RESULTS1	61	THRESHOLD	40
RESULTS2	115	TIME	19, 94
RESUME	158	Time Formats	18, 94
Return Policy	205	TIMED	147
RF	37	TOF COLOR PALETTE	148
RS-232	194	TOF MODE	41, 110
S		TOP View	145
s	115	TOP View Control Menu	152
SA	56	TRANSFER CORR	128
SA^	55	transverse acoustic velocities	29
SAMPLE INTERVL	150	TRIG	113
SAMPLE INTRVL	147	TRIG Menu	112
SAVE EDITS	116, 139	TTL #1	43
SB^	56	TTL OUT	111
SB/.	56	TTL Outputs	111
SBA	56	U	
scan parameters	30	UNFOCUSED	30
SCAN PATTERN	32	UNITS	18
SD CARD	138	Units of Measurement	95

USER GAIN	117
USER GAIN STEP	117
UT Menu	39

V

VELOCITY	25
VELOCITY L	29
VELOCITY T	29
VIDEO REVERSE	20
View (Phased Array)	53
VIEW MODE	146
View Select Key	3, 79
VIEW WINDOW	157
VOLTAGE	36
voltage	101

W

Warranty	205
WDGE DAT	24
WDGE GEO	25
wedge angle	25
WEDGE FRONT	25
WIDTH	40

X

X VALUE	113
XTAL FREQUENCY	125

Z

ZA	56
ZA^	55
ZB^	56
ZB/	56

[no content intended for this page - proceed to next page]

Environmental Compliance



The equipment that you bought has required the extraction and use of natural resources for its production. It may contain hazardous substances that could impact health and the environment.

In order to avoid the dissemination of those substances in our environment and to diminish the pressure on the natural resources, we encourage you to use the appropriate take-back systems. Those systems will reuse or recycle most of the materials of your end-life equipment in a sound way.

The cross-out wheeled bin symbol invites you to use those systems.

If you need more information on the collection, reuse, and recycling systems, please contact your local or regional waste administration.

Visit www.ge.com/inspectiontechnologies for take-back instructions and more information about this initiative.



EU Battery Directive

This product contains a battery that cannot be disposed of as unsorted municipal waste in the European Union. See the product documentation for specific battery information. The battery is marked with this symbol, which may include lettering to indicate cadmium (Cd), lead (Pb), or mercury (Hg). For proper recycling return the battery to your supplier or to a designated collection point.

What do the markings mean?

Batteries and accumulators must be marked (either on the battery or accumulator or on its packaging, depending on size) with the separate collection symbol. In addition, the marking must include the chemical symbols of specific levels of toxic metals as follows:

Cadmium (Cd) over 0.002%

Lead (Pb) over 0.004%

Mercury (Hg) over 0.0005%

The risks and your role in reducing them

Your participation is an important part of the effort to minimize the impact of batteries and accumulators on the environment and on human health. For proper recycling you can return this product or the batteries or accumulators it contains to your supplier or to a designated collection point. Some batteries or accumulators contain toxic metals that pose serious risks to human health and to the environment. When required, the product marking includes chemical symbols that indicate the presence toxic metals: Pb for lead, Hg for mercury, and Cd for cadmium. Cadmium poisoning can result in cancer of the lungs and prostate gland. Chronic effects include kidney damage, pulmonary emphysema, and bone diseases such as osteomalacia and osteoporosis. Cadmium may also cause anemia, discoloration of the teeth, and loss of smell (anosmia). Lead is poisonous in all forms. It accumulates in the body, so each exposure is significant. Ingestion and inhalation of lead can cause severe damage to human health. Risks include brain damage, convulsions, malnutrition, and sterility. Mercury creates hazardous vapors at room temperature. Exposure to high concentrations of mercury vapor can cause a variety of severe symptoms. Risks include chronic inflammation of mouth and gums, personality change, nervousness, fever, and rashes.

Visit www.ge.com/inspectiontechnologies for take-back instructions and more information about this initiative.

Warranty

Each instrument manufactured by GE Sensing is warranted to be free from defects in material and workmanship. Liability under this warranty is limited to restoring the instrument to normal operation or replacing the instrument, at the sole discretion of GE Sensing. Fuses and batteries are specifically excluded from any liability. This warranty is effective from the date of delivery to the original purchaser. If GE Sensing determines that the equipment was defective, the warranty period is:

- one year from delivery for electronic or mechanical failures
- one year from delivery for sensor shelf life

If GE Sensing determines that the equipment was damaged by misuse, improper installation, the use of unauthorized replacement parts, or operating conditions outside the guidelines specified by GE Sensing, the repairs are not covered under this warranty.

The warranties set forth herein are exclusive and are in lieu of all other warranties whether statutory, express or implied (including warranties or merchantability and fitness for a particular purpose, and warranties arising from course of dealing or usage or trade).

Return Policy

If a GE Sensing instrument malfunctions within the warranty period, the following procedure must be completed:

1. Notify GE Sensing, giving full details of the problem, and provide the model number and serial number of the instrument. If the nature of the problem indicates the need for factory service, GE Sensing will issue a RETURN AUTHORIZATION NUMBER (RAN), and shipping instructions for the return of the instrument to a service center will be provided.
2. If GE Sensing instructs you to send your instrument to a service center, it must be shipped prepaid to the authorized repair station indicated in the shipping instructions.
3. Upon receipt, GE Sensing will evaluate the instrument to determine the cause of the malfunction.

Then, one of the following courses of action will then be taken:

- If the damage is covered under the terms of the warranty, the instrument will be repaired at no cost to the owner and returned.
- If GE Sensing determines that the damage is not covered under the terms of the warranty, or if the warranty has expired, an estimate for the cost of the repairs at standard rates will be provided. Upon receipt of the owner's approval to proceed, the instrument will be repaired and returned.

[no content intended for this page - proceed to next page]

Customer Support Centers

North/South America

50 Industrial Park Road
Lewistown, PA 17044
U.S.A.
Tel: 866 243 2638 (toll-free)
717 242 0327

Germany

Robert Bosch Str.
50354 Hürth
Germany
Tel: +49 2233 601 0

United Kingdom/Ireland

892 Charter Avenue Canley
Coventry CV4 8AF
England
Tel: +44 845 130 3925

France

68, Chemin des Ormeaux
Limonest 69760
France
Tel: +33 47 217 9216

E-mail: geit-info@ge.com

Spain

San Maximo,31, Planta 4A, Nave 6
Madrid 28041
Spain
Tel: +34 195 005 990

China

5F, Building 1, No. 1 Huatuo Road,
Zhangjiang High-Tech Park
Shanghai 201203
China
Tel: +86 800 915 9966 (toll-free)
+86 (0)21-3877 7888

Japan

7F Medie Corp Bldg. 8
2-4-14-Kichijoji Honcho,
Musashino-shi
Tokyo 180-0004
Japan
Tel: +81 442 67 7067

www.geinspectiontechnologies.com

ISO 9001
REGISTERED COMPANY

©2010 General Electric Company. All rights reserved.
Technical content subject to change without notice.